



HANSA-TMP

MANUFACTURING YOUR SUCCESS

HT 79 / B / 102 / 0621 / IE

Flange SAE

SAE Flanges



INDICE / CONTENTS

Flange SAE filettate GAS - BSP threaded SAE flanges	4
Flange SAE filettate NPT - NPT threaded SAE flanges	5
Flange SAE a saldare di tasca - Weld in SAE flanges	6
Flange SAE a saldare di testa - Weld on SAE flanges	7
Controflangia SAE filettata GAS - BSP threaded SAE counterflanges	8
Controflangia SAE a saldare di tasca - Weld in SAE counterflanges	9
Controflangia SAE a saldare di testa - Weld on SAE counterflanges	10
Flange doppie SAE filettate GAS - BSP threaded double SAE flanges	11
Flange doppie a saldare di tasca - Weld in double flanges	12
Flange doppie a saldare di testa - Weld on double flanges	13
Flangia cieca - Blind flanges	14
Flange SAE filettate GAS 90° - 90° BSP threaded SAE flanges	15
Flange SAE filettate NPT 90° - 90° NPT threaded SAE flanges	16
Flange SAE a saldare di tasca a 90° - 90° weld in SAE flanges	17
Flange SAE a saldare di testa a 90° - 90° weld on SAE flanges	18
Semiflangia SAE intera - Uncut SAE split flanges	19
Semiflangia SAE intera con fori filettati metrici Uncut SAE split flanges with metric threaded fixing holes	20
Semiflangia SAE tagliata - SAE split flanges	21
Coduli SAE a saldare di testa - Weld on SAE adaptors	22
Flangia SAE 90° - L BLOCK - SAE 90° - L BLOCK flanges	23
Flangia SAE riduzione 90° - 90° SAE reduction BLOCKS	24
Flangia SAE - T BLOCK - SAE - T BLOCK flanges	25

Flange SAE filettate GAS
BSP threaded SAE flanges

Materiale: Acciaio
Material: Steel

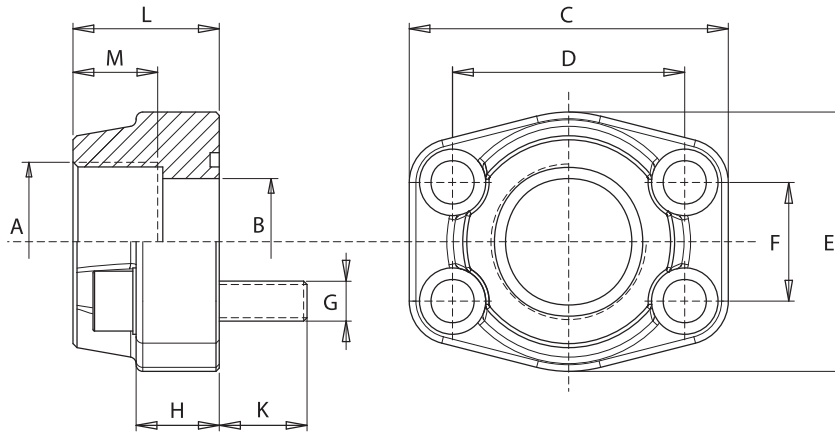

3000 psi

PRESS. MAX bar	TIPO TYPE	A SAE	B	L	H	M	K	C	D	E	F	G		O-Rings
												Viti/Screws Metr.	UNC	
345	F080G038	3/8"	13	36	16	13	14	58	38,10	48	17,48	M8	5/16"	4075
345	F080G012	1/2"	13	36	16	15	14	58	38,10	48	17,48	M8	5/16"	4075
345	F100G034	3/4"	19	36	18	18	16	67	47,63	50	22,23	M10	3/8"	4100
345	F102G100	1"	25	38	18	20	16	72	52,37	54	26,19	M10	3/8"	4131
275	F104G114	1 1/4"	31	41	21	22	18	81	58,72	70	30,18	M10	7/16"	4150
200	F106G112	1 1/2"	38	44	25	24	18	95	69,85	78	35,71	M12	1/2"	4187
200	F108G200	2"	50	45	25	26	18	104	77,77	90	42,88	M12	1/2"	4225
170	F110G212	2 1/2"	63	50	25	30	18	116	88,90	102	50,80	M12	1/2"	4275
135	F112G300	3"	73	50	27	30	25	136	106,38	125	61,93	M16	5/8"	4337
35	F114G312	3 1/2"	89	50	27	30	25	153	120,65	137	69,85	M16	5/8"	4387
35	F116G400	4"	99	50	27	30	25	163	130,18	147	77,77	M16	5/8"	4437
35	F118G500	5"	120	50	28	30	25	185	152,40	181	92,08	M16	5/8"	4537

6000 psi

PRESS. MAX bar	TIPO TYPE	A SAE	B	L	H	M	K	C	D	E	F	G		O-Rings
												Viti/Screws Metr.	UNC	
420	F401G038	3/8"	13	36	16	13	14	58	40,49	48	18,24	M8	5/16"	4075
420	F401G012	1/2"	13	36	16	15	14	58	40,49	48	18,24	M8	5/16"	4075
420	F402G034	3/4"	19	36	19	18	16	72	50,80	54	23,80	M10	3/8"	4100
420	F403G100	1"	25	44	24	20	19	81	57,15	70	27,76	M12	7/16"	4131
420	F404G114	1 1/4"	31	44	27	22	22	95	66,68	78	31,75	M14	1/2"	4150
420	F405G112	1 1/2"	38	51	30	24	24	107	79,38	90	36,50	M16	5/8"	4187
420	F406G200	2"	50	70	37	33	32	136	96,82	117	44,45	M20	3/4"	4225
420	F408G212	2 1/2"	63	75	45	35	40	167	123,80	151	58,70	M24	-	4275
420	F410G300	3"	73	90	55	40	55	209	152,40	179	71,40	M30	-	4337

Esempio codice di ordinazione - Ordering example

F404 G114 -
Flangia
Flange

Su richiesta: - On request:
M Viti metriche, rondelle, O-Rings
Metrical screws, washers, O-Rings
U Viti UNC, rondelle, O-Rings
UNC screws, washers, O-Rings
(brunite - burnished)

Flange SAE filettate NPT
NPT threaded SAE flanges

Materiale: Acciaio
Material: Steel

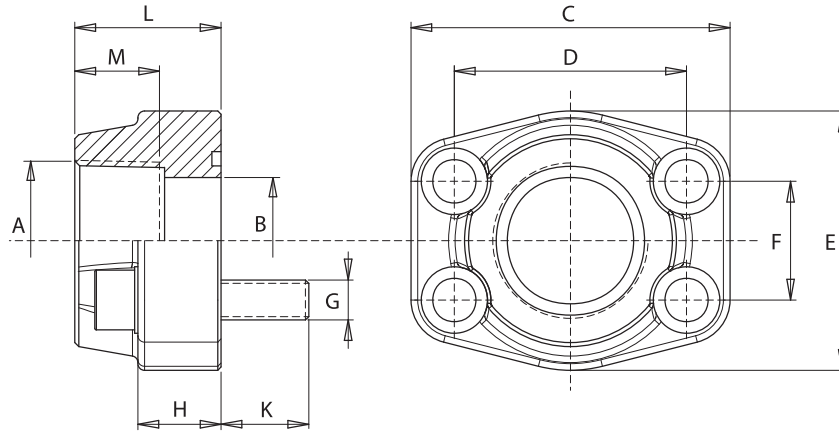

3000 psi

PRESS. MAX bar	TIPO TYPE	A SAE	B	L	H	M	K	C	D	E	F	G Viti/Screws		O-Rings
												Metr.	UNC	
345	F080N038	3/8"	13	36	16	19	14	58	38,10	48	17,48	M8	5/16"	4075
345	F080N012	1/2"	13	36	16	19	14	58	38,10	48	17,48	M8	5/16"	4075
345	F100N034	3/4"	19	36	18	19	16	67	47,63	50	22,23	M10	3/8"	4100
345	F102N100	1"	25	38	18	19	16	72	52,37	54	26,19	M10	3/8"	4131
275	F104N114	1 1/4"	31	41	21	22	18	81	58,72	70	30,18	M10	7/16"	4150
200	F106N112	1 1/2"	38	44	25	24	18	95	69,85	78	35,71	M12	1/2"	4187
200	F108N200	2"	50	45	25	26	18	104	77,77	90	42,88	M12	1/2"	4225
170	F110N212	2 1/2"	63	50	25	30	18	116	88,90	102	50,80	M12	1/2"	4275
135	F112N300	3"	73	50	27	34	25	136	106,38	125	61,93	M16	5/8"	4337
35	F114N312	3 1/2"	89	50	27	36	25	153	120,65	137	69,85	M16	5/8"	4387
35	F116N400	4"	99	50	27	36	25	163	130,18	147	77,77	M16	5/8"	4437
35	F118N500	5"	120	50	28	36	25	185	152,40	181	92,08	M16	5/8"	4537

6000 psi

PRESS. MAX bar	TIPO TYPE	A SAE	B	L	H	M	K	C	D	E	F	G Viti/Screws		O-Rings
												Metr.	UNC	
420	F401N038	3/8"	13	36	16	19	14	58	40,49	48	18,24	M8	5/16"	4075
420	F401N012	1/2"	13	36	16	19	14	58	40,49	48	18,24	M8	5/16"	4075
420	F402N034	3/4"	19	36	19	22	16	72	50,80	54	23,80	M10	3/8"	4100
420	F403N100	1"	25	44	24	24	19	81	57,15	70	27,76	M12	7/16"	4131
420	F404N114	1 1/4"	31	44	27	25	22	95	66,68	78	31,75	M14	1/2"	4150
420	F405N112	1 1/2"	38	51	30	28	24	107	79,38	90	36,50	M16	5/8"	4187
420	F406N200	2"	50	70	37	33	32	136	96,82	117	44,45	M20	3/4"	4225
420	F408N212	2 1/2"	63	75	45	35	40	167	123,80	151	58,70	M24	-	4275
420	F410N300	3"	73	90	55	40	55	209	152,40	179	71,40	M30	-	4337

Esempio codice di ordinazione - Ordering example

Flangia
Flange

F404 N114 -

Su richiesta: - On request:

M Viti metriche, rondelle, O-Rings
Metrical screws, washers, O-Rings

U Viti UNC, rondelle, O-Rings
UNC screws, washers, O-Rings

(brunito - burnished)

Flange SAE a saldare di tasca
Weld in SAE flanges

Materiale: Acciaio
Material: Steel

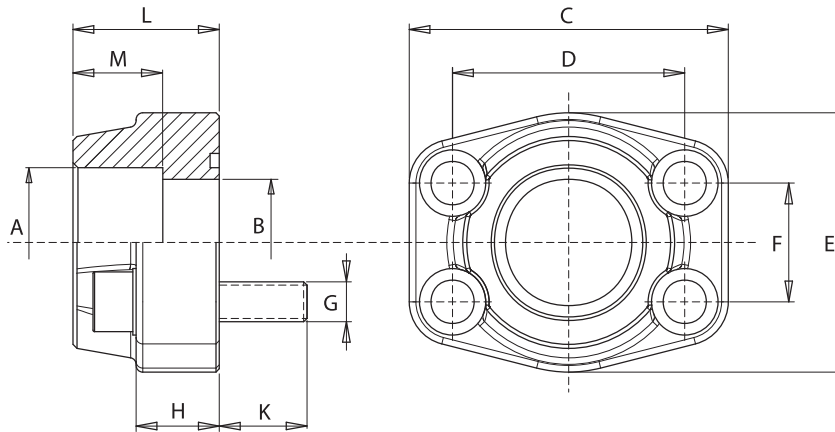

3000 psi

PRESS. MAX bar	TIPO TYPE	A	S.A.E.	B	L	H	M	K	C	D	E	F	G		O-Rings
													Viti/Screws Metr.	UNC	
345	FS080038	17,5	3/8"	13	36	16	18	14	58	38,10	48	17,48	M8	5/16"	4075
345	FS080012	21,6	1/2"	13	36	16	18	14	58	38,10	48	17,48	M8	5/16"	4075
345	FS100034	27,2	3/4"	19	36	18	18	16	67	47,63	50	22,23	M10	3/8"	4100
345	FS102100	34,1	1"	25	38	18	18	16	71	52,37	54	26,19	M10	3/8"	4131
275	FS104114	42,8	1 1/4"	31	41	21	20	18	81	58,72	70	30,18	M10	7/16"	4150
200	FS106112	48,6	1 1/2"	38	44	25	22	18	95	69,85	78	35,71	M12	1/2"	4187
200	FS108200	61	2"	50	45	25	24	18	104	77,77	90	42,88	M12	1/2"	4225
170	FS110212	76,6	2 1/2"	63	50	25	28	18	116	88,90	102	50,80	M12	1/2"	4275
135	FS112300	90,5	3"	73	50	27	28	25	136	106,38	125	61,93	M16	5/8"	4337
35	FS114312	103	3 1/2"	89	50	27	28	25	154	120,65	138	69,85	M16	5/8"	4387
35	FS116400	115,5	4"	99	50	27	28	25	164	130,18	148	77,77	M16	5/8"	4437
35	FS118500	142	5"	120	50	28	28	25	185	152,40	181	92,08	M16	5/8"	4537

6000 psi

PRESS. MAX bar	TIPO TYPE	A	S.A.E.	B	L	H	M	K	C	D	E	F	G		O-Rings
													Viti/Screws Metr.	UNC	
420	FS401038	17,5	3/8"	13	36	16	18	14	58	40,49	48	18,24	M8	5/16"	4075
420	FS401012	21,6	1/2"	13	36	16	18	14	58	40,49	48	18,24	M8	5/16"	4075
420	FS402034	27,2	3/4"	19	36	19	20	16	72	50,80	54	23,80	M10	3/8"	4100
420	FS403100	34,1	1"	25	44	24	22	19	81	57,15	67	27,76	M12	7/16"	4131
420	FS404114	42,8	1 1/4"	31	44	27	22	22	95	66,68	78	31,75	M14	1/2"	4150
420	FS405112	48,6	1 1/2"	38	51	30	24	24	107	79,38	90	36,50	M16	5/8"	4187
420	FS406200	61	2"	50	70	37	25	32	136	96,82	117	44,45	M20	3/4"	4225
420	FS408212	76,6	2 1/2"	63	75	45	28	40	167	123,80	151	58,70	M24	-	4275
420	FS410300	90,5	3"	73	90	55	30	55	209	152,40	179	71,40	M30	-	4337

Esempio codice di ordinazione - Ordering example

FS 108 200 -

Flangia
Flange

Su richiesta: - On request:

M Viti metriche, rondelle, O-Rings
Metrical screws, washers, O-Rings

U Viti UNC, rondelle, O-Rings
UNC screws, washers, O-Rings

(brunite - burnished)

Flange SAE a saldare di testa
Weld on SAE flanges

Materiale: Acciaio

Material: Steel

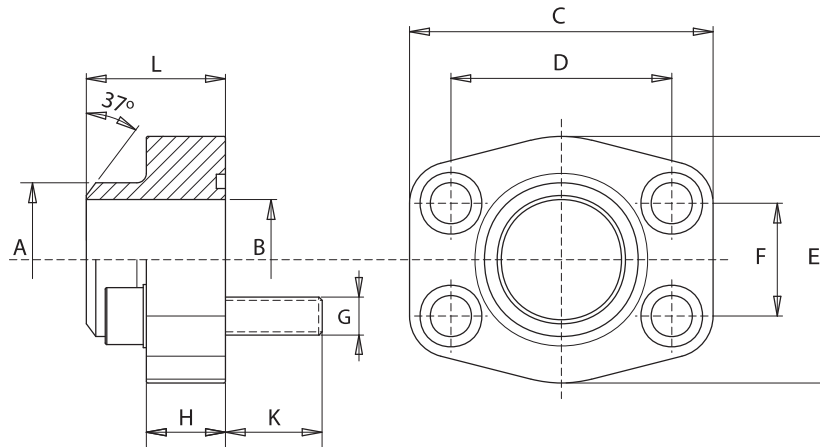

3000 psi

PRESS. MAX bar	TIPO TYPE	A	S.A.E.	B	L	H	K	C	D	E	F	G		O-Rings
												Viti/Screws	O-Rings	
												Metr.	UNC	
345	FT080012	21,6	1/2"	13	36	16	14	58	38,10	48	17,48	M8	5/16"	4075
345	FT100034	27,2	3/4"	19	36	18	16	67	47,63	50	22,23	M10	3/8"	4100
345	FT102100	34,5	1"	25	38	18	16	71	52,37	54	26,19	M10	3/8"	4131
275	FT104114	42,8	1 1/4"	31	41	21	18	81	58,72	70	30,18	M10	7/16"	4150
200	FT106112	48,6	1 1/2"	38	44	25	18	95	69,85	78	35,71	M12	1/2"	4187
200	FT108200	61	2"	50	45	25	18	104	77,77	90	42,88	M12	1/2"	4225
170	FT110212	76,6	2 1/2"	63	50	25	18	116	88,90	102	50,80	M12	1/2"	4275
135	FT112300	89	3"	73	50	27	25	136	106,38	125	61,93	M16	5/8"	4337
35	FT114312	103	3 1/2"	89	50	27	25	154	120,65	138	69,85	M16	5/8"	4387
35	FT116400	115	4"	99	50	27	25	164	130,18	148	77,77	M16	5/8"	4437
35	FT118500	141	5"	120	50	28	25	185	152,40	181	92,08	M16	5/8"	4537

6000 psi

PRESS. MAX bar	TIPO TYPE	A	S.A.E.	B	L	H	K	C	D	E	F	G		O-Rings
												Viti/Screws	O-Rings	
												Metr.	UNC	
420	FT401038	17,5	3/8"	10	36	18	14	58	40,49	48	18,24	M8	5/16"	4075
420	FT401012	21,6	1/2"	13	36	18	14	58	40,49	48	18,24	M8	5/16"	4075
420	FT402034	27,2	3/4"	18	36	18	16	72	50,80	54	23,80	M10	3/8"	4100
420	FT403100	34,5	1"	22	44	24	19	81	57,15	67	27,76	M12	7/16"	4131
420	FT404114	42,8	1 1/4"	28	44	25	22	95	66,68	78	31,75	M14	1/2"	4150
420	FT405112	48,6	1 1/2"	32	51	29	24	107	79,38	90	36,50	M16	5/8"	4187
420	FT406200	61	2"	41	70	35	32	136	96,82	117	44,45	M20	3/4"	4225
420	FT408212	76,6	2 1/2"	50	75	45	40	167	123,80	151	58,70	M24	-	4275
420	FT410300	90	3"	58	90	55	55	209	152,40	179	71,40	M30	-	4337

Esempio codice di ordinazione - Ordering example

FT404 114 -

Flangia
Flange

Su richiesta: - On request:

M Viti metriche, rondelle, O-Rings
Metrical screws, washers, O-Rings

U Viti UNC, rondelle, O-Rings
UNC screws, washers, O-Rings

(brunito - burnished)

Controflangia SAE filettata GAS
BSP threaded SAE counterflanges

Materiale: Acciaio
Material: Steel

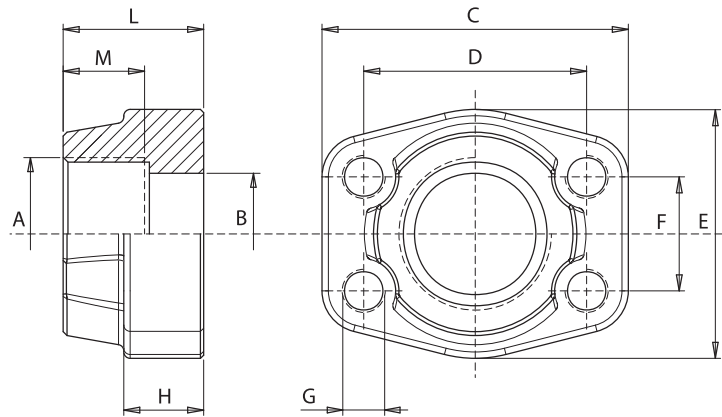

3000 psi

PRESS. MAX bar	TIPO TYPE	A SAE	B	L	H	M	C	D	E	F	G	
											Metr.	UNC
345	CFM080G038	3/8"	13	36	16	19	58	38,10	48	17,48	M8	5/16"
345	CFM080G012	1/2"	13	36	16	19	58	38,10	48	17,48	M8	5/16"
345	CFM100G034	3/4"	19	36	18	19	67	47,63	50	22,23	M10	3/8"
345	CFM102G100	1"	25	38	18	19	72	52,37	54	26,19	M10	3/8"
275	CFM104G114	1 1/4"	31	41	21	22	81	58,72	70	30,18	M10	7/16"
200	CFM106G112	1 1/2"	38	44	25	24	95	69,85	78	35,71	M12	1/2"
200	CFM108G200	2"	50	45	25	26	104	77,77	90	42,88	M12	1/2"
170	CFM110G212	2 1/2"	63	50	25	30	116	88,90	102	50,80	M12	1/2"
135	CFM112G300	3"	73	50	27	34	136	106,38	125	61,93	M16	5/8"
35	CFM114G312	3 1/2"	89	50	27	27	153	120,65	137	69,85	M16	5/8"
35	CFM116G400	4"	99	50	27	30	163	130,18	147	77,77	M16	5/8"
35	CFM118G500	5"	120	50	28	30	185	152,40	181	92,08	M16	5/8"

6000 psi

PRESS. MAX bar	TIPO TYPE	A SAE	B	L	H	M	C	D	E	F	G	
											Metr.	UNC
420	CFM401G038	3/8"	13	36	16	19	58	40,49	48	18,24	M8	5/16"
420	CFM401G012	1/2"	13	36	16	19	58	40,49	48	18,24	M8	5/16"
420	CFM402G034	3/4"	19	36	19	22	72	50,80	54	23,80	M10	3/8"
420	CFM403G100	1"	25	44	24	24	81	57,15	70	27,76	M12	7/16"
420	CFM404G114	1 1/4"	31	44	27	25	95	66,68	78	31,75	M14	1/2"
420	CFM405G112	1 1/2"	38	51	30	28	107	79,38	90	36,50	M16	5/8"
420	CFM406G200	2"	50	70	37	33	136	96,82	117	44,45	M20	3/4"
420	CFM408G212	2 1/2"	63	75	45	35	167	123,80	151	58,70	M24	-
420	CFM410G300	3"	73	90	55	40	209	152,40	179	71,40	M30	-

Esempio codice di ordinazione - Ordering example

CFM404 G114

Controflangia / Counterflange

M Fori fissaggio filettati metrici / Metric tapholes

U Fori fissaggio filettati UNC / UNC tapholes

Controflangia SAE a saldare di tasca
Weld in SAE SAE counterflanges

Materiale: Acciaio
Material: Steel

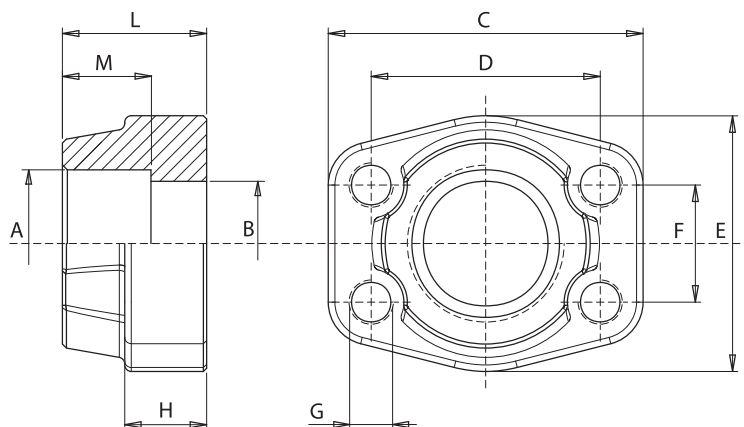

3000 psi

PRESS. MAX bar	TIPO TYPE	S.A.E.	A	B	L	H	M	C	D	E	F	G	
												Metr.	UNC
345	CFSM080038	3/8"	17,5	13	36	16	18	58	38,10	48	17,48	M8	5/16"
345	CFSM080012	1/2"	21,6	13	36	16	18	58	38,10	48	17,48	M8	5/16"
345	CFSM100034	3/4"	27,2	19	36	18	18	67	47,63	50	22,23	M10	3/8"
345	CFSM102100	1"	34,1	25	38	18	18	72	52,37	54	26,19	M10	3/8"
275	CFSM104114	1 1/4"	42,8	31	41	21	20	81	58,72	70	30,18	M10	7/16"
200	CFSM106112	1 1/2"	48,6	38	44	25	22	95	69,85	78	35,71	M12	1/2"
200	CFSM108200	2"	61	50	45	25	24	104	77,77	90	42,88	M12	1/2"
170	CFSM110212	2 1/2"	76,6	63	50	25	28	116	88,90	102	50,80	M12	1/2"
135	CFSM112300	3"	90,5	73	50	27	28	136	106,38	125	61,93	M16	5/8"
35	CFSM114312	3 1/2"	103	89	50	27	28	153	120,65	137	69,85	M16	5/8"
35	CFSM116400	4"	115,5	99	50	27	28	163	130,18	147	77,77	M16	5/8"
35	CFSM118500	5"	142	120	50	28	28	185	152,40	181	92,08	M16	5/8"

6000 psi

PRESS. MAX bar	TIPO TYPE	S.A.E.	A	B	L	H	M	C	D	E	F	G	
												Metr.	UNC
420	CFSM401038	3/8"	17,5	13	36	16	18	58	40,49	48	18,24	M8	5/16"
420	CFSM401012	1/2"	21,6	13	36	16	18	58	40,49	48	18,24	M8	5/16"
420	CFSM402034	3/4"	27,2	19	36	19	20	72	50,80	54	23,80	M10	3/8"
420	CFSM403100	1"	34,1	25	44	24	22	81	57,15	68	27,76	M12	7/16"
420	CFSM404114	1 1/4"	42,8	31	44	27	22	95	66,68	78	31,75	M14	1/2"
420	CFSM405112	1 1/2"	48,6	38	51	30	24	107	79,38	90	36,50	M16	5/8"
420	CFSM406200	2"	61	50	70	37	25	136	96,82	117	44,45	M20	3/4"
420	CFSM408212	2 1/2"	76,6	63	75	45	28	167	123,80	151	58,70	M24	-
420	CFSM410300	3"	90,5	73	90	55	30	209	152,40	179	71,40	M30	-

Esempio codice di ordinazione - Ordering example

CFSM404 114

Controflangia
Counterflange

M Fori fissaggio filettati metrici
Metric tapholes

U Fori fissaggio filettati UNC
UNC tapholes

Controflangia SAE a saldare di tasca
Weld in SAE SAE counterflanges

Materiale: Acciaio
Material: Steel

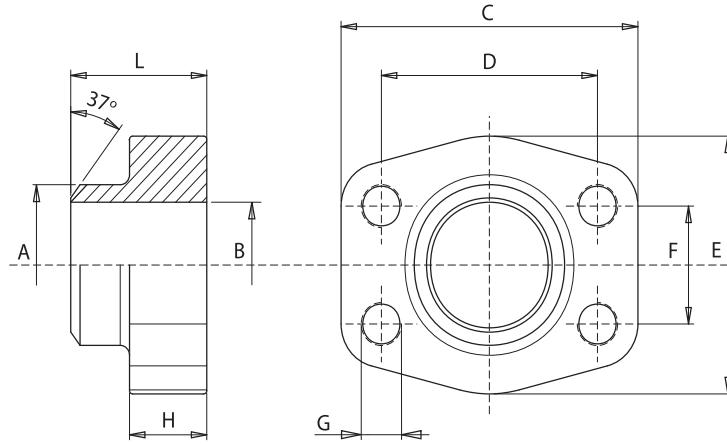

3000 psi

PRESS. MAX bar	TIPO TYPE	S.A.E.	A	B	L	H	C	D	E	F	G	
											Metr.	UNC
345	CFTM080012	1/2"	21,6	13	36	16	58	38,10	48	17,48	M8	5/16"
345	CFTM100034	3/4"	27,2	19	36	18	67	47,63	50	22,23	M10	3/8"
345	CFTM102100	1"	34,5	25	38	18	72	52,37	54	26,19	M10	3/8"
275	CFTM104114	1 1/4"	42,8	31	41	21	81	58,72	70	30,18	M10	7/16"
200	CFTM106112	1 1/2"	48,6	38	44	25	95	69,85	78	35,71	M12	1/2"
200	CFTM108200	2"	61	50	45	25	104	77,77	90	42,88	M12	1/2"
170	CFTM110212	2 1/2"	76,6	63	50	25	116	88,90	102	50,80	M12	1/2"
135	CFTM112300	3"	89	73	50	27	136	106,38	125	61,93	M16	5/8"
35	CFTM114312	3 1/2"	103	89	50	27	153	120,65	137	69,85	M16	5/8"
35	CFTM116400	4"	115	99	50	27	163	130,18	147	77,77	M16	5/8"
35	CFTM118500	5"	141	120	50	28	185	152,40	181	92,08	M16	5/8"

6000 psi

PRESS. MAX bar	TIPO TYPE	S.A.E.	A	B	L	H	C	D	E	F	G	
											Metr.	UNC
420	CFTM401038	3/8"	17,5	10	36	16	58	40,49	48	18,24	M8	5/16"
420	CFTM401012	1/2"	21,6	13	36	16	58	40,49	48	18,24	M8	5/16"
420	CFTM402034	3/4"	27,2	18	36	19	72	50,80	54	23,80	M10	3/8"
420	CFTM403100	1"	34,51	22	44	24	81	57,15	68	27,76	M12	7/16"
420	CFTM404114	1 1/4"	42,8	28	44	27	95	66,68	78	31,75	M14	1/2"
420	CFTM405112	1 1/2"	48,6	32	51	30	107	79,38	90	36,50	M16	5/8"
420	CFTM406200	2"	61	41	70	37	136	96,82	117	44,45	M20	3/4"
420	CFTM408212	2 1/2"	76,6	50	75	45	167	123,80	151	58,70	M24	-
420	CFTM410300	3"	90,5	58	90	55	209	152,40	179	71,40	M30	-

Esempio codice di ordinazione - Ordering example

CFTM404 114

Controflangia
Counterflange

M Fori fissaggio filettati metrici
Metric tapholes

U Fori fissaggio filettati UNC
UNC tapholes

Flange doppie SAE filettate GAS
BSP threaded double SAE flanges

Materiale: Acciaio
Material: Steel

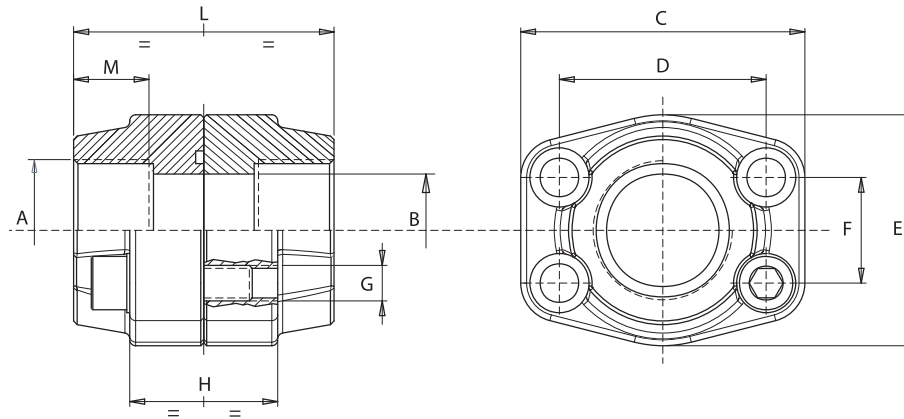

3000 psi

PRESS. MAX bar	TIPO TYPE	A SAE	B	L	H	M	C	D	E	F	G Viti/Screws		O-Rings
											Metr.	UNC	
345	DF080G038	3/8"	13	72	32	19	58	38,10	48	17,48	M8	5/16"	4075
345	DF080G012	1/2"	13	72	32	19	58	38,10	48	17,48	M8	5/16"	4075
345	DF100G034	3/4"	19	72	36	19	67	47,63	50	22,23	M10	3/8"	4100
345	DF102G100	1"	25	76	36	19	72	52,37	54	26,19	M10	3/8"	4131
275	DF104G114	1 1/4"	31	82	42	22	81	58,72	70	30,18	M10	7/16"	4150
200	DF106G112	1 1/2"	38	88	50	24	95	69,85	78	35,71	M12	1/2"	4187
200	DF108G200	2"	50	90	50	26	104	77,77	90	42,88	M12	1/2"	4225
170	DF110G212	2 1/2"	63	100	50	30	116	88,90	102	50,80	M12	1/2"	4275
135	DF112G300	3"	73	100	54	34	136	106,38	125	61,93	M16	5/8"	4337
35	DF114G312	3 1/2"	89	100	54	27	153	120,65	137	69,85	M16	5/8"	4387
35	DF116G400	4"	99	100	54	30	163	130,18	147	77,77	M16	5/8"	4437
35	DF118G500	5"	120	100	56	30	185	152,40	181	92,08	M16	5/8"	4537

6000 psi

PRESS. MAX bar	TIPO TYPE	A SAE	B	L	H	M	C	D	E	F	G Viti/Screws		O-Rings
											Metr.	UNC	
420	DF401G038	3/8"	13	72	32	19	58	40,49	48	18,24	M8	5/16"	4075
420	DF401G012	1/2"	13	72	32	19	58	40,49	48	18,24	M8	5/16"	4075
420	DF402G034	3/4"	19	72	38	22	72	50,80	54	23,80	M10	3/8"	4100
420	DF403G100	1"	25	88	48	24	81	57,15	70	27,76	M12	7/16"	4131
420	DF404G114	1 1/4"	31	88	54	25	95	66,68	78	31,75	M14	1/2"	4150
420	DF405G112	1 1/2"	38	102	60	28	107	79,38	90	36,50	M16	5/8"	4187
420	DF406G200	2"	50	140	74	33	136	96,82	117	44,45	M20	3/4"	4225
420	DF408G212	2 1/2"	63	150	90	35	167	123,80	151	58,70	M24	-	4275
420	DF410G300	3"	73	180	110	40	209	152,40	179	71,40	M30	-	4337

Esempio codice di ordinazione - Ordering example

DF 404 G114 -

Flangia
Flange

M Viti metriche, rondelle, O-Rings
Metrical screws, washers, O-Rings

U Viti UNC, rondelle, O-Rings
UNC screws, washers, O-Rings

(brunite - burnished)

**Flange doppie a saldare di tasca
Weld in double flanges**

Materiale: Acciaio
Material: Steel

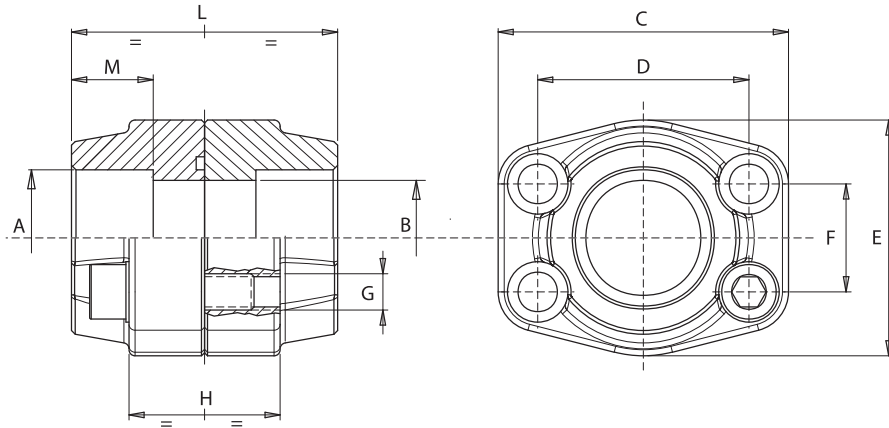

3000 psi

PRESS. MAX bar	TIPO TYPE	S.A.E.	A	B	L	H	M	C	D	E	F	G		O-Rings
												Viti/Screws Metr.	UNC	
345	DFS080038	3/8"	17,5	13	72	32	18	58	38,10	48	17,48	M8	5/16"	4075
345	DFS080012	1/2"	21,6	13	72	32	18	58	38,10	48	17,48	M8	5/16"	4075
345	DFS100034	3/4"	27,2	19	72	36	18	67	47,63	50	22,23	M10	3/8"	4100
345	DFS102100	1"	34,1	25	76	36	18	72	52,37	54	26,19	M10	3/8"	4131
275	DFS104114	1 1/4"	42,8	31	82	42	20	81	58,72	70	30,18	M10	7/16"	4150
200	DFS106112	1 1/2"	48,6	38	88	50	22	95	69,85	78	35,71	M12	1/2"	4187
200	DFS108200	2"	61	50	90	50	24	104	77,77	90	42,88	M12	1/2"	4225
170	DFS110212	2 1/2"	76,6	63	100	50	28	117	88,90	102	50,80	M12	1/2"	4275
135	DFS112300	3"	90,5	73	100	54	28	136	106,38	125	61,93	M16	5/8"	4337
35	DFS114312	3 1/2"	103	89	100	54	28	154	120,65	138	69,85	M16	5/8"	4387
35	DFS116400	4"	115,5	99	100	54	28	164	130,18	148	77,77	M16	5/8"	4437
35	DFS118500	5"	142	120	100	56	28	185	152,40	181	92,08	M16	5/8"	4537

6000 psi

PRESS. MAX bar	TIPO TYPE	S.A.E.	A	B	L	H	M	C	D	E	F	G		O-Rings
												Viti/Screws Metr.	UNC	
420	DFS401038	3/8"	17,5	13	72	32	18	58	40,49	48	18,24	M8	5/16"	4075
420	DFS401012	1/2"	21,6	13	72	32	18	58	40,49	48	18,24	M8	5/16"	4075
420	DFS402034	3/4"	27,2	19	72	38	20	72	50,80	54	23,80	M10	3/8"	4100
420	DFS403100	1"	34,1	25	88	48	22	81	57,15	67	27,76	M12	7/16"	4131
420	DFS404114	1 1/4"	42,8	31	88	54	22	95	66,68	78	31,75	M14	1/2"	4150
420	DFS405112	1 1/2"	48,6	38	102	60	24	107	79,38	90	36,50	M16	5/8"	4187
420	DFS406200	2"	61	50	140	74	25	136	96,82	117	44,45	M20	3/4"	4225
420	DFS408212	2 1/2"	76,6	63	150	90	28	167	123,80	151	58,70	M24	-	4275
420	DFS410300	3"	90,5	73	180	110	30	209	152,40	179	71,40	M30	-	4337

Esempio codice di ordinazione - Ordering example

DFS 104 114 - **M** Viti metriche, rondelle, O-Rings
Metrical screws, washers, O-Rings

U Viti UNC, rondelle, O-Rings
UNC screws, washers, O-Rings

(brunite - burnished)

Flangia
Flange

Flange doppie a saldare di tasca
Weld in double flanges

Materiale: Acciaio
Material: Steel

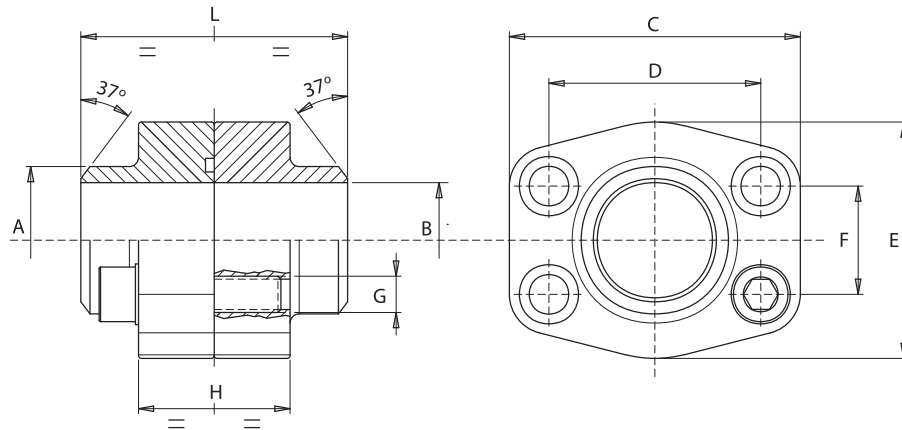

3000 psi

PRESS. MAX bar	TIPO TYPE	S.A.E.	A	B	L	H	C	D	E	F	G		O-Rings
											Viti/Screws		
											Metr.	UNC	
345	DFT080012	1/2"	21,6	13	72	32	58	38,10	48	17,48	M8	5/16"	4075
345	DFT100034	3/4"	27,2	19	72	36	67	47,63	50	22,23	M10	3/8"	4100
345	DFT102100	1"	34,5	25	76	36	72	52,37	54	26,19	M10	3/8"	4131
345	DFT104114	1 1/4"	42,8	31	82	42	81	58,72	70	30,18	M10	7/16"	4150
275	DFT106112	1 1/2"	48,6	38	88	50	95	69,85	78	35,71	M12	1/2"	4187
200	DFT108200	2"	61	50	90	50	104	77,77	90	42,88	M12	1/2"	4225
200	DFT110212	2 1/2"	76,6	63	100	50	116	88,90	102	50,80	M12	1/2"	4275
170	DFT112300	3"	89	73	100	54	136	106,38	125	61,93	M16	5/8"	4337
135	DFT114312	3 1/2"	103	89	100	54	154	120,65	138	69,85	M16	5/8"	4387
35	DFT116400	4"	115	99	100	54	164	130,18	148	77,77	M16	5/8"	4437
35	DFT118500	5"	141	120	100	56	185	152,40	181	92,08	M16	5/8"	4537

6000 psi

PRESS. MAX bar	TIPO TYPE	S.A.E.	A	B	L	H	C	D	E	F	G		O-Rings
											Viti/Screws		
											Metr.	UNC	
420	DFT401038	3/8"	17,5	10	72	34	58	40,49	48	18,24	M8	5/16"	4075
420	DFT401012	1/2"	21,6	13	72	34	58	40,49	48	18,24	M8	5/16"	4075
420	DFT402034	3/4"	27,2	18	72	37	72	50,80	54	23,80	M10	3/8"	4100
420	DFT403100	1"	34,5	22	88	48	81	57,15	68	27,76	M12	7/16"	4131
420	DFT404114	1 1/4"	42,8	28	88	52	95	66,68	78	31,75	M14	1/2"	4150
420	DFT405112	1 1/2"	48,6	32	102	59	107	79,38	90	36,50	M16	5/8"	4187
420	DFT406200	2"	61	41	140	72	136	96,82	117	44,45	M20	3/4"	4225
420	DFT408212	2 1/2"	76,6	50	150	90	167	123,80	151	58,70	M24	-	4275
420	DFT410300	3"	90	58	180	110	209	152,40	179	71,40	M30	-	4337

Esempio codice di ordinazione - Ordering example

DFT 404 114 -

Flangia
Flange

M Viti metriche, rondelle, O-Rings
Metrical screws, washers, O-Rings

U Viti UNC, rondelle, O-Rings
UNC screws, washers, O-Rings

(brunite - burnished)

Flange cieche
Blind flanges

Materiale: Acciaio
Material: Steel

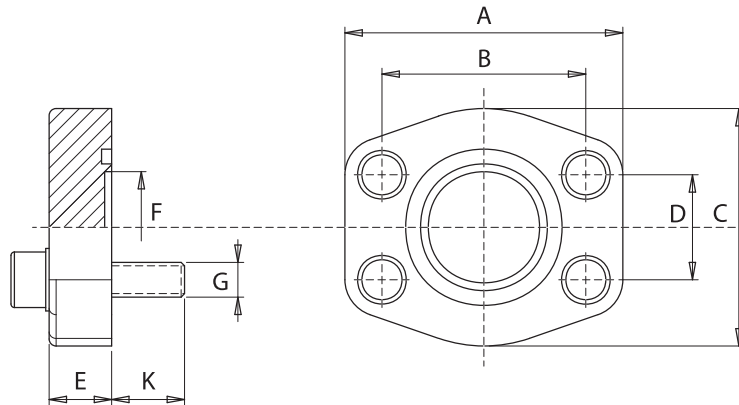

3000 psi

PRESS. MAX bar	TIPO TYPE	S.A.E.	A	B	C	D	E	F	K	G		O-Rings
										Viti/Screws		
										Metr.	UNC	
345	C080012	1/2"	58	38,10	48	17,48	16	10	14	M8	5/16"	4075
345	C100034	3/4"	67	47,63	50	22,23	18	15	16	M10	3/8"	4100
345	C102100	1"	72	52,37	54	26,19	19	18	16	M10	3/8"	4131
275	C104114	1 1/4"	80	58,72	70	30,18	21	23	18	M10	7/16"	4150
200	C106112	1 1/2"	96	69,85	78	35,71	24	28	19	M12	1/2"	4187
200	C108200	2"	104	77,77	90	42,88	24	45	19	M12	1/2"	4225
175	C110212	2 1/2"	117	88,90	102	50,80	25	58	19	M12	1/2"	4275
135	C112300	3"	137	106,38	125	61,93	25	70	27	M16	5/8"	4337
35	C114312	3 1/2"	153	120,65	137	69,85	25	85	27	M16	5/8"	4387
35	C116400	4"	163	130,18	147	77,77	25	95	27	M16	5/8"	4437
35	C118500	5"	185	152,40	181	92,08	25	110	27	M16	5/8"	4537

6000 psi

PRESS. MAX bar	TIPO TYPE	S.A.E.	A	B	C	D	E	F	K	G		O-Rings
										Viti/Screws		
										Metr.	UNC	
420	C401012	3/8"	58	40,49	48	18,24	16	10	14	M8	5/16"	4075
420	C402034	3/4"	72	50,80	54	23,80	19	15	16	M10	3/8"	4100
420	C403100	1"	80	57,15	67	27,76	24	22	18	M12	7/16"	4131
420	C404114	1 1/4"	95	66,68	78	31,75	27	30	24	M14	1/2"	4150
420	C405112	1 1/2"	104	79,38	90	36,50	30	35	24	M16	5/8"	4187
420	C406200	2"	136	96,82	124	44,45	35	48	31	M20	3/4"	4225
420	C408212	2 1/2"	167	123,80	150	58,70	45	55	40	M24	-	4275
420	C410300	3"	209	152,4	179	71,40	55	65	45	M30	-	4337

Esempio codice di ordinazione - Ordering example

C 112 300 - **M** **U**
 Flangia / Flange
 Su richiesta: - On request:
M Viti metriche, rondelle, O-Rings / Metrical screws, washers, O-Rings
U Viti UNC, rondelle, O-Rings / UNC screws, washers, O-Rings
 (brunite - burnished)

Flange SAE filettate GAS 90°
90° BSP threaded SAE flanges

Materiale: Acciaio
Material: Steel

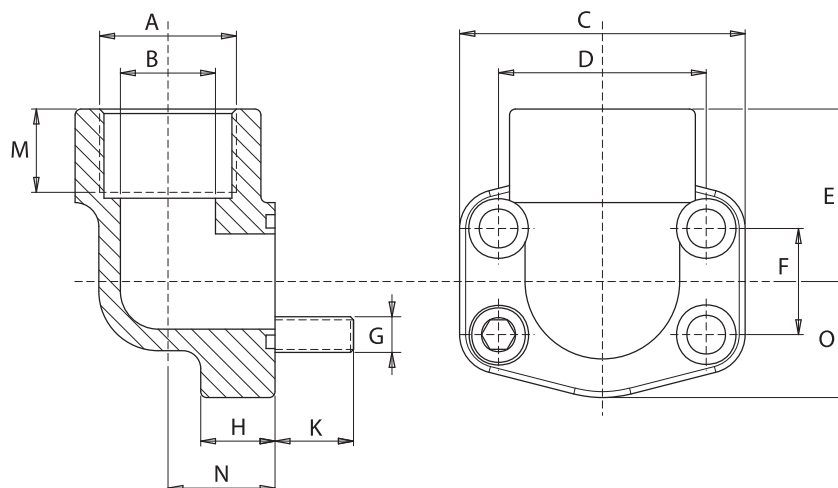

3000 psi

PRESS. MAX bar	TIPO TYPE	A SAE	B	M	C	D	E	O	F	H	N	K	G		O-Rings
													Viti/Screws Metr.	UNC	
345	F90280G012	1/2"	13	20	58	38,10	37	23	17,48	17	18	13	M8	5/16"	4075
345	F90300G034	3/4"	19	20	69	47,63	39	25	22,23	18	22	15	M10	3/8"	4100
345	F90302G100	1"	25	20	75	52,37	42	27	26,19	19	28	15	M10	3/8"	4131
275	F90304G114	1 1/4"	31	23	82	58,72	50	34	30,18	22	30	17	M10	7/16"	4150
200	F90306G112	1 1/2"	38	25	96	69,85	59	39	35,71	25	36	18	M12	1/2"	4187
200	F90308G200	2"	50	27	106	77,77	66	44	42,88	25	41	18	M12	1/2"	4225
170	F90310G212	2 1/2"	60	31	116	88,90	78	50	50,80	25	50	18	M12	1/2"	4275

6000 psi

PRESS. MAX bar	TIPO TYPE	A SAE	B	M	C	D	E	O	F	H	N	K	G		O-Rings
													Viti/Screws Metr.	UNC	
420	F90580G012	1/2"	13	20	58	40,49	37	23	18,24	17	18	13	M8	5/16"	4075
420	F90600G034	3/4"	19	23	73	50,80	42	28	23,80	20	28	15	M10	3/8"	4100
420	F90602G100	1"	25	25	83	57,15	50	34	27,76	24	30	19	M12	7/16"	4131
420	F90604G114	1 1/4"	31	27	96	66,68	59	40	31,75	25	36	21	M14	1/2"	4150
420	F90606G112	1 1/2"	38	29	110	79,38	66	45	36,50	26	41	25	M16	5/8"	4187
420	F90608G200	2"	50	35	135	96,82	76	59	44,45	35	45	32	M20	3/4"	4225

Esempio codice di ordinazione - Ordering example

Flangia
Flange

F90 308 G200 -

Su richiesta: - On request:

M Viti metriche, rondelle, O-Rings
Metrical screws, washers, O-Rings

U Viti UNC, rondelle, O-Rings
UNC screws, washers, O-Rings

(brunite - burnished)

**Flange SAE filettate NPT 90°
90° NPT threaded SAE flanges**

Materiale: Acciaio
Material: Steel

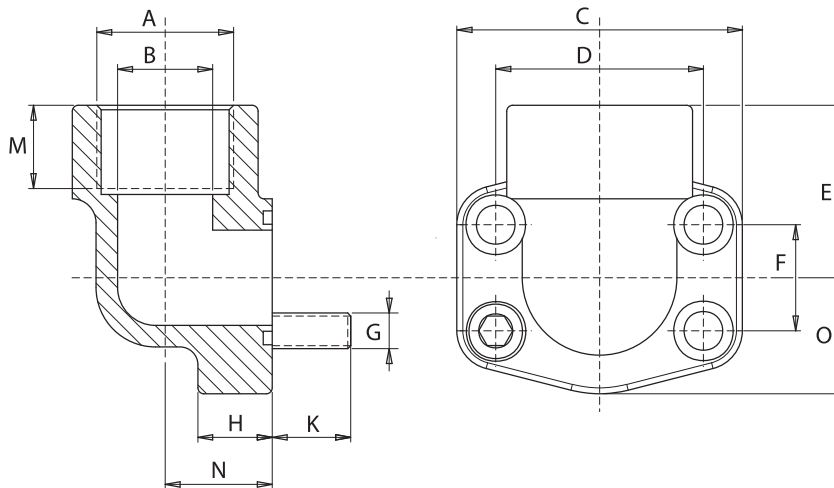

3000 psi

PRESS. MAX bar	TIPO TYPE	A SAE	B	M	C	D	E	O	F	H	N	K	G		O-Rings
													Viti/Screws Metr.	UNC	
345	F90280N012	1/2"	13	20	58	38,10	37	23	17,48	17	18	13	M8	5/16"	4075
345	F90300N034	3/4"	19	20	69	47,63	39	25	22,23	18	22	15	M10	3/8"	4100
345	F90302N100	1"	25	20	75	52,37	42	27	26,19	19	28	15	M10	3/8"	4131
275	F90304N114	1 1/4"	31	23	82	58,72	50	34	30,18	22	30	17	M10	7/16"	4150
200	F90306N112	1 1/2"	38	25	96	69,85	59	39	35,71	25	36	18	M12	1/2"	4187
200	F90308N200	2"	50	27	106	77,77	66	44	42,88	25	41	18	M12	1/2"	4225
170	F90310N212	2 1/2"	60	31	116	88,90	78	50	50,80	25	50	18	M12	1/2"	4275

6000 psi

PRESS. MAX bar	TIPO TYPE	A SAE	B	M	C	D	E	O	F	H	N	K	G		O-Rings
													Viti/Screws Metr.	UNC	
420	F90580N012	1/2"	13	20	58	40,49	37	23	18,24	17	18	13	M8	5/16"	4075
420	F90300N034	3/4"	19	23	73	50,80	42	28	23,80	20	28	15	M10	3/8"	4100
420	F90602N100	1"	25	25	83	57,15	50	34	27,76	24	30	19	M12	7/16"	4131
420	F90604N114	1 1/4"	31	27	96	66,68	59	40	31,75	25	36	21	M14	1/2"	4150
420	F90606N112	1 1/2"	38	29	110	79,38	66	45	36,50	26	41	25	M16	5/8"	4187
420	F90608N200	2"	50	35	135	96,82	76	59	44,45	35	45	32	M20	3/4"	4225

Esempio codice di ordinazione - Ordering example

Flangia
Flange

F90 308 N200 -

Su richiesta: - On request:

M Viti metriche, rondelle, O-Rings
Metrical screws, washers, O-Rings

U Viti UNC, rondelle, O-Rings
UNC screws, washers, O-Rings

(brunite - burnished)

Flange SAE a saldare di tasca a 90°
90° weld in SAE flanges

Materiale: Acciaio
Material: Steel

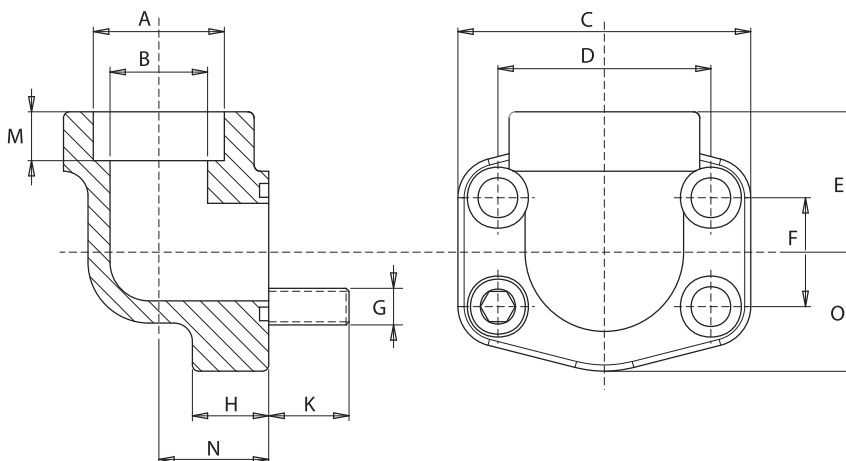

3000 psi

PRESS. MAX bar	TIPO TYPE	S.A.E.	A	B	M	C	D	E	O	F	H	N	K	G		O-Rings
														Viti/Screws Metr.	UNC	
345	FS90280012	1/2"	21,6	13	5	58	38,10	29	24	17,48	17	18	13	M8	5/16"	4075
345	FS90300034	3/4"	27,2	19	5	69	47,63	26	26	22,23	18	22	15	M10	3/8"	4100
345	FS90302100	1"	34,1	25	6	73	52,37	29	28	26,19	19	28	15	M10	3/8"	4131
275	FS90304114	1 1/4"	42,8	31	7	83	58,72	35	35	30,18	22	30	17	M10	7/16"	4150
200	FS90306112	1 1/2"	48,6	38	8	96	69,85	44	40	35,71	25	36	18	M12	1/2"	4187
200	FS90308200	2"	61	50	10	106	77,77	51	45	42,88	25	41	18	M12	1/2"	4225
170	FS90310212	2 1/2"	76,6	60	28	116	88,90	78	50	50,80	25	50	18	M12	1/2"	4275

6000 psi

PRESS. MAX bar	TIPO TYPE	S.A.E.	A	B	M	C	D	E	O	F	H	N	K	G		O-Rings
														Viti/Screws Metr.	UNC	
420	FS90580012	1/2"	21,6	13	5	58	40,49	29	24	18,24	17	18	13	M8	5/16"	4075
420	FS90600034	3/4"	27,2	19	6	73	50,80	29	28	23,80	19	28	15	M10	3/8"	4100
420	FS90602100	1"	24,1	25	7	83	57,15	35	35	27,76	24	30	19	M12	7/16"	4131
420	FS90604114	1 1/4"	42,8	31	8	96	66,68	44	40	31,75	25	36	21	M14	1/2"	4150
420	FS90606112	1 1/2"	48,6	38	10	110	79,38	50	45	36,50	26	41	25	M16	5/8"	4187
420	FS90608200	2"	61	50	12	135	96,82	66	59	44,45	35	45	32	M20	3/4"	4225

Esempio codice di ordinazione - Ordering example

Su richiesta: - On request:

FS90 304 114 - **M** Viti metriche, rondelle, O-Rings
Metrical screws, washers, O-Rings

U Viti UNC, rondelle, O-Rings
UNC screws, washers, O-Rings
(brunite - burnished)

Flangia
Flange

**Flange SAE a saldare di testa a 90°
90° weld on SAE flanges**

Materiale: Acciaio
Material: Steel

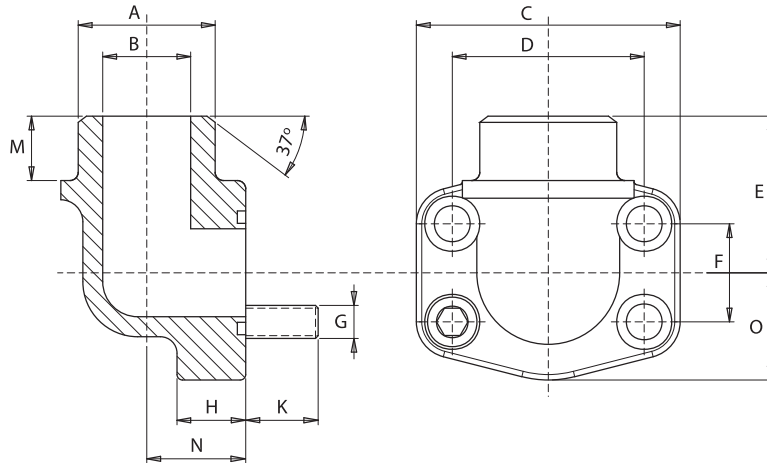

3000 psi

PRESS. MAX bar	TIPO TYPE	S.A.E.	A	B	M	C	D	E	O	F	H	N	K	G		O-Rings
														Viti/Screws Metr.	UNC	
345	FT90280012	1/2"	21,6	13	12	58	38,10	40	24	17,48	17	18	13	M8	5/16"	4075
345	FT90300034	3/4"	27,2	19	12	69	47,63	42	26	22,23	18	22	15	M10	3/8"	4100
345	FT90302100	1"	34,5	25	13	73	52,37	50	28	26,19	19	28	15	M10	3/8"	4131
275	FT90304114	1 1/4"	42,8	31	13	83	58,72	58	35	30,18	22	30	17	M10	7/16"	4150
200	FT90306112	1 1/2"	48,6	38	14	96	69,85	67	40	35,71	25	36	18	M12	1/2"	4187
200	FT90308200	2"	61	50	15	106	77,77	67	45	42,88	25	41	18	M12	1/2"	4225
170	FT90310212	2 1/2"	76,6	60	25	116	88,90	78	51	50,80	25	50	18	M12	1/2"	4275

6000 psi

PRESS. MAX bar	TIPO TYPE	S.A.E.	A	B	M	C	D	E	O	F	H	N	K	G		O-Rings
														Viti/Screws Metr.	UNC	
420	FT90580012	1/2"	21,6	13	12	58	40,49	40	24	18,24	17	18	13	M8	5/16"	4075
420	FT90600034	3/4"	27,2	18	12	73	50,80	50	28	23,80	20	28	15	M10	3/8"	4100
420	FT90602100	1"	34,5	22	13	83	57,15	58	35	27,76	24	30	19	M12	7/16"	4131
420	FT90604114	1 1/4"	42,8	28	13	96	66,68	67	40	31,75	25	36	21	M14	1/2"	4150
420	FT90606112	1 1/2"	48,6	32	15	110	79,38	66	45	36,50	26	41	25	M16	5/8"	4187
420	FT90608200	2"	61	41	15	135	96,82	76	59	44,45	35	45	32	M20	3/4"	4225

Esempio codice di ordinazione - Ordering example

Flangia
Flange

FT90 602 100 -

Su richiesta: - On request:

M Viti metriche, rondelle, O-Rings
Metrical screws, washers, O-Rings

U Viti UNC, rondelle, O-Rings
UNC screws, washers, O-Rings

(brunite - burnished)

Semiflanguia SAE intera
Uncut SAE split flanges

Materiale: Acciaio
Material: Steel

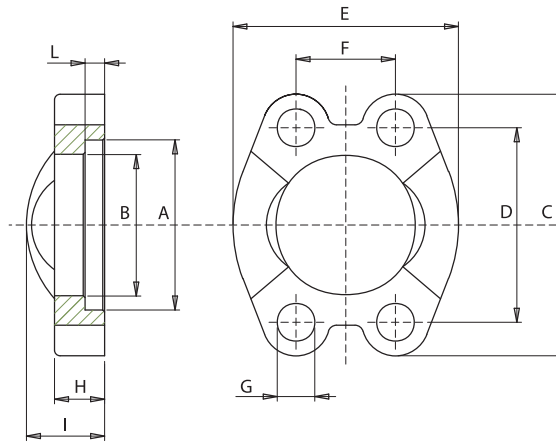

3000 psi

PRESS. MAX bar	TIPO TYPE	S.A.E.	A	B	C	D	E	F	G	H	I	L
210	SFI3001012	1/2"	31	24,3	55	38,10	46	17,48	8,75	13	20	6,2
210	SFI3002034	3/4"	38,9	32,1	66	47,63	52	22,23	10,5	14	22	6,2
210	SFI3003100	1"	45,2	38,5	69	52,37	59	26,19	10,5	16	24	7,5
210	SFI3004114A	1 1/4"	51,6	43,7	79	58,72	73	30,18	10,5	14	22	7,5
210	SFI3004114	1 1/4"	51,6	43,7	79	58,72	73	30,18	12	14	22	7,5
210	SFI3004114B	1 1/4"	51,6	43,7	79	58,72	73	30,18	12,5	14	22	7,5
210	SFI3005112	1 1/2"	61,1	50,8	95	69,85	83	35,71	13,5	16	25	7,5
210	SFI3005112B	1 1/2"	61,1	50,8	95	69,85	83	35,71	14,5	16	25	7,5
210	SFI3006200	2"	72,2	62,7	103	77,77	97	42,88	13,5	16	26	9
210	SFI3006200B	2"	72,2	62,7	103	77,77	97	42,88	14,5	16	26	9
175	SFI3007212	2 1/2"	84,9	74,9	114	88,90	109	50,80	13,5	19	38	9
175	SFI3007212B	2 1/2"	84,9	74,9	114	88,90	109	50,80	14,5	19	38	9
135	SFI3008300	3"	102,4	90,9	136	106,38	131	61,93	17	22	41	9
35	SFI3009312	3 1/2"	115	102,36	151	120,65	140	69,85	17	23	45	10,7
35	SFI3010400	4"	127,8	115,1	161	130,18	150	77,77	17	25	48	10,7
35	SFI3011500	5"	153,2	140,5	182	152,40	180	92,08	17	28	50	10,7

6000 psi

PRESS. MAX bar	TIPO TYPE	S.A.E.	A	B	C	D	E	F	G	H	I	L
420	SFI6001012	1/2"	32,5	24,6	58	40,49	48	18,24	8,75	16	22	7,2
420	SFI6002034	3/4"	42	32,5	71	50,80	60	23,80	10,5	19	28	8,3
420	SFI6003100	1"	48,4	38,9	80	57,15	70	27,76	13	24	32	9
420	SFI6004114	1 1/4"	54,8	44,5	97	66,68	78	31,75	15	27	38	9,8
420	SFI6005112	1 1/2"	64,3	51,6	112	79,38	96	36,50	17	30	42	12,1
420	SFI6006200	2"	80,2	67,6	135	96,82	114	44,45	21	37	52	12,1
420	SFI6008212	2 1/2"	108,5	89,5	174	123,80	150	58,70	25	48	48	20
420	SFI6010300	3"	132,5	114,5	209	152,40	178	71,40	32	58	58	25

Esempio codice di ordinazione - Ordering example

Su richiesta: - On request:

SFI 3004 114B

M

Viti metriche, rondelle, O-Rings
Metrical screws, washers, O-Rings

Semiflanguia
Splitflange

Particolare zincato bianco - White zinc plated

**Semiflanguia SAE intera con fori filettati metrici
Uncut SAE split flanges with metric threaded fixing holes**

Materiale: Acciaio
Material: Steel

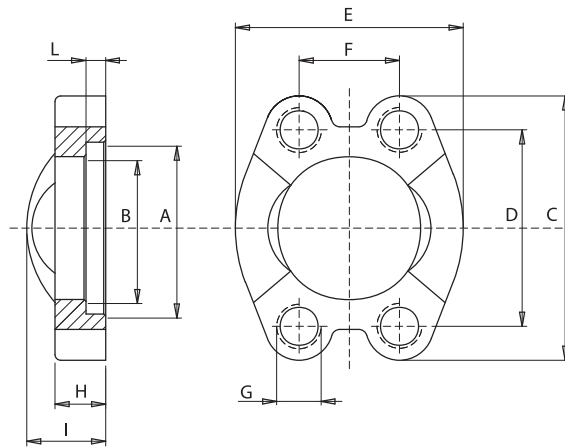

3000 psi

PRESS. MAX bar	TIPO TYPE	S.A.E.	A	B	C	D	E	F	G	H	I	L
210	SFIM3001012	1/2"	31	24,3	55	38,10	46	17,48	M8	13	20	6,2
210	SFIM3002034	3/4"	38,9	32,1	66	47,63	52	22,23	M10	14	22	6,2
210	SFIM3003100	1"	45,2	38,5	69	52,37	59	26,19	M10	16	24	7,5
210	SFIM3004114	1 1/4"	51,6	43,7	79	58,72	73	30,18	M10	14	22	7,5
210	SFIM3004114B	1 1/4"	51,6	43,7	79	58,72	73	30,18	M12	14	22	7,5
210	SFIM3005112	1 1/2"	61,1	50,8	95	69,85	83	35,71	M12	16	25	7,5
210	SFIM3005112B	1 1/2"	61,1	50,8	95	69,85	83	35,71	M14	16	25	7,5
210	SFIM3006200	2"	72,2	62,7	103	77,77	97	42,88	M12	16	26	9
210	SFIM3006200B	2"	72,2	62,7	103	77,77	97	42,88	M14	16	26	9
175	SFIM3007212	2 1/2"	84,9	74,9	114	88,90	109	50,80	M12	19	38	9
175	SFIM3007212B	2 1/2"	84,9	74,9	114	88,90	109	50,80	M14	19	38	9
135	SFIM3008300	3"	102,4	90,9	136	106,38	131	61,93	M16	22	41	9
35	SFIM3009312	3 1/2"	115	102,36	151	120,65	140	69,85	M16	23	45	10,7
35	SFIM3010400	4"	127,8	115,1	161	130,18	150	77,77	M16	25	48	10,7
35	SFIM3011500	5"	153,2	140,5	182	152,40	180	92,08	M16	28	50	10,7

6000 psi

PRESS. MAX bar	TIPO TYPE	S.A.E.	A	B	C	D	E	F	G	H	I	L
420	SFIM6001012	1/2"	32,5	24,6	58	40,49	48	18,24	M8	16	22	7,2
420	SFIM6002034	3/4"	42	32,5	71	50,80	60	23,80	M10	19	28	8,3
420	SFIM6003100	1"	48,4	38,9	80	57,15	70	27,76	M12	24	32	9
420	SFIM6004114	1 1/4"	54,8	44,5	97	66,68	78	31,75	M14	27	38	9,8
420	SFIM6005112	1 1/2"	64,3	51,6	112	79,38	96	36,50	M16	30	42	12,1
420	SFIM6006200	2"	80,2	67,6	135	96,82	114	44,45	M20	37	52	12,1
420	SFIM6008212	2 1/2"	108,5	89,5	174	123,80	150	58,70	M24	48	48	20
420	SFIM6010300	3"	132,5	114,5	209	152,40	178	71,40	M30	58	58	25

Esempio codice di ordinazione - Ordering example

SFIM 3004 114B

Semiflanguia
Splitflange

Particolare zincato bianco - White zinc plated

Semiflanguia SAE tagliata
SAE split flanges

Materiale: Acciaio
Material: Steel

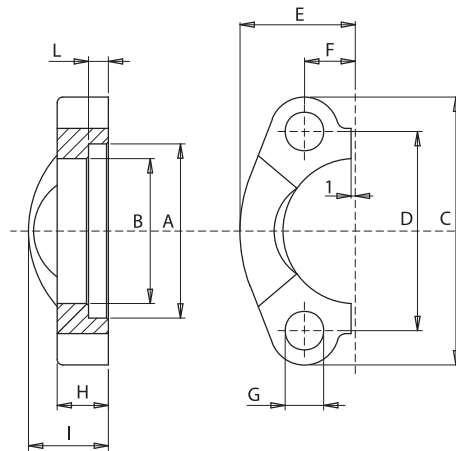

3000 psi

PRESS. MAX bar	TIPO TYPE	S.A.E.	A	B	C	D	E	F	G	H	I	L
210	SFT3001012	1/2"	31	24,3	55	38,10	23	8,74	8,75	13	20	6,2
210	SFT3002034	3/4"	38,9	32,1	66	47,63	26	11,13	10,5	14	22	6,2
210	SFT3003100	1"	45,2	38,5	69	52,37	29,2	13,08	10,5	16	24	7,5
210	SFT3004114A	1 1/4"	51,6	43,7	79	58,72	36,3	15,09	10,5	14	22	7,5
210	SFT3004114	1 1/4"	51,6	43,7	79	58,72	36,3	15,09	12	14	22	7,5
210	SFT3004114B	1 1/4"	51,6	43,7	79	58,72	36,3	15,09	12,5	14	22	7,5
210	SFT3005112	1 1/2"	61,1	50,8	95	69,85	41,1	17,86	13,5	16	25	7,5
210	SFT3005112B	1 1/2"	61,1	50,8	95	69,85	41,1	17,86	14,5	16	25	7,5
210	SFT3006200	2"	72,2	62,7	103	77,77	48,2	21,44	13,5	16	26	9
210	SFT3006200B	2"	72,2	62,7	103	77,77	48,2	21,44	14,5	16	26	9
175	SFT3007212	2 1/2"	84,9	74,9	114	88,90	54	25,40	13,5	19	38	9
175	SFT3007212B	2 1/2"	84,9	74,9	114	88,90	54	25,40	14,5	19	38	9
135	SFT3008300	3"	102,4	90,9	136	106,38	65,3	30,96	17	22	41	9
35	SFT3009312	3 1/2"	115	102,36	151	120,65	70	34,92	17	23	45	10,7
35	SFT3010400	4"	127,8	115,1	161	130,18	75	38,88	17	25	48	10,7
35	SFT3011500	5"	153,2	140,5	182	152,40	82	46,04	17	28	50	10,7

6000 psi

PRESS. MAX bar	TIPO TYPE	S.A.E.	A	B	C	D	E	F	G	H	I	L
420	SFT6001012	1/2"	32,5	24,6	58	40,49	24	9,12	8,75	16	22	7,2
420	SFT6002034	3/4"	42	32,5	71	50,80	30	11,91	10,5	19	28	8,3
420	SFT6003100	1"	48,4	38,9	80	57,15	35	13,89	13	24	32	9
420	SFT6004114	1 1/4"	54,8	44,5	97	66,68	39	15,88	15	27	38	9,8
420	SFT6005112	1 1/2"	64,3	51,6	112	79,38	48	18,26	17	30	42	12,1
420	SFT6006200	2"	80,2	67,6	135	96,82	57	22,23	21	37	52	12,1
420	SFT6008212	2 1/2"	108,5	89,5	174	123,80	75	29,35	25	48	48	20
420	SFT6010300	3"	132,5	114,5	209	152,40	89	35,7	32	58	58	25

Esempio codice di ordinazione - Ordering example

SFT 3004 114B

Semiflanguia
Splitflange

Su richiesta: - On request:
M Viti metriche, rondelle, O-Rings
Metrical screws, washers, O-Rings

Il codice si riferisce alla coppia di semiflange
The code refers to the spit flanges pair

Particolare zincato bianco - White zinc plated

Coduli SAE a saldare di testa
Weld on SAE adaptors

Materiale: Acciaio
Material: Steel

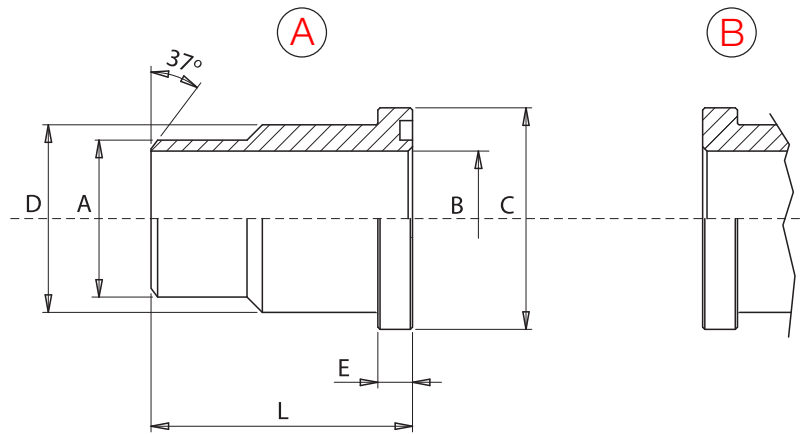

3000 psi

PRESS. MAX bar	TIPO TYPE	TAGLIA SIZE	A	B	C	D	E	L	O-Rings
275	CST3021012	1/2"	22	13	30,2	24	6,7	45	4075
275	CST3027034	3/4"	28	19	38,1	31,5	6,7	50	4100
275	CST3033100	1"	35	25	44,4	38	8	55	4131
275	CST3042114	1 1/4"	43	31	50,8	43	8	60	4150
275	CST3049112	1 1/2"	50	38	60,3	50	8	65	4187
275	CST3060200	2"	62	47	71,4	62	9,5	70	4225
175	CST3075212	2 1/2"	74	63	84,1	74	9,5	75	4275
135	CST3090300	3"	90	70	101,6	90	9,5	85	4337
35	CST3103312	3 1/2"	102	88	114,3	102	11,2	90	4387
35	CST3115400	4"	115	98	127	114	11,2	100	4437
35	CST3140500	5"	140	120	152,4	140	11,2	100	4537

6000 psi

PRESS. MAX bar	TIPO TYPE	TAGLIA SIZE	A	B	C	D	E	L	O-Rings
420	CST6021012	1/2"	22	13	31,8	24	7,7	45	4075
420	CST6027034	3/4"	28	18	41,3	32	8,7	50	4100
420	CST6033100	1"	35	22	47,6	38	9,5	55	4131
420	CST6042114	1 1/4"	44	29	54	44	10,3	60	4150
420	CST6049112	1 1/2"	51	35	63,5	51	12,5	65	4187
420	CST6060200	2"	61	43	79,4	67	12,5	70	4225
420	CST6075212	2 1/2"	74	45	107,8	88,9	20,6	90	4275
420	CST6090300	3"	90	58	131,7	113,8	25,6	110	4337

Esempio codice di ordinazione - Ordering example

CST 6049 112 - A Con sede O-Ring
B Senza sede O-Ring
 Codulo Adaptor Without O-Ring seat

**Flangia SAE 90° - L BLOCK
SAE 90° - L BLOCK flanges**

Materiale: Acciaio
Material: Steel

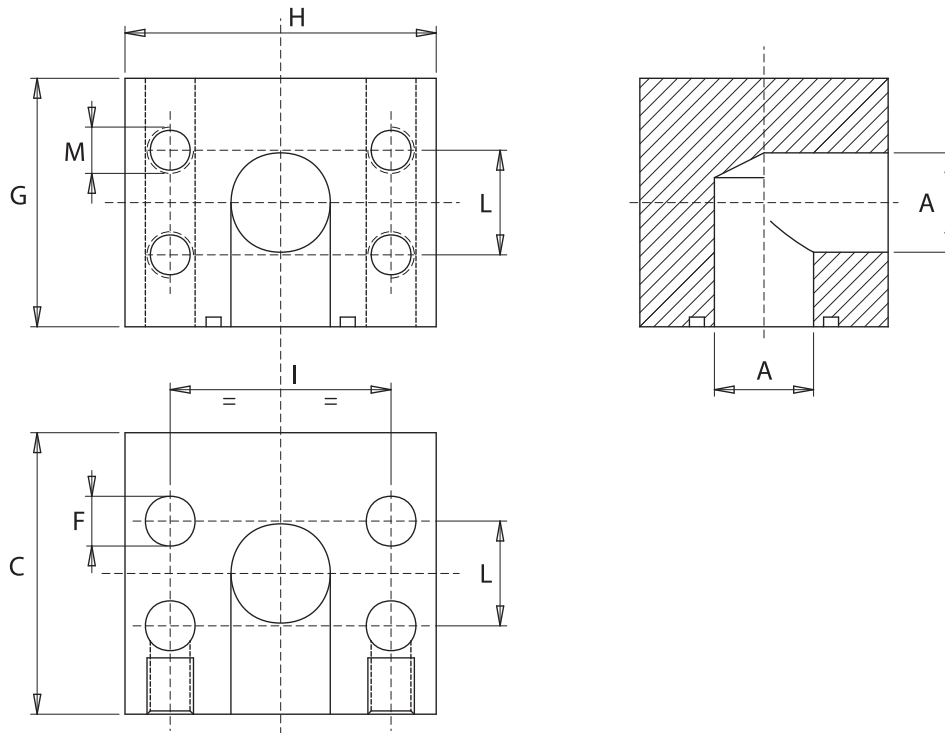

3000 psi

PRESS. MAX bar	TIPO TYPE	SAE	A	C	F	G	H	I	L	M	O-Rings
210	LB 304 114	1 1/4"	31	80	11	80	80	58,72	30,18	M10	4150
210	LB 306 112	1 1/2"	38	94	13,5	94	94	69,85	35,71	M12	4187
210	LB 308 200	2"	50	87	13,5	87	103	77,77	42,88	M12	4225

6000 psi

PRESS. MAX bar	TIPO TYPE	SAE	A	C	F	G	H	I	L	M	O-Rings
420	LB 600 034	3/4"	19	60	11	55	70	50,80	23,80	M10	4100
420	LB 602 100	1"	25	69	13	69	80	57,15	27,76	M12	4131
420	LB 604 114	1 1/4"	30	75	15	75	94	66,68	31,75	M14	4150
420	LB 606 112	1 1/2"	38	89	17	89	106	79,38	36,50	M16	4187
420	LB 608 200	2"	50	116	21	116	135	96,82	44,45	M20	4225

Esempio codice di ordinazione - Ordering example

LB 604 114

L BLOCK

Flangia SAE riduzione 90°
90° SAE reduction BLOCKS

Materiale: Acciaio
Material: Steel

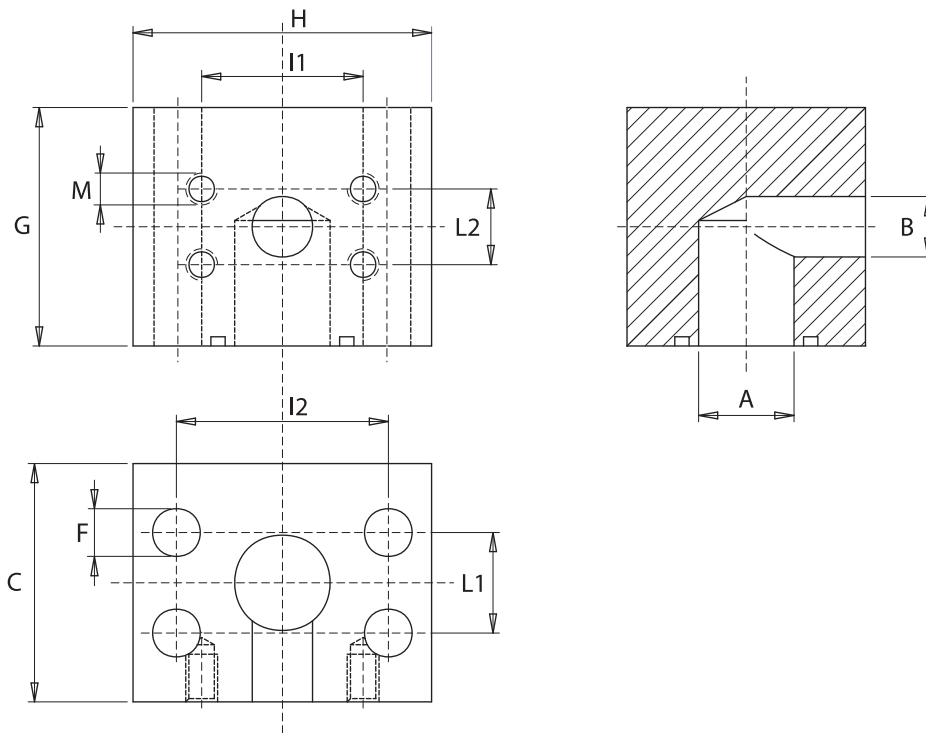

6000 psi

PRESS. MAX bar	TIPO TYPE	SAE	A	B	C	F	G	H	I1	L1	L2	I2	M	O-Rings
420	RB403-402100	1"	25	19	69	13	69	80	50,80	27,76	23,80	57,15	M10	4131
420	RB404-402114	1 1/4"	30	19	75	15	75	94	50,80	31,75	23,80	66,68	M10	4150
420	RB404-403114	1 1/4"	30	25	75	15	75	94	57,15	31,75	27,76	66,68	M12	4150
420	RB405-404112	1 1/2"	38	30	89	17	89	106	66,68	36,50	31,75	79,38	M14	4187
420	RB406-405200	2"	50	38	116	21	116	135	79,38	44,45	36,50	96,82	M16	4225

Esempio codice di ordinazione - Ordering example

RB 403 - 402100

T BLOCK

Flangia SAE - T BLOCK
SAE - T BLOCK flanges

Materiale: Acciaio
Material: Steel

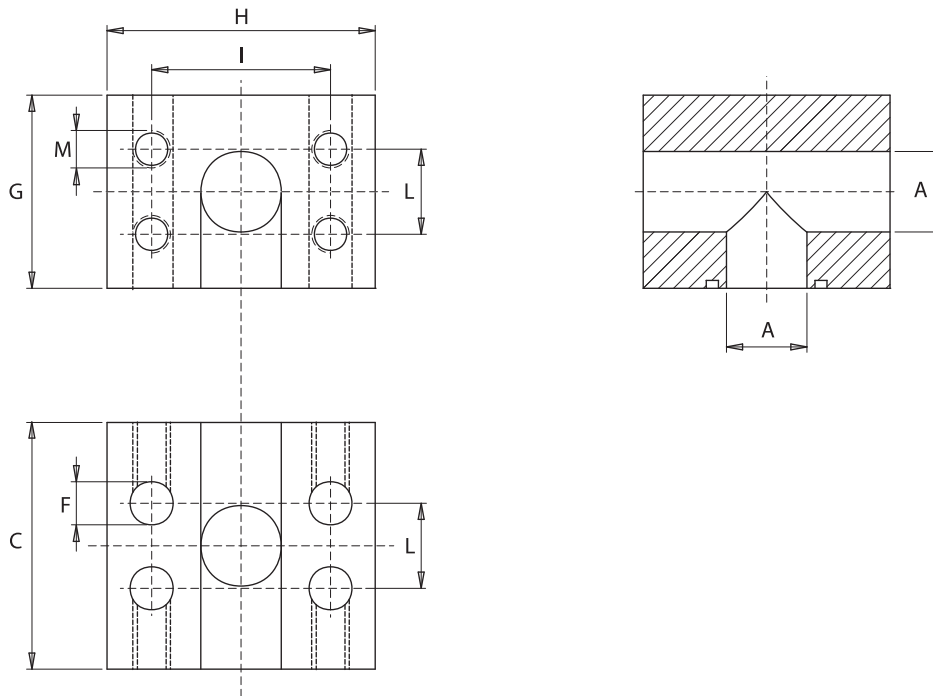

6000 psi

PRESS. MAX bar	TIPO TYPE	SAE	A	C	F	G	H	I	L	M	O-Rings
420	TB600-600034	3/4"	19	70	11	55	70	50,80	23,80	M10	4100
420	TB602-602100	1"	25	80	13	69	80	57,15	27,76	M12	4131
420	TB604-604114	1 1/4"	30	94	15	75	94	66,68	31,75	M14	4150
420	TB606-606112	1 1/2"	38	106	17	100	106	79,38	36,50	M16	4187
420	TB608-608200	2"	50	140	21	116	135	96,82	44,45	M20	4225

Esempio codice di ordinazione - Ordering example

TB 602 - 602100

T BLOCK

Poichè HANSA-TMP offre una gamma di prodotti molto estesa ed alcuni di questi vengono impiegati per più tipi di applicazioni, le informazioni riportate possono riferirsi solo a determinate situazioni.

Se nel catalogo non sono riportati tutti i dati necessari, si prega di contattarci. Al fine di poter fornire una risposta esauriente potrà rendersi necessaria la richiesta di dati specifici riguardanti l'applicazione in questione.

Questo catalogo, pur essendo stato approntato con particolare riguardo alla precisione dei dati riportati, non consiste parte di alcun contratto espresso o implicito.

I dati di questo catalogo si riferiscono ai prodotti standard. La politica di HANSA-TMP consiste nel continuo sviluppo dei suoi prodotti. Per questo motivo ci riserviamo il diritto di modificarne le specifiche, quando necessario, e senza informazione preventiva.

As HANSA-TMP has a very extensive range of products and some products have a variety of applications, the information supplied may often only apply to specific situations.

*If the catalogue does not supply all the information required, please contact HANSA-TMP.
In order to provide a comprehensive reply to queries we may require specific data regarding the proposed application.*

Whilst every reasonable endeavour has been made to ensure accuracy, this publication cannot be considered to represent part of any contract, whether expressed or implied.

The data in this catalogue refer to the standard product. The policy of HANSA-TMP consists of a continuous improvement of its products. It reserves the right to change the specifications of the different products whenever necessary and without giving prior information.



HANSA-TMP S.r.l.

Via M. L. King, 6 – 41122 Modena (ITALY)
Tel.: +39 059 415 711
Fax: +39 059 415 730
E-mail: hansatmp@hansatmp.it
Website: www.hansatmp.it

Certified Company
ISO 9001:2015 – ISO 14001:2015



Share Capital: € 300.000,00
VAT Number: IT01167360369
REA Number: MO-225785