



HANSA-TMP

MANUFACTURING YOUR SUCCESS

HT 16 / M / 3017 / 0621 / E

THE PRODUCTION LINE OF HANSA-TMP

**Fixed Displacement Axial Piston Motor
for Open and Closed Loop System**

**TMF 600
(22 ÷ 100 cm³/rev.)**



CONTENTS

Specification Data.....	4
Motor Dimensions.....	4
Motor Advantages / Port, Shaft and Flange Types.....	5
 Hydraulic Motor TMF 28	
General Information.....	6
Section View.....	7
Specification Data.....	8
Function Diagrams.....	9
Overall Dimensions and Ports SAE-A.....	10
Drive Shafts SAE-A.....	11
Overall Dimensions and Ports SAE-B.....	12
Drive Shafts SAE-B.....	13
Ordering Code.....	14
Valve Options.....	15
 Hydraulic Motor TMF 50	
General Information.....	16
Section View.....	17
Specification Data.....	18
Function Diagrams.....	19
Overall Dimensions and Ports.....	20
Drive Shafts.....	21
Ordering Code.....	22
Valve Options.....	23
 Hydraulic Motor TMF 100	
General Information.....	24
Section View.....	25
Specification Data.....	26
Function Diagrams.....	27
Overall Dimensions and Ports SAE-4C.....	28
Drive Shafts SAE-4C.....	29
Ordering Code.....	30
Valve Options.....	31
Shafts Types and Dimensions.....	32 - 33
Speed Sensors.....	34 - 35
Installation.....	36 - 38
Fluid Viscosity Limits.....	39
Basic and Application Formulas.....	40

Specification Data Motors Type TMF

Intermittent values

Continuous values

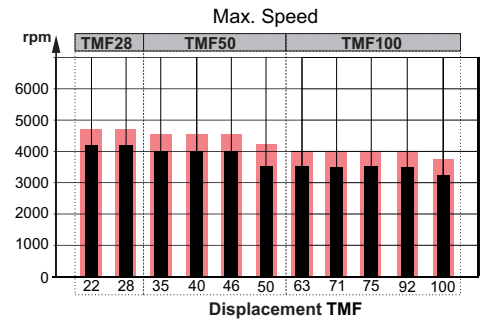
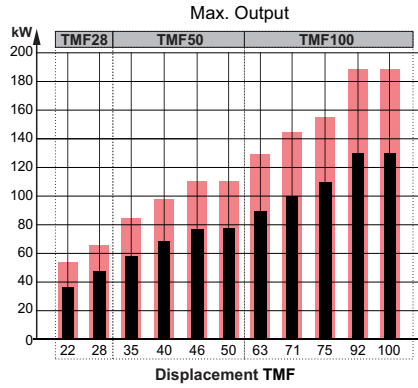
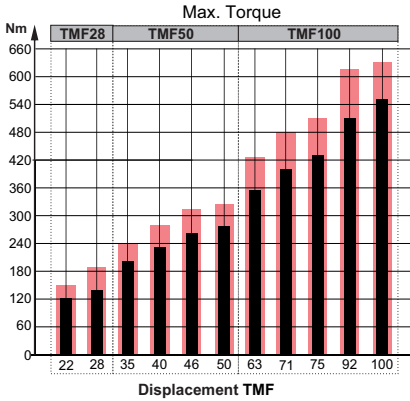

MOTOR DIMENSIONS

The below dimensions are for **comparison only**. The motors can obtain different flanges, shafts and end covers.

TMF28

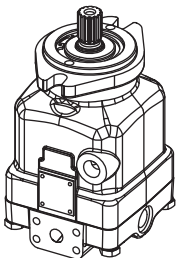
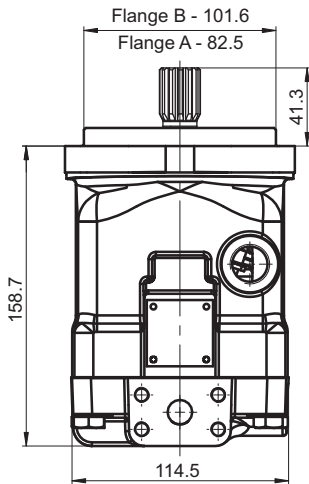

TMF50

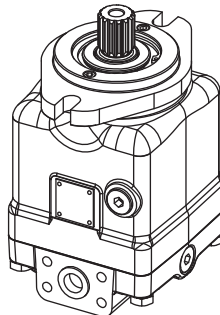
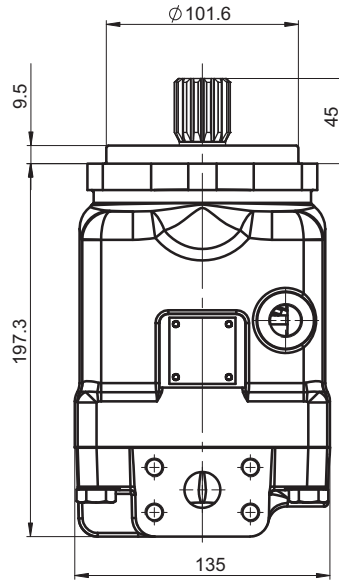

TMF100

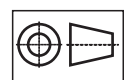
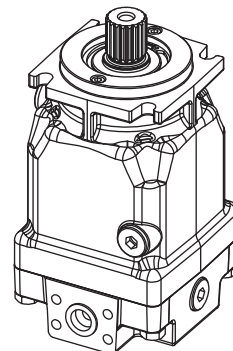
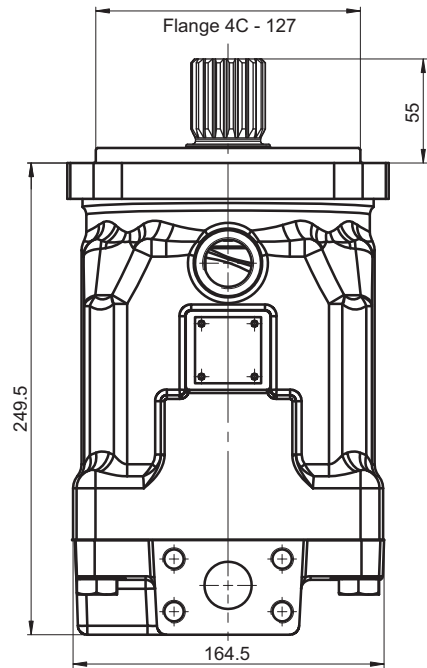

mm

Motor Advantages

1. Hardened shaft ensures long operation life under medium and shock load.
2. Robust radial - axial roller bearing, ensures motor capability for holding radial and axial load.
3. Solid swash plate.
4. Retainer plate, which holds piston group to swash plate without preload forces, ensures high starting torque.
5. Piston shoes with increased diameter ensures long operation life.
6. Improved pistons with increased length and large neck diameter ensure long motor life under high pressure.
7. Brass bushings reduce friction and generated temperature and ensure long operation life under high pressure and high speed of rotation.
8. Hardened steel cylinder block ensures long operation life under medium and shock load.
9. Bimetal distributor plate reduce friction and generated temperature and ensures long operation life under high pressure and high speed of rotation.
10. Needle bearing - ensures motor capability for holding radial load.
11. Solid end cover ensures long operation life under high pressure.

The main advantage of design is that it provides a guaranteed minimal clearance between the elements of the axial piston group without constant preload forces. This advantage reduces the losses from the friction and provides higher starting torque. Using brass bushings and bimetal distributor plate reduced friction and allows higher revolutions of work, less heating of the motor and the oil. At the same time the reduced wearing out provides the longer motor life. Other improvements are in pistons and piston shoes. The pistons are longer with large neck diameter in that way ensure long operation life under high pressure. The piston shoes are with increased diameter ensuring long operation life.

These improvements in design of the TMF motor gain big advantage over the typical swash plate motors. The starting torque is close to the starting torque of the bent axis motors and the total efficiency of design in normal working modes is similar to the bent axis motors. The main advantage of design over the bent axis motors is that the pulsations and vibrations during the operation are much less. Another advantage is that the swash plate motors are more reliable than the bent axis motors.

Port, Shaft and Flange Types

Cross Table - Flange Types

TMF 28	TMF 50	TMF 100	Type of flanges
x			A -2-Bolt, SAE A, SD. 82.5, BC. 106.35, BD 13.5
x	x		B -2-Bolt, SAE B, SD. 101.6, BC. 146, BD. 14.3
		x	4C -4-Bolt flange, SAE C, SD. 127, BC. 161.92, BD. 14.3

Legend

BC (Bolt Circle) - Center point of bolt holes
 BD (Bolt Diameter) - Diameter of bolt holes
 SD (Spigot Diameter) - Center Diameter

Cross Table - Shaft Types

TMF28	TMF50	TMF100	Type of shafts
x	x		SD $\varnothing 21.72$ Spline SAE 13T 16/32 DP, M8-6H thread
x	x		GF $\varnothing 24.9$ Spline SAE 15T 16/32, 3/8-16 UNC-2B thread
	x	x	SK $\varnothing 31.75$ Spline SAE 14T 12/24 DP, M10-6H thread
		x	SP $\varnothing 34.5$ Spline SAE 21T 16/32 DP, M12-6H thread
x	x		CK $\varnothing 22.2$ Straight , M8-6H thread, parallel key 1/4"x1/4"x1" BS46
x			ML $\varnothing 25$ Straight , M8-6H thread, parallel key A8x7x25 DIN6885
x	x		CM $\varnothing 25.4$ Straight , M8-6H thread, parallel key 1/4"x1/4"x1" BS46
	x		CQ $\varnothing 30$ Straight , M8-6H thread, parallel key A8x7x32 DIN6885
	x		CS $\varnothing 32$ Straight , M8-6H thread, parallel key A10x8x45 DIN6885
		x	DU $\varnothing 38.1$ Straight , key 9.528, L38.1, 3/8-16 UNC thread
		x	CV $\varnothing 40$ Straight , M12-6H thread, parallel key A12x8x63 DIN6885

Cross Table - Port Types

PORTS SIZE - THREAD OPTION			
TMF28	TMF50	TMF100	Type of threads
6	2		2xG3/4, drain ports G1/2
		2	2xG1, drain ports G3/4, for rear drain port G1/2

Hydraulic Motors Type TMF 28

Heavy Duty Axial Piston Motors Fixed Displacement

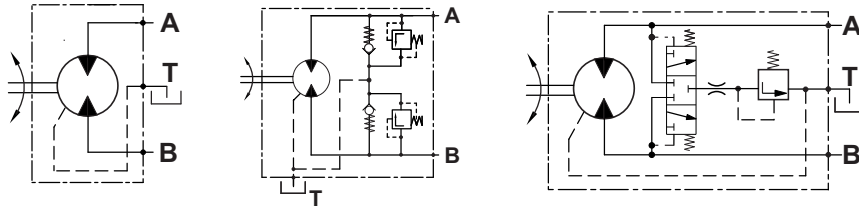

open drain line is always required

APPLICATION

- Agricultural machines
- Road building machines
- Mining machinery
- Food industry machines
- Swing drives
- Hydraulic transmissions
- Vibration machines
- Fan drives
- Special vehicles

OPTIONS

- Swash plate
- Flange options
- Port options
- High pressure ports
- Integrated valves

ADVANTAGES

- High starting torque
- Smooth operation
- Long service life
- High power density

GENERAL

Displacement	cm ³ /rev	22,15÷28.47
Max. Speed	RPM	4200
Max. Torque	Nm	159
Max. Output	kW	48
Max. Pressure Drop	bar	350
Max. Oil Flow	lpm	120
Min. Speed	RPM	500
Fluid		Mineral based- HLP (DIN 51524) or HM (ISO 6743/4)
Temperature Range	°C	-40÷82
Optimal Viscosity Range	mm ² /s	12÷68
Filtration		ISO code 18/16/13 (Min. recommended fluid filtration of 10 micron)

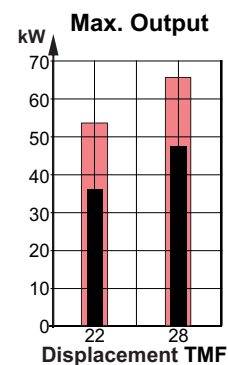
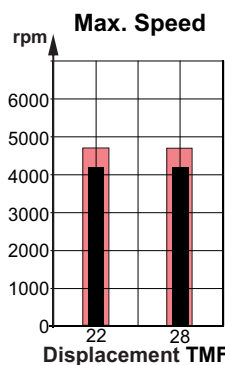
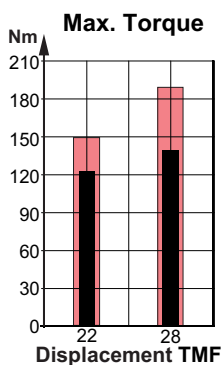

Intermittent values

Continuous values

TMF 28 Motors Series

SECTION VIEW

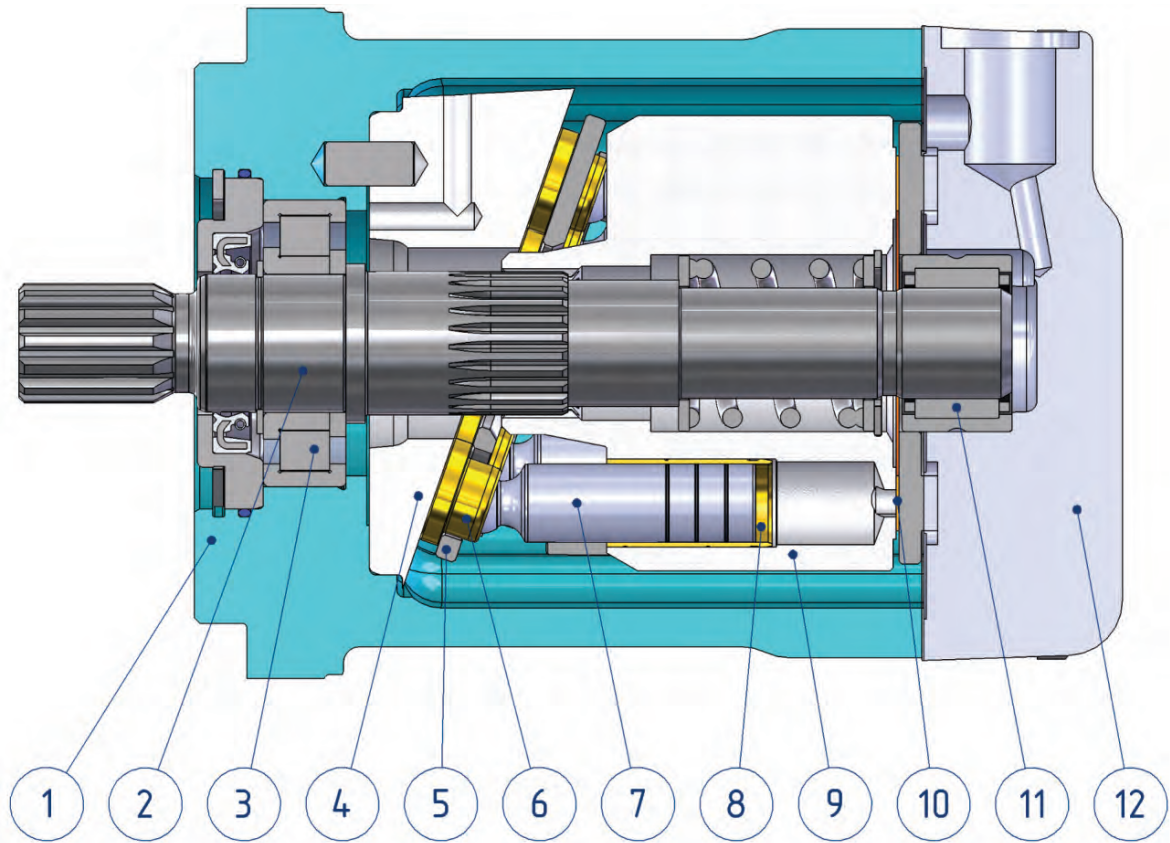

1. Cast iron body.
2. Hardened shaft.
3. Robust radial - axial roller bearing.
4. Solid swash plate.
5. Retainer plate.
6. Improved piston shoes.
7. Improved pistons.
8. Brass bushings.
9. Hardened steel cylinder block.
10. Bimetal distributor.
11. Needle bearing.
12. Solid end cover.

The heavy duty design of the TMF motor gains big advantage over the typical swash plate motors. The starting torque is close to the starting torque of the bent axis motors and the total efficiency of our design in normal working modes is similar to the bent axis motors. The main advantage of our design over the bent axis motors is that the pulsations and vibrations during the operation are much less. Another advantage is that the swash plate motors are more reliable than the bent axis motors.

TMF 28 Motors Series

SPECIFICATION DATA

Type		TMF 22	TMF 28
Displacement cm. ³ /rev.		22.15	28.47
Max. Speed	Cont.	4200	4200
RPM	Int.*	4700	4700
Max. Torque ***	Cont.	123	159
Nm	Int.**	148	190
Output	Cont.	37	48
kW	Int.**	54	70
Max. Pressure	Cont.	350	350
bar	Int.**	420	420
Max. Oil Flow	Cont.	93	120
lpm	Int.*	104	134
Permissible Shaft Load			
max Axial****	N	Fa=1300	
max Radial****	N	Fr=2200	
Min. Speed RPM		500	
Max. Pressure in Drain Line bar		5 open drain line is always required	
Weight kg		11.3	

- * Intermittent speed (flow): for pressure up to 150 bar;
- ** Intermittent load: the permissible values may occur for max. 10% of every minute;
- *** Theoretical torque;
- **** The calculated max values are based on the optimal direction of the forces Fr, Fa and optimal position of the shaft.

1. The recommended output power for continuous operations should not be exceeded.
2. Recommended filtration as per ISO 4406 cleanliness code 18/16/13 or better. This filtration corresponds to SAE AS 4059 8A/7B/7C. Nominal filtration - 10 micron or better.
3. Recommended a premium quality, anti-wear type mineral based hydraulic oil, HLP (DIN 51524) or HM (ISO 6743/4).
4. Recommended oil viscosity - 12...68 cSt or see page 37.
5. Recommended maximum system operating temperature -82°C.
6. To ensure optimum life of the motor, fill it up with fluid prior to load it and run with moderate load and speed for about 10-15 minutes.

TMF 28 Motors Series

FUNCTION DIAGRAMS

The below efficiencies are applied for all displacements.

VOLUMETRIC EFFICIENCIES

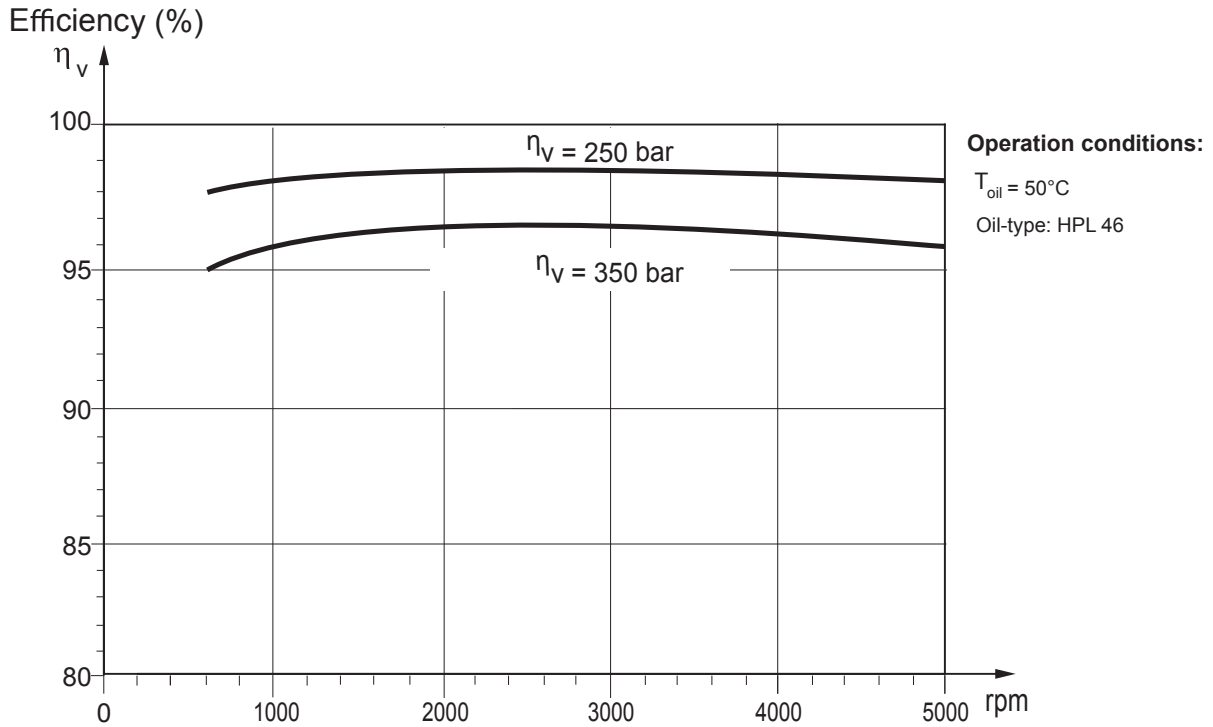

OVERALL EFFICIENCIES

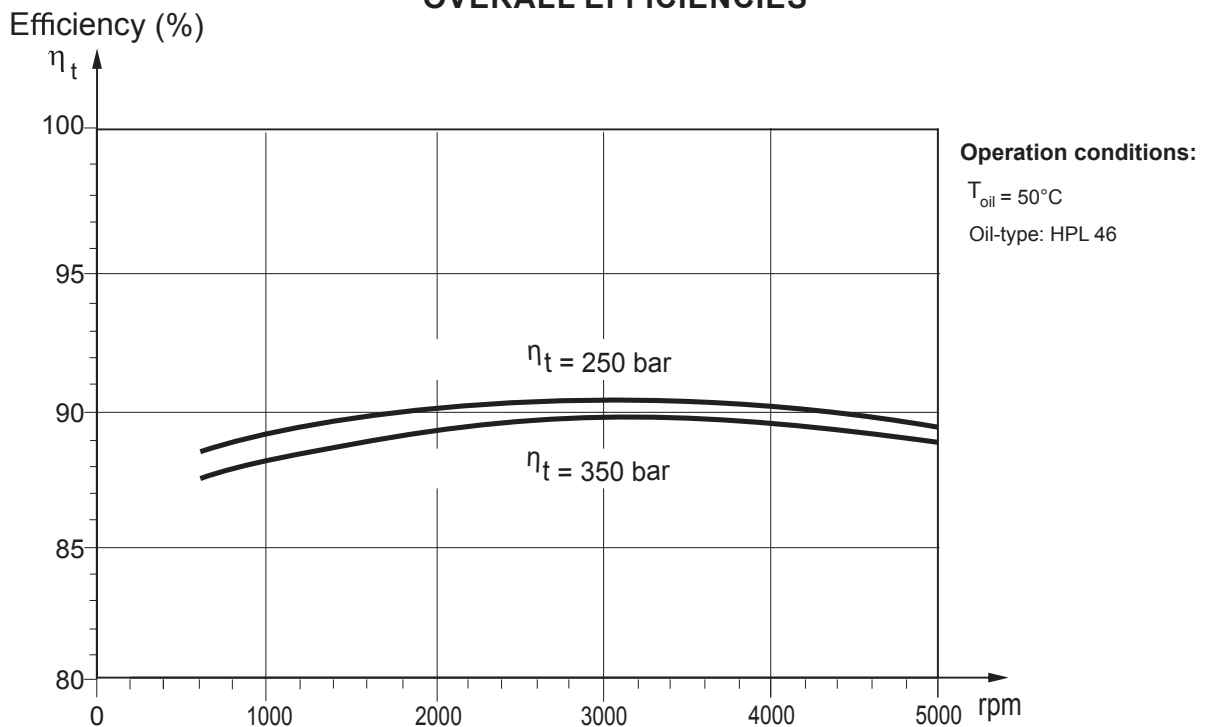

The motor size, pressure, torque, speed of rotation and flow rate required for a specific application can be calculated using the formulas on page 38.

Efficiencies for a particular motor may vary from the shown in the diagram depending on the operating conditions.

TMF 28 Motors Series

**Shafts Mounting
Mounting Flange - Type SAE-A**

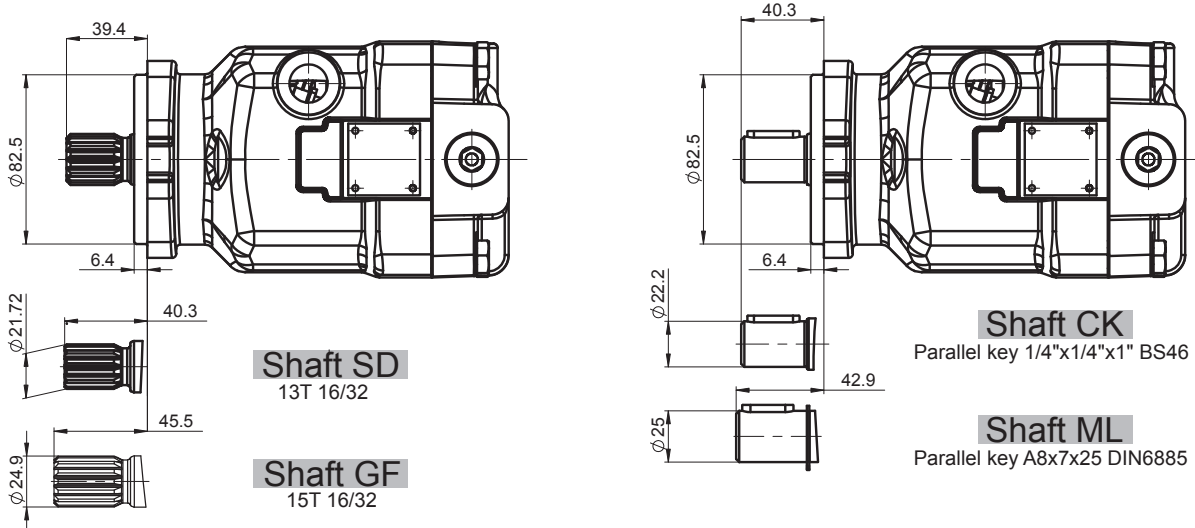

Shaft Dimensions
See Page 32+33

PERMISSIBLE SHAFT LOAD

Permissible shaft load		
max Axial	N	Fa=1300
max Radial	N	Fr=2200

The calculated max values are based on the optimal direction of the forces Fr, Fa and optimal position of the shaft (see page 34).

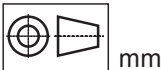

TMF 28 Motors Series

Overall Dimensions and Ports

Side Ports - Default Mounting Flange - Type SAE-B

Side ports

See the port sizes at the bottom of this page

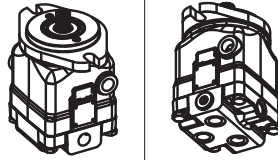
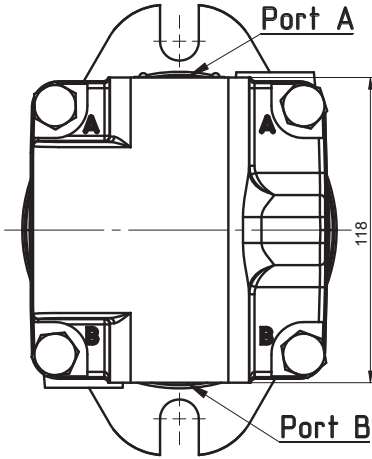

Standard Rotation
Viewed from shaft end
Port A Pressurized - CW
Port B Pressurized - CCW

Rear ports E

See the port sizes at the bottom of this page

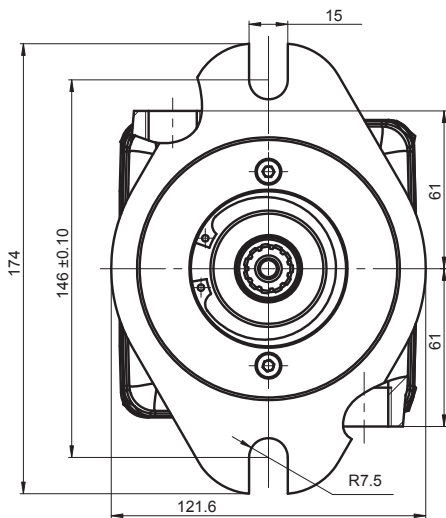
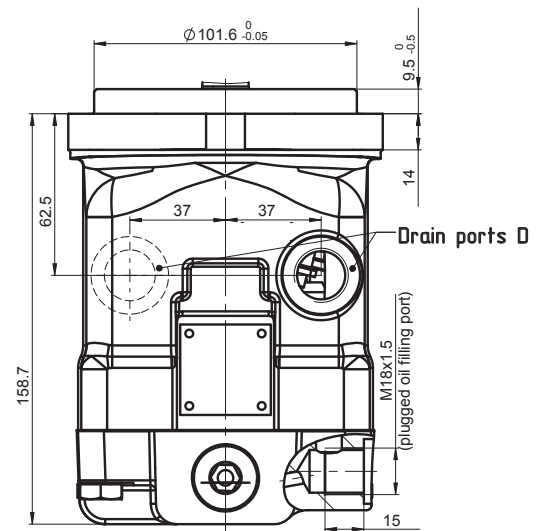
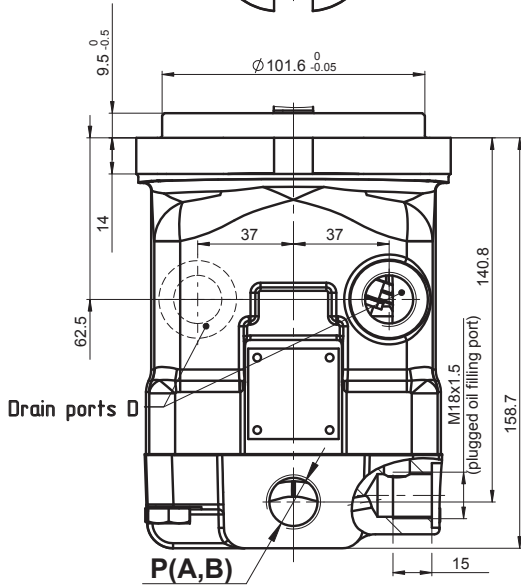
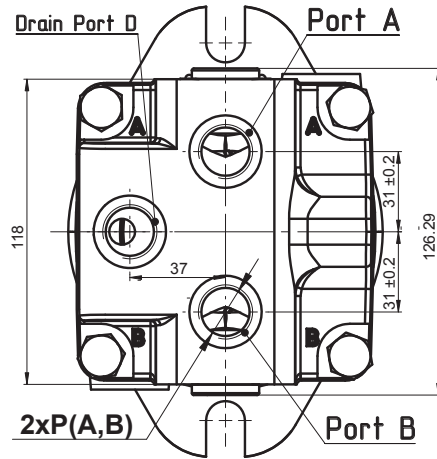

Shaft Mounting
see the next page

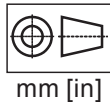

mm [in]

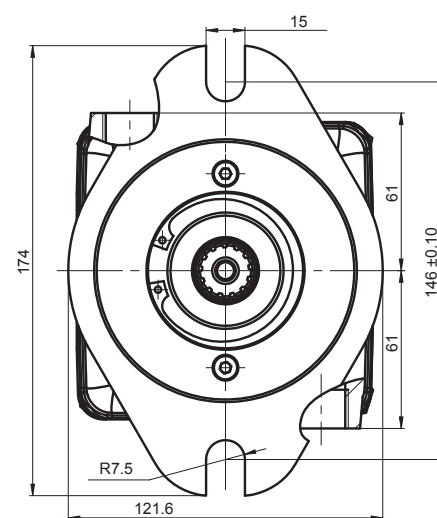

Port Size	
P _(A,B)	2xG 3/4
D	G 1/2

Under development

Port Size	
P _(A,B)	2xG 3/4
D	G 1/2

TMF 28 Motors Series

Shafts Mounting
Mounting Flange - Type SAE-B

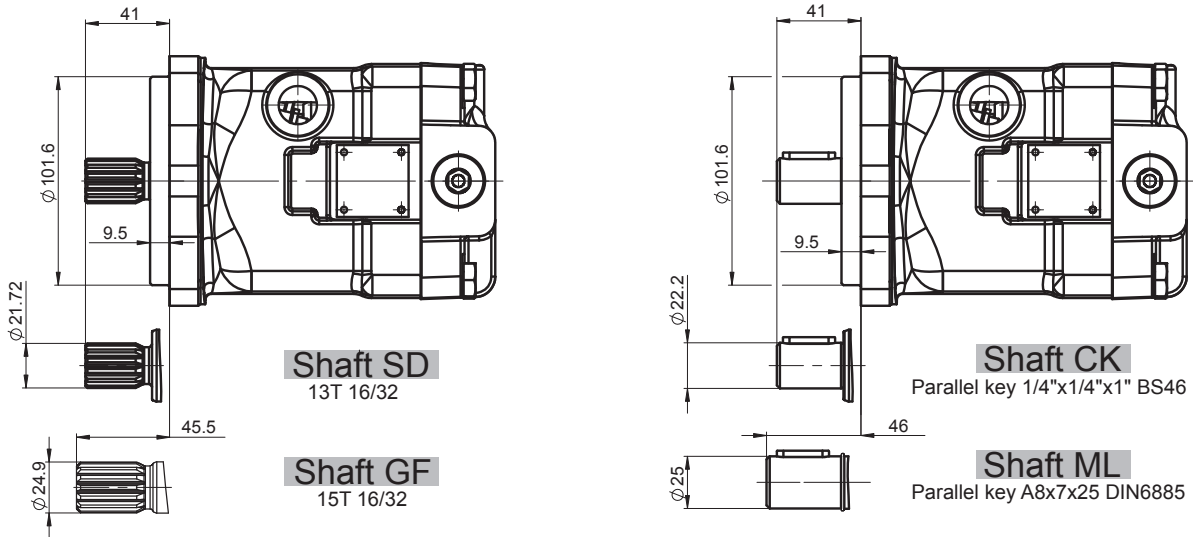

Shaft Dimensions
See Page 32+33

PERMISSIBLE SHAFT LOAD

Permissible shaft load		
max Axial	N	Fa=1300
max Radial	N	Fr=2200

The calculated max values are based on the optimal direction of the forces Fr, Fa and optimal position of the shaft (see page 34).

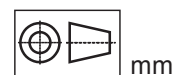

TMF 28 Motors Series

ORDERING CODE

	1	2	3	4	5	6	7	8	9	10	11
T M F											

Pos.1 - Mounting Flange

- A** - 2-Bolt flange, SAE A, spigot diam. 82.5, BC 106.35, Bolt diam. 13.5
- B** - 2-Bolt flange, SAE B, spigot dia. 101.6, BC 146, Bolt dia. 14.3

Pos.2 - Port Type

- omit - Side ports on opposite sides (under development)
- E** - Rear ports

Pos.3 - Displacement Code

- 22** - 22.15 cm.³/rev.
- 28** - 28.47 cm.³/rev.

Pos.4 - Shaft Extensions *

- SD** - ø21.72 Spline SAE 13T 16/32 DP, M8-6H thread
- GF** - ø24.9 Spline SAE 15T 16/32, 3/8-16 UNC-2B thread
- CK** - ø22.2 Straight, M8-6H thread Parallel key 1/4"x1/4"x1" BS46
- ML** - ø25 Straight, M8-6H thread Parallel key A8x7x25 DIN6885

* The permissible output torque for shafts must not be exceeded!

Pos.5 - Improved radial load

- omit - standard bearing
- N** - Improved bearing

Pos.6 - Port Size

- 2** - 2xG1/2, drain ports G1/2
- 6** - 2xG3/4, drain ports G1/2

Pos.7 - Seal, Corrosion Resistant Seal Surface

- omit - NBR seal type material
- V** - FKM seal type material

Pos.8 - Integrated Valves

- See next page for information about valves
- omit - None
- FLU** - Flush valve
- DAR** - Dual anti-cavitation and relief valve (Option DAR are not available for Pos. 2 option E)

Pos.9 - Pressure Setting of Integrated Valves

- omit - None
- x** - For value - see next page

Pos.10 - Flow Setting of Integrated Valves

- omit - None
- Lx** - For value - see next page

Pos.11 - Special Features

- omit - None
- R2S** - Speed sensor two directional

TMF 28 Motors Series

Valve Options

The overall dimensions of the motor with integrated valves could vary compared to the standard motors.

Option DAR

Combined Anti-Cavitation and Relief Valve

- Anti-cavitation check valve is used for applications such as Fan drive control;
- Pressure relief valves prevent excessive pressures in the high pressure loop.

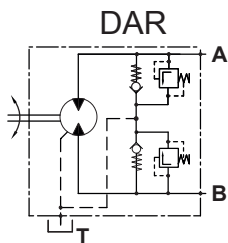

Please, consider the following possible values:

Pos.8

250	300	350
-----	-----	-----

 → pressure

EXAMPLE

TMF B 28 S D 2 D A R 3 5 0

Double Anti-Cavitation and Relief Valve, relief valve setting 350 bar

**Option FLU
FLUSH VALVE**

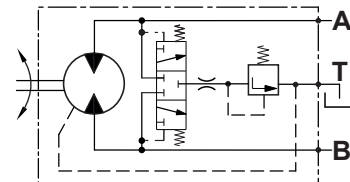

- Mainly used in close loop circuit;
- The valve is a combination between a purge valve and relief valve;
- Flow rate by **default (omit) - 3 ÷ 7 lit/min and charge (opening) pressure 16 bar** with 20 bar feed pressure for close loop circuit;
- For other options, please see Pos.8 and Pos. 9 of ordering code, considering the following possible values:

Pos.8

omit	10
------	----

 → pressure

Pos.9

omit	L3.5	L5.5
------	------	------

 → flow rate

EXAMPLE

TMF B 28 S D 2 F L U flow rate 5±2 lit/min, charge pressure 16 bar

TMF B 28 S D 2 F L U 10 L 5.5 flow rate 5.5±1 lit/min, charge pressure 10 bar

TMF B 28 S D 2 F L U L 3.5 flow rate 3.5±1 lit/min, charge pressure 16 bar

Hydraulic Motors Type TMF 50

Heavy Duty Axial Piston Motors Fixed Displacement

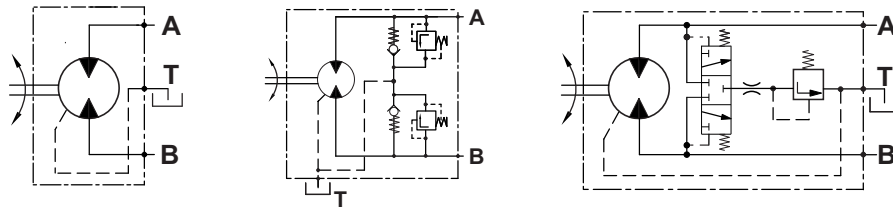

open drain line is always required

APPLICATION

- Agricultural machines
- Road building machines
- Mining machinery
- Food industry machines
- Swing drives
- Hydraulic transmissions
- Vibration machines
- Fan drives
- Special vehicles

OPTIONS

- Swash plate
- Port options
- Shaft options
- High pressure ports
- Integrated valves

ADVANTAGES

- High starting torque
- Smooth operation
- Long service life
- High power density

GENERAL

Displacement	cm ³ /rev	36,16÷49.94
Max. Speed	RPM	4000
Max. Torque	Nm	278
Max. Output	kW	76
Max. Pressure Drop	bar	350
Max. Oil Flow	lpm	180
Min. Speed	RPM	500
Fluid		Mineral based - HLP (DIN 51524) or HM (ISO 6743/4)
Temperature Range	°C	-40÷82
Optimal Viscosity Range	mm ² /s	12÷68
Filtration		ISO code 18/16/13 (Min. recommended fluid filtration of 10 micron)

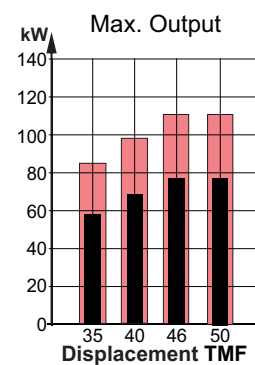
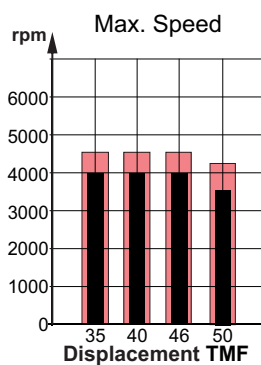
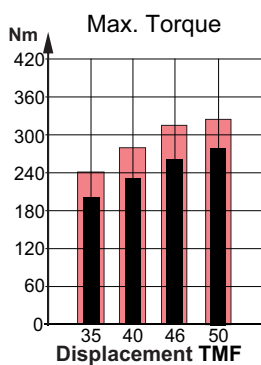

Intermittent values

Continuous values

TMF 50 Motors Series

SECTION VIEW

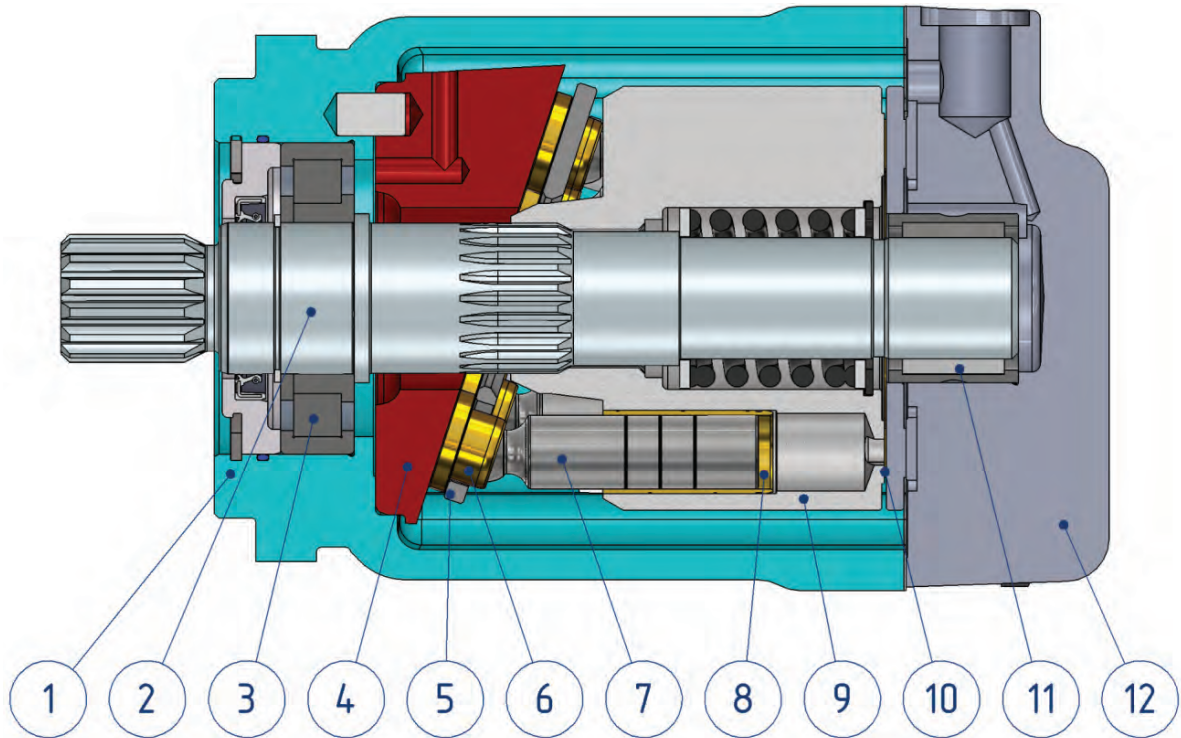

1. Cast iron body.
2. Hardened shaft.
3. Robust radial - axial roller bearing.
4. Solid swash plate.
5. Retainer plate.
6. Improved piston shoes.
7. Improved pistons.
8. Brass bushings.
9. Hardened steel cylinder block.
10. Bimetal distributor.
11. Needle bearing.
12. Solid end cover.

The heavy duty design of the TMF motor gains big advantage over the typical swash plate motors. The starting torque is close to the starting torque of the bent axis motors and the total efficiency of our design in normal working modes is similar to the bent axis motors. The main advantage of our design over the bent axis motors is that the pulsations and vibrations during the operation are much less. Another advantage is that the swash plate motors are more reliable than the bent axis motors.

TMF 50 Motors Series

SPECIFICATION DATA

Type		TMF 35	TMF 40	TMF 46	TMF 50
Displacement cm. ³ /rev.		36.16	41.59	47.13	49.94
Max. Speed RPM	Cont.	4000	4000	4000	3600
	Int.*	4500	4500	4500	4200
Max. Torque *** Nm	Cont.	202	232	263	278
	Int.**	242	278	315	326
Output kW	Cont.	58	67	76	76
	Int.**	84	97	110	110
Max. Pressure bar	Cont.	350	350	350	350
	Int.**	420	420	420	410
Max. Oil Flow lpm	Cont.	145	167	189	180
	Int.*	163	187	212	210
Permissible Shaft Load					
max Axial****	N	Fa=2000			
max Radial****	N	Fr=3600			
Min. Speed RPM		500			
Max. Pressure in Drain Line bar		5 open drain line is always required			
Weight kg		17.8			

- * Intermittent speed (flow): for pressure up to 150 bar;
- ** Intermittent load: the permissible values may occur for max. 10% of every minute;
- *** Theoretical torque;
- **** The calculated max values are based on the optimal direction of the forces Fr, Fa and optimal position of the shaft.

1. The recommended output power for continuous operations should not be exceeded.
2. Recommended filtration as per ISO 4406 cleanliness code 18/16/13 or better. This filtration corresponds to SAE AS 4059 8A/7B/7C. Nominal filtration - 10 micron or better.
3. Recommended a premium quality, anti-wear type mineral based hydraulic oil, HLP (DIN 51524) or HM (ISO 6743/4).
4. Recommended oil viscosity - 12...68 cSt or see page 37.
5. Recommended maximum system operating temperature -82°C.
6. To ensure optimum life of the motor, fill it up with fluid prior to load it and run with moderate load and speed for about 10-15 minutes.

TMF 50 Motors Series

FUNCTION DIAGRAMS

The below efficiencies are applied for all displacements.

VOLUMETRIC EFFICIENCIES

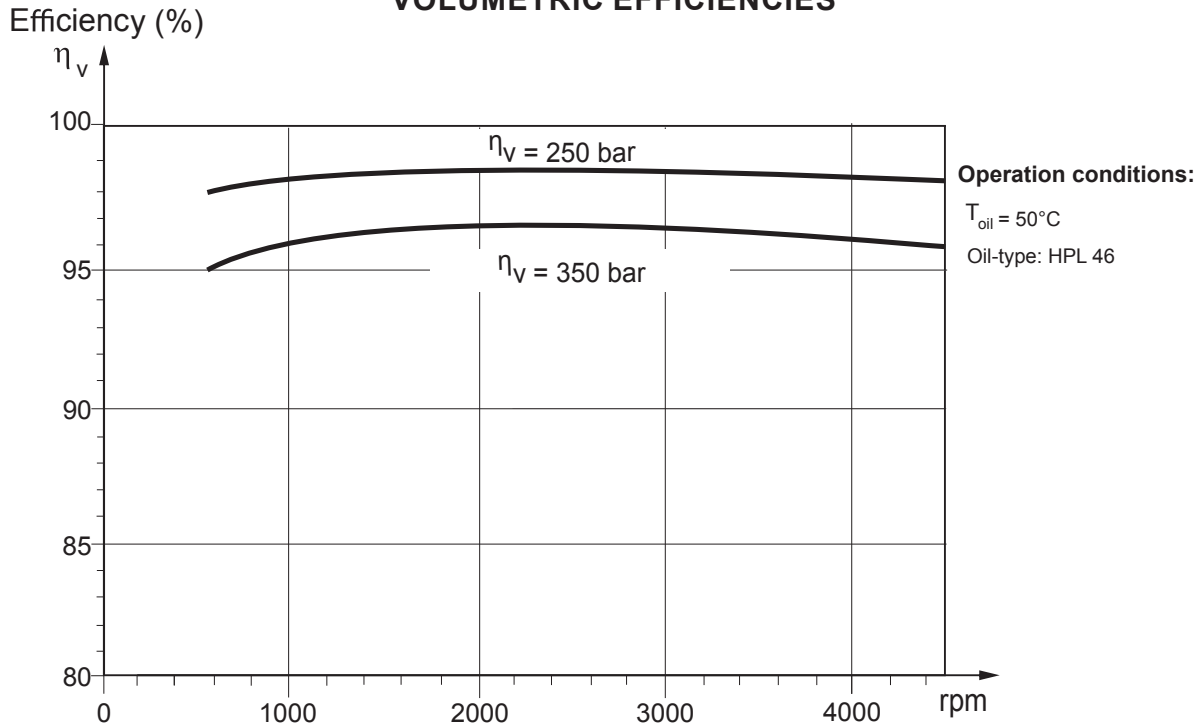

OVERALL EFFICIENCIES

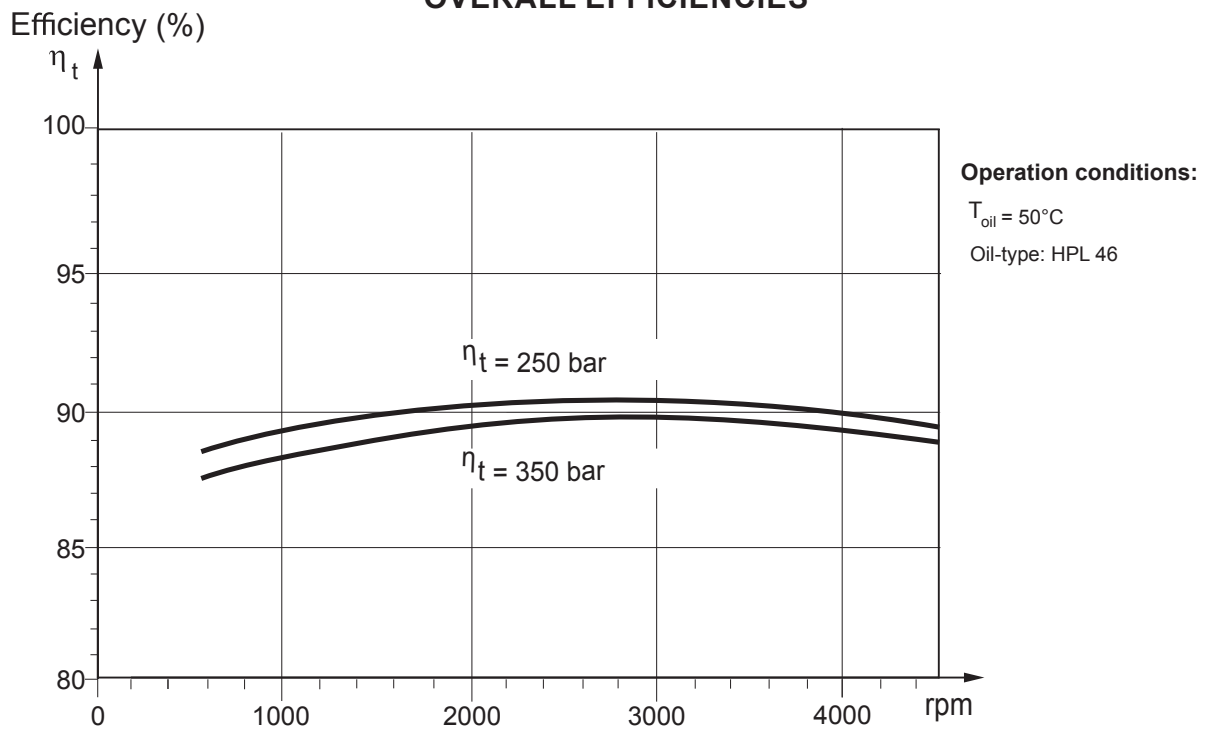

The motor size, pressure, torque, speed of rotation and flow rate required for a specific application can be calculated using the formulas on page 38.

Efficiencies for a particular motor may vary from the shown in the diagram depending on the operating conditions.

TMF 50 Motors Series

Overall Dimensions and Ports

Side ports - Standard

See the port sizes at the bottom of this page

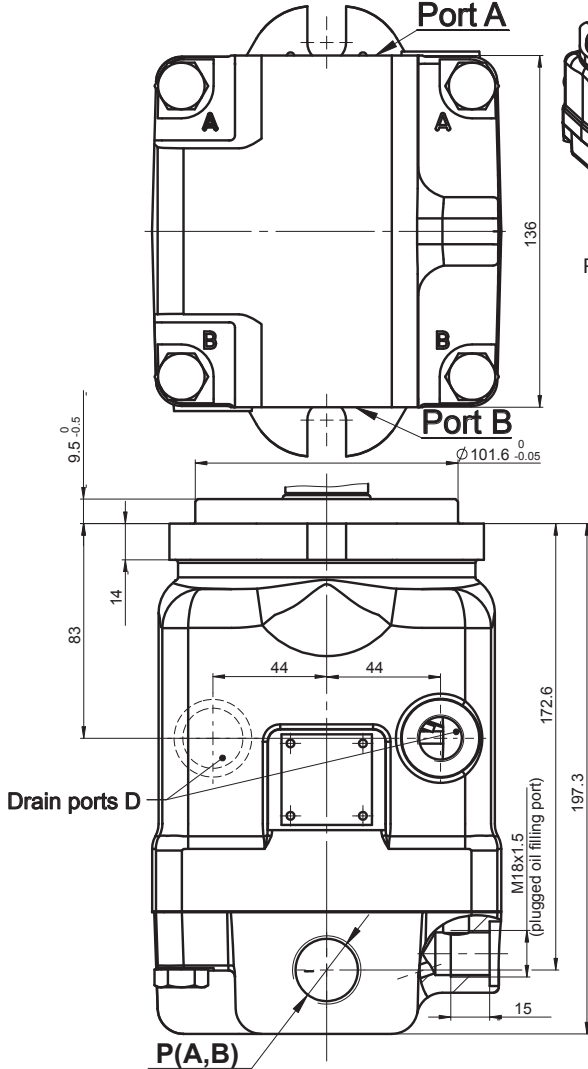

Standard Rotation
Viewed from shaft end
Port A Pressurized - CW
Port B Pressurized - CCW

Rear ports - Type E

See the port sizes at the bottom of this page

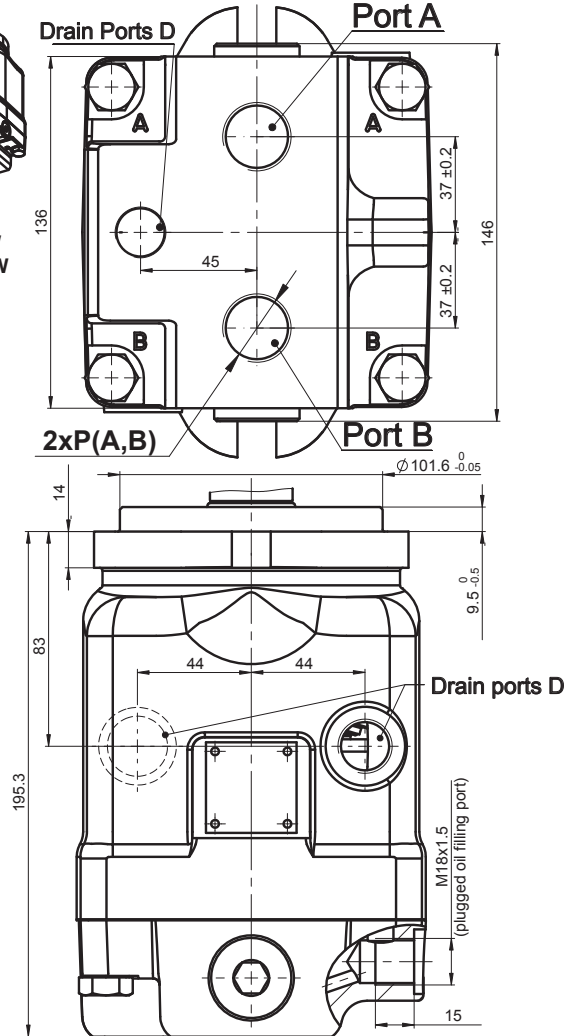

Shaft Mounting
see the next page

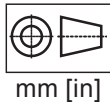

Port Size	
P _(A,B)	2xG 3/4
D	G 1/2

Port Size	
P _(A,B)	2xG 3/4
D	G 1/2

TMF 50 Motors Series

Shafts Mounting

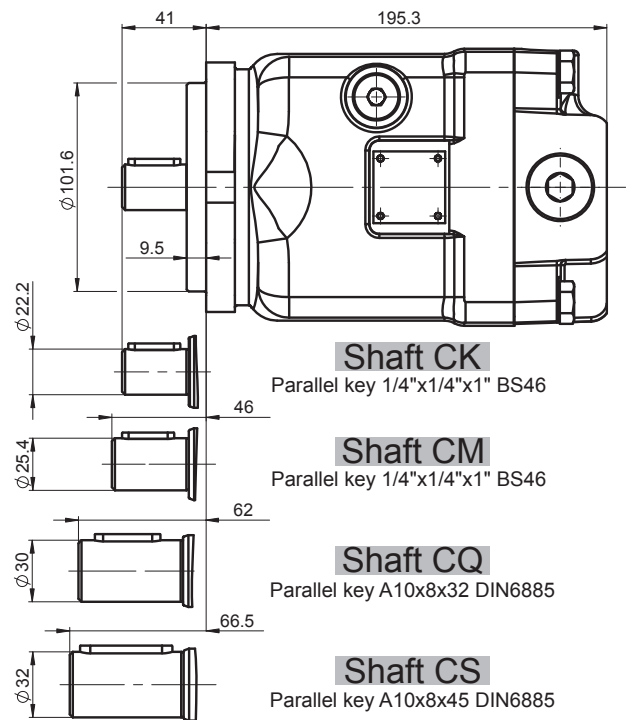
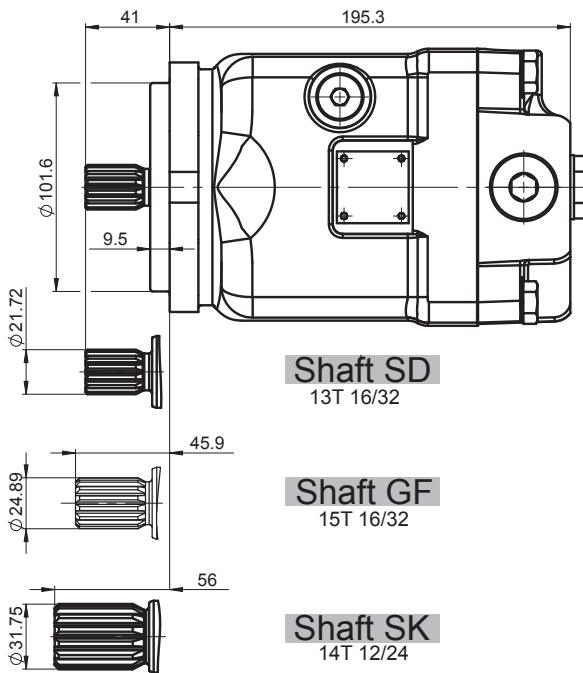

Shaft Dimensions
See Page 32+33

PERMISSIBLE SHAFT LOAD

Permissible shaft load		
max Axial	N	Fa=2000
max Radial	N	Fr=3600

The calculated max values are based on the optimal direction of the forces Fr, Fa and optimal position of the shaft (see page 34).

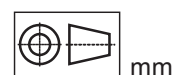

TMF 50 Motors Series

ORDERING CODE

	1	2	3	4	5	6	7	8	9	10
T M F										

Pos.1 - Mounting Flange

B - SAE B - 2-Bolt flange
spigot diam. 101.6 mm - BC 146 mm

Pos.2 - Port Type

omit - Side ports on opposite sides
E - Rear ports

Pos.3 - Displacement Code

35 - 36.16 cm.³/rev.
40 - 41.59 cm.³/rev.
46 - 47.13 cm.³/rev.
50 - 49.94 cm.³/rev.

Pos.4 - Shaft Extensions*

SD - ø21.72 Spline SAE 13T 16/32 DP, M8
GF - ø24.9 Spline SAE 15T 16/32, 3/8-16 UNC-2B
SK - ø31.75 Spline SAE 14T 12/24 DP, M10
CK - ø22.2 Straight, M8-6H thread
Parallel key 1/4"x1/4"x1" BS46
CM - ø25.4 Straight, M8-6H thread
Parallel key 1/4"x1/4"x1" BS46
CQ - ø30 Straight, M8-6H thread
Parallel key A8x7x32 DIN6885
CS - ø32 Straight, M8-6H thread
Parallel key A10x8x45 DIN6885

* The permissible output torque for shafts must not be exceeded!

Pos.5 - Port Size

2 - 2xG3/4, drain ports G1/2

Pos.6 - Seal, Corrosion Resistant Seal Surface

omit - NBR seal type material
V - FKM seal type material

Pos.7 - Integrated Valves

See next page for information about valves
omit - None
FLU - Flush valve
DAR - Dual anti-cavitation and relief valve
(Option DAR are not available for Pos. 2 option E)

Pos.8 - Pressure Setting of Integrated Valves

omit - None
x - For value - see next page

Pos.9 - Flow Setting of Integrated Valves

omit - None
Lx - For value - see next page

Pos.10 - Special Features

omit - None
R2S - Speed sensor two directional

TMF 50 Motors Series

Valve Options

The overall dimensions of the motor with integrated valves could vary compared to the standard motors.

Option DAR

Combined Anti-Cavitation and Relief Valve

- Anti-cavitation check valve is used for applications such as Fan drive control;
- Pressure relief valves prevent excessive pressures in the high pressure loop.

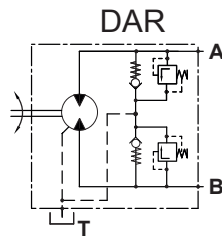

Please, consider the following possible values:

Pos.8

250	300	350
-----	-----	-----

 → pressure

EXAMPLE

TMF B 4 6 S H 2 D A R 3 5 0

Double Anti-Cavitation and Relief Valve, relief valve setting 350 bar

**Option FLU
FLUSH VALVE**

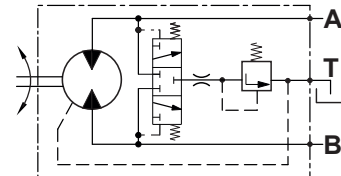

- Mainly used in close loop circuit;
- The valve is a combination between a purge valve and relief valve;
- Flow rate by **default (omit) - 4 ÷ 8 lit/min and charge (opening) pressure 16 bar** with 20 bar feed pressure for close loop circuit;
- For other options, please see Pos.8 and Pos. 9 of ordering code, considering the following possible values:

Pos.8

omit	10
------	----

 → pressure

Pos.9

omit	L3.5	L5.5
------	------	------

 → flow rate

EXAMPLE

TMF B 4 6 S H 2 F L U flow rate 6±2 lit/min, charge pressure 16 bar

TMF B 4 6 S H 2 F L U 1 0 L 5 . 5 flow rate 5.5±1 lit/min, charge pressure 10 bar

TMF B 4 6 S H 2 F L U L 3 . 5 flow rate 3.5±1 lit/min, charge pressure 16 bar

Hydraulic Motors Type TMF 100

Heavy Duty Axial Piston Motors Fixed Displacement

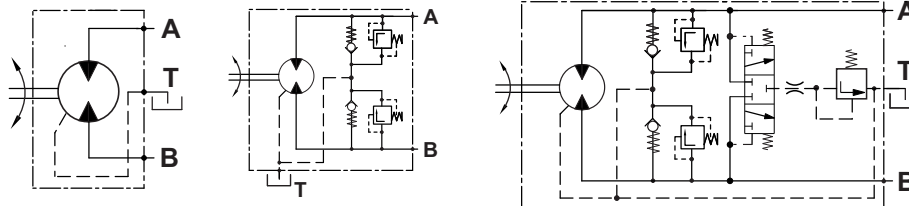

open drain line is always required

APPLICATION

- Agricultural machines
- Road building machines
- Mining machinery
- Food industry machines
- Swing drives
- Hydraulic transmissions
- Vibration machines
- Fan drives
- Special vehicles

OPTIONS

- Swash plate
- Flange options
- Port options
- High pressure ports
- Integrated valves

ADVANTAGES

- High starting torque
- Smooth operation
- Long service life
- High power density

GENERAL

Displacement	cm ³ /rev	63.58÷98.75
Max. Speed	RPM	3500
Max. Torque	Nm	550
Max. Output	kW	130
Max. Pressure Drop	bar	350
Max. Oil Flow	lpm	326
Min. Speed	RPM	500
Fluid		Mineral based- HLP (DIN 51524) or HM (ISO 6743/4)
Temperature Range	°C	-40÷82
Optimal Viscosity Range	mm ² /s	12÷68
Filtration		ISO code 18/16/13 (Min. recommended fluid filtration of 10 micron)

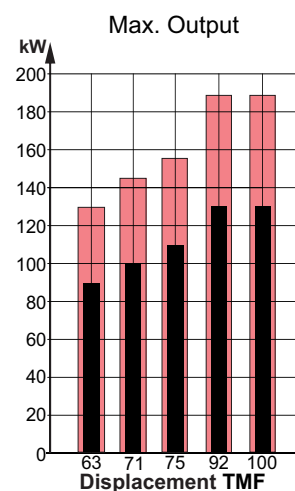
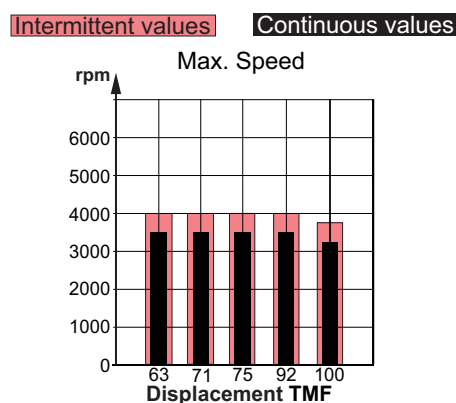
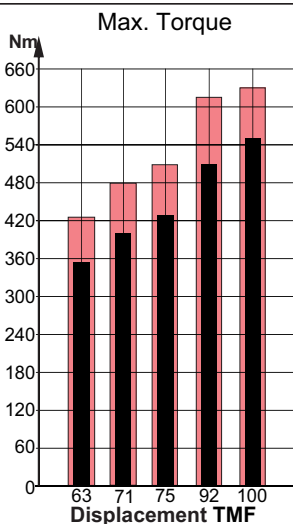

TMF 100 Motors Series

SECTION VIEW

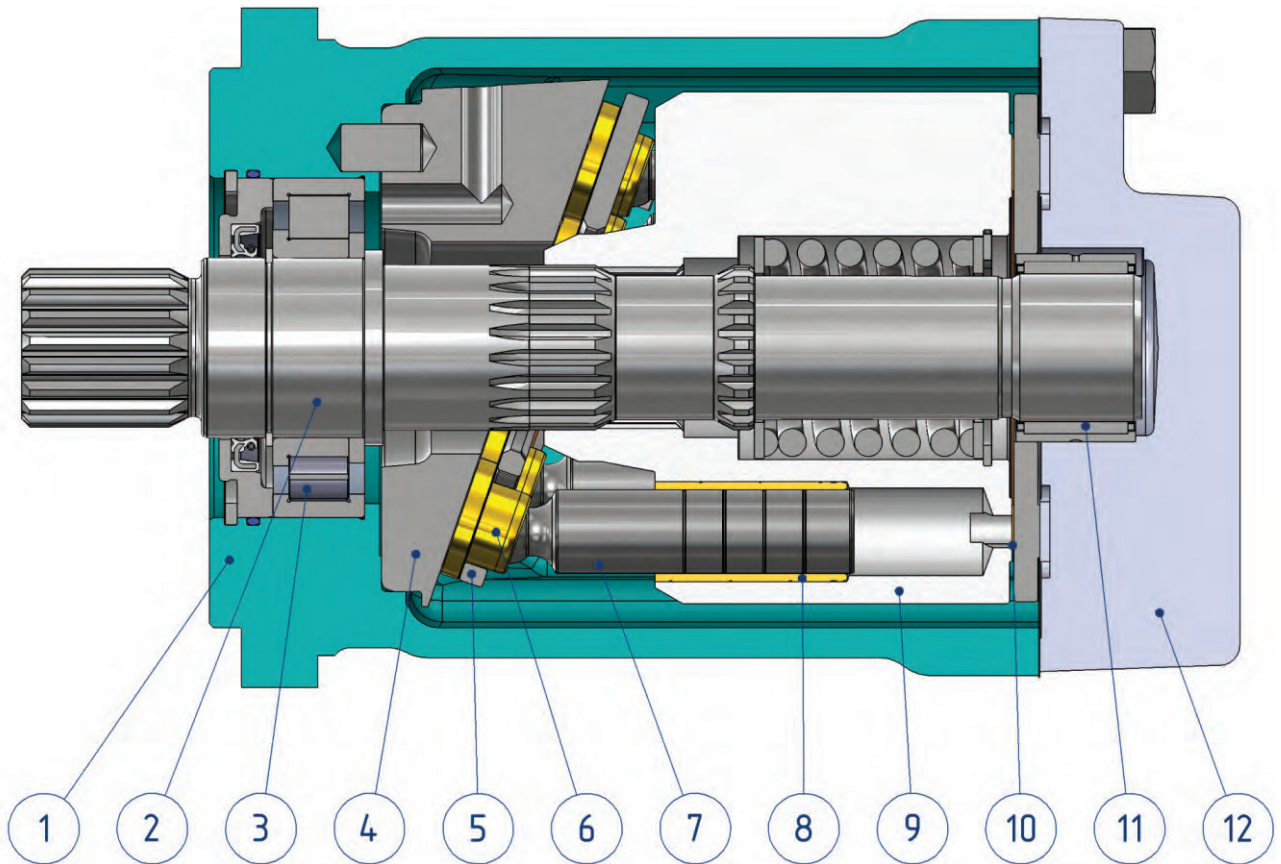

- 1. Cast iron body
- 2. Hardened shaft
- 3. Robust radial - axial roller bearing
- 4. Solid swash plate
- 5. Retainer plate
- 6. Improved piston shoes
- 7. Improved pistons
- 8. Brass bushings
- 9. Hardened steel cylinder block
- 10. Bimetal distributor
- 11. Needle bearing
- 12. Solid end cover

The heavy duty design of TMF motor gains big advantage over the typical swash plate motors. The starting torque is close to the starting torque of the bent axis motors and the total efficiency of our design in normal working modes is similar to the bent axis motors. The main advantage of our design over the bent axis motors is that the pulsations and vibrations during the operation are much less. Another advantage is that the swash plate motors are more reliable than the bent axis motors.

TMF 100 Motors Series

SPECIFICATION DATA

Type		TMF 63	TMF 71	TMF 75	TMF 92	TMF 100
Displacement cm. ³ /rev.		63.58	71.5	76.84	93.18	98.75
Max. Speed [RPM]	Cont.	3500	3500	3500	3500	3240
	Int.*	4000	4000	4000	4000	3750
Max. Torque *** Nm	Cont.	354	398	428	514	550
	Int.**	425	478	514	616	645
Output kW	Cont.	89	100	108	130	130
	Int.**	129	145	156	188	188
Max. Pressure bar	Cont.	350	350	350	350	350
	Int.**	420	420	420	420	410
Max. Oil Flow lpm	Cont.	223	250	269	326	320
	Int.*	255	286	308	373	370
Permissible Shaft Load						
max Axial**** N		Fa=2500				
max Radial**** N		Fr=4500				
Min. Speed [RPM]		500				
Max. Pressure in Drain Line bar		5 open drain line is always required				
Weight kg		32.5				

* Intermittent speed (flow) is for pressure up to 150 bar.

** Intermittent load: the permissible values may occur for max. 10% of every minute.

*** Theoretical torque

**** The calculated max values are based on the optimal direction of the forces Fr, Fa and optimal position of the shaft.

1. The recommended output power for continuous operations should not be exceeded.
2. Recommended filtration as per ISO 4406 cleanliness code 18/16/13 or better. This filtration corresponds to SAE AS 4059 8A/7B/7C. Nominal filtration - 10 micron or better.
3. Recommended using of a premium quality, anti-wear type mineral based hydraulic oil, HLP(DIN51524) or HM(ISO6743/4).
4. Recommended oil viscosity - 15...30 cSt or see page 37.
5. Recommended maximum system operating temperature 80°C.
6. To ensure optimum life of the motor, fill it up with fluid prior to load it and run with moderate load and speed for about 10-15 minutes.

FUNCTION DIAGRAMS

The below efficiencies are applied for all displacements.

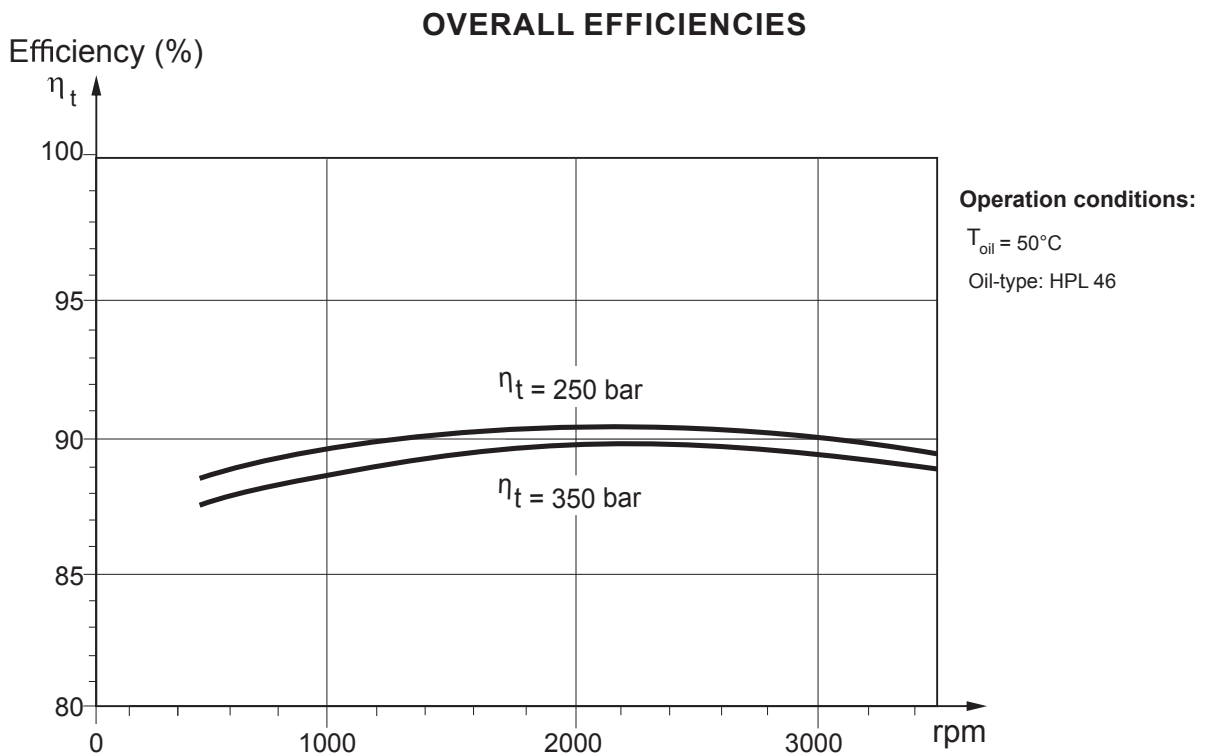
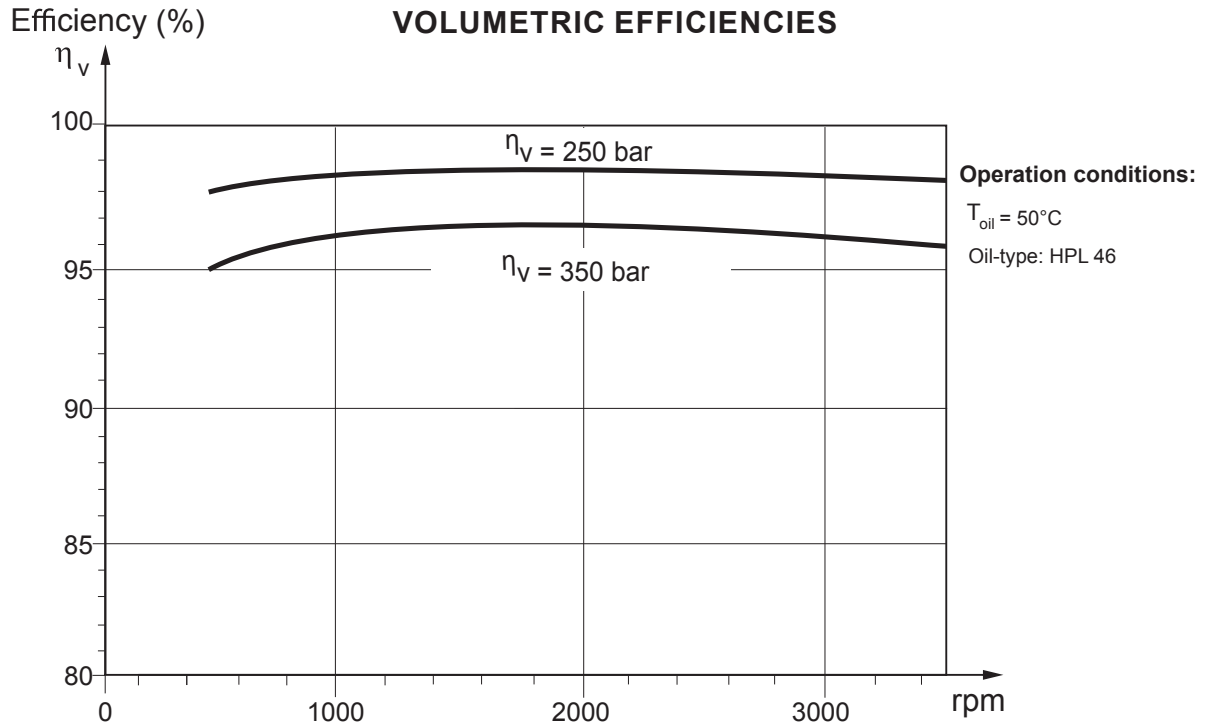

The motor size, pressure, torque, speed of rotation and flow rate required for a specific application can be calculated using the formulas on page 38.

Efficiencies for a particular motor may vary from the shown in the diagram depending on the operating conditions.

TMF 100 Motors Series

**Shafts Mounting
Flange - Type SAE-4C**

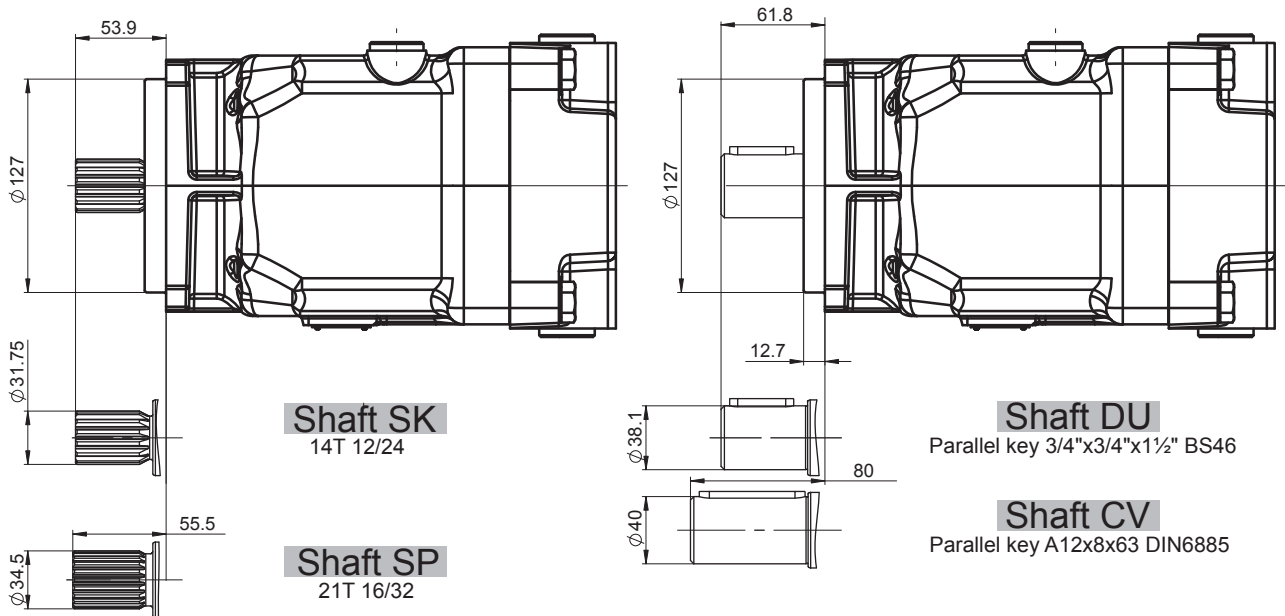

Shaft Dimensions
See Page 32+33

PERMISSIBLE SHAFT LOAD

Permissible shaft load		
max Axial	N	Fa=2500
max Radial	N	Fr=4500

The calculated max values are based on the optimal direction of the forces Fr, Fa and optimal position of the shaft (see page 34).

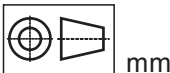

TMF 100 Motors Series

ORDERING CODE

	1	2	3	4	5	6	7	8	9	10
TMF										

Pos.1 - Mounting Flange

- 4C** - SAE C - 4-Bolt flange
spigot diam. 127 mm - BC 161.92 mm

Pos.2 - Port Type

- omit - Side ports on opposite sides
E - Rear ports

Pos.3 - Displacement Code

- 63** - 63.58 cm.³/rev.
71 - 71.5 cm.³/rev.
75 - 76.84 cm.³/rev.
92 - 93.18 cm.³/rev.
100 - 98.75 cm.³/rev.

Pos.4 - Shaft Extensions**

- SK** - ø31.75 Spline SAE 14T 12/24 DP, M10
SP - ø34.5 Spline SAE 21T 16/32 DP, M12
DU - ø38.1 Straight, key 9.528
L38.1, 3/8-16 UNC thread
CV - ø40 Straight, M12-6H thread
Parallel key A12x8x63 DIN6885

** The permissible output torque for shafts
must not be exceeded!

Pos.5 - Ports

- 2** - 2xG1, drain G3/4, for rear drain ports G1/2

Pos.6 - Seal, Corrosion Resistant Seal Surface

- omit - NBR seal type material
V - FKM seal type material

Pos.7 - Integrated Valves

- See next page for information about valves
omit - None
FLU - Flush valve
DAR - Dual anti-cavitation and relief valve

Pos.8 - Pressure Setting of Integrated Valves

- omit - None
x - For value - see next page

Pos.9 - Flow Setting of Integrated Valves

- omit - None
Lx - For value - see next page

Pos.10 - Special Features

- omit - None
R2S - Speed sensor two directional

TMF 100 Motors Series

Valve Options

The overall dimensions of the motor with integrated valves could vary compared to the standard motors.

Option DAR

Combined Anti-Cavitation and Relief Valve

- Anti-cavitation check valve is used for applications such as Fan drive control;
- Pressure relief valves prevent excessive pressures in the high pressure loop.

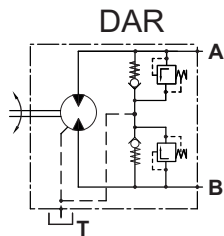

Please, consider the following possible values:

Pos.8

250	300	350
-----	-----	-----

 → pressure

EXAMPLE

TMF4C100ST2DAR350

Double Anti-Cavitation and Relief Valve, relief valve setting 350 bar

**Option FLU
FLUSH VALVE**

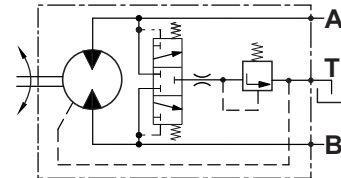

- Mainly used in close loop circuit;
- The valve is a combination between a purge valve and relief valve;
- Flow rate by **default (omit) - 5 ÷ 9 lit/min and charge (opening) pressure 16 bar** with 20 bar feed pressure for close loop circuit;
- For other options, please see Pos.8 and Pos. 9 of ordering code, considering the following possible values:

Pos.8

omit	10
------	----

 → pressure

Pos.9

omit	L5.5	L9
------	------	----

 → flow rate

EXAMPLE

TMF4C100ST2FLU flow rate 7±2 lit/min, charge pressure 16 bar

TMF4C100ST2FLU10L5.5 flow rate 5.5±1 lit/min, charge pressure 10 bar

TMF4C100ST2FLUL9 flow rate 9±1 lit/min, charge pressure 16 bar

Shaft Types and Dimensions

SD

∅ 21.72 SAE-B M8-6H thread
13T 16/32 DP splined ANSI B92.1-1970
 Max. torque 220 Nm

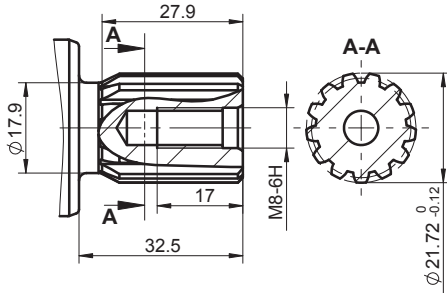

GF

∅ 24.89 SAE-BB 3/8-16 UNC-2B thread
15T 16/32 DP splined ANSI B92.1-1970
 Max. torque 360 Nm

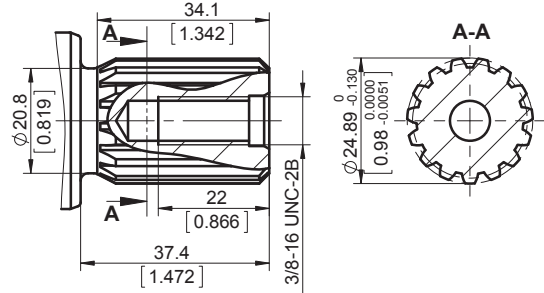

SK

∅ 75.13 SAE-C M10-6H thread
14T 12/24 DP splined ANSI B92.1-1970
 Max. torque 600 Nm

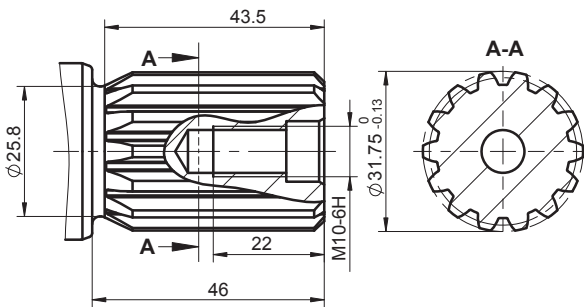

SP

∅ 34.5 SAE-C M12-6H thread
21T 16/32 DP splined ANSI B92.1-1970
 Max. torque 1085 Nm

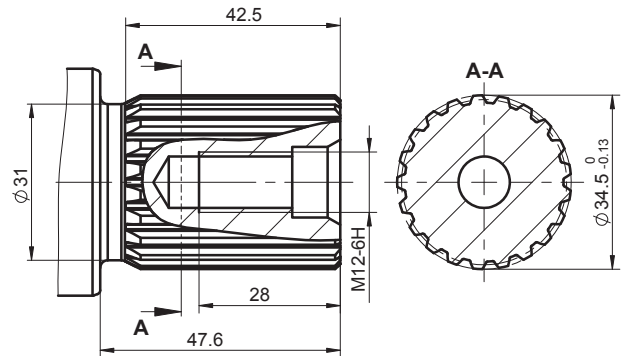

CK

∅ 22.2 SAE-B straight M8-6H thread
 Parallel key **1/4"x1/4"x1"** BS46
 Max. torque 180 Nm

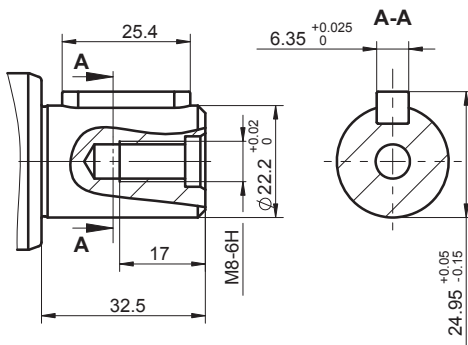

ML

∅ 25 straight M8-6H thread
 Parallel key **A8x7x25** DIN6885
 Max. torque 250 Nm

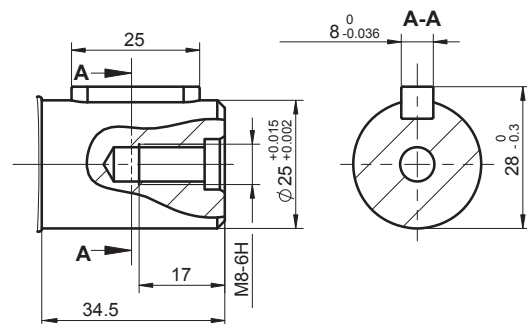

The required max. torque must not be exceeded

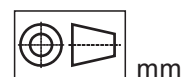

Shaft Types and Dimensions

CM

∅ 25.4 SAE-BB straight M8-6H thread
Parallel key **1/4"x1/4"x1"** BS46
Max. torque 250 Nm

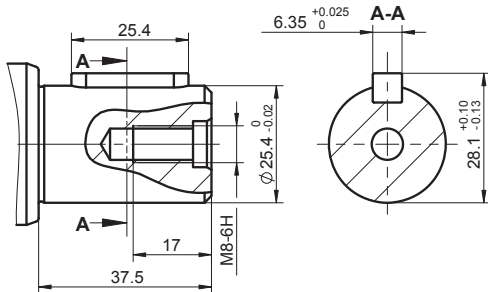

CQ

∅ 30 straight M8-6H thread
Parallel key **A8x7x32** DIN6885
Max. torque 300 Nm

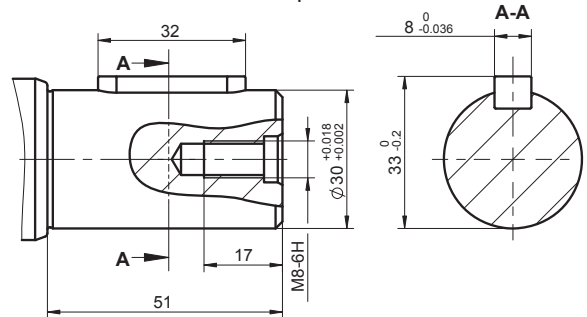

CS

∅ 32 straight M8-6H thread
Parallel key **A10x8x45** DIN6885
Max. torque 565 Nm

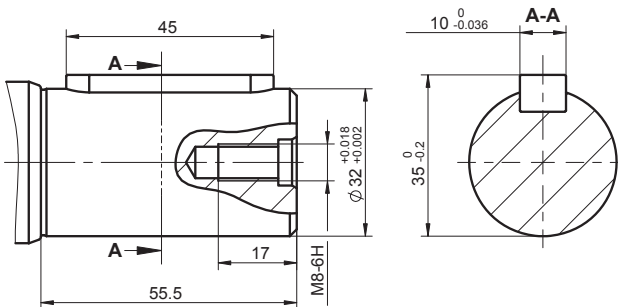

DU

∅ 38.1 straight 3/8-16 UNC-2B thread
Parallel key **3/4"x3/4"x1.1/2"** BS46
Max. torque 1000 Nm

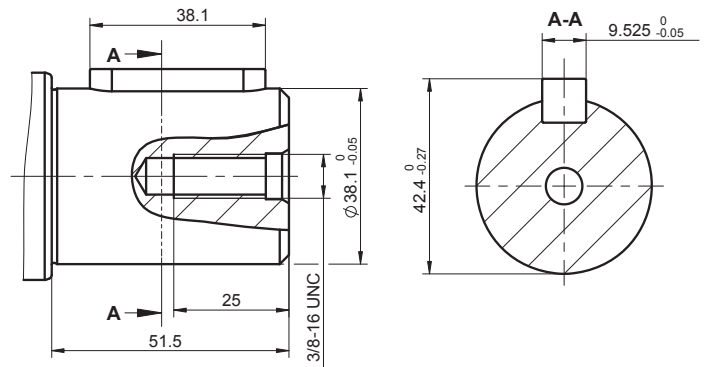

CV

∅ 40 straight M12-6H thread
Parallel key **A12x8x63** DIN6885
Max. torque 1100 Nm

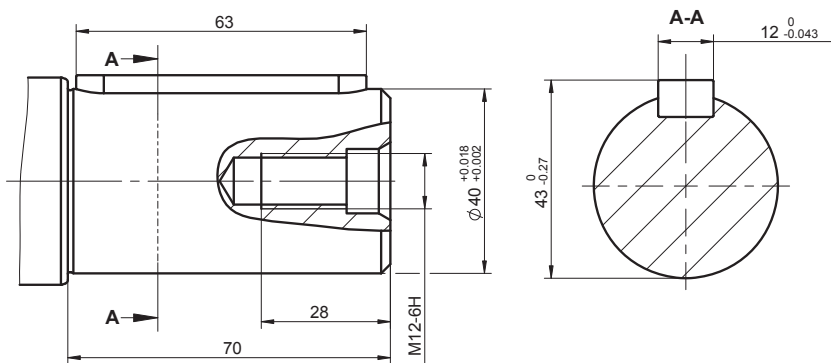

The required max. torque must not be exceeded

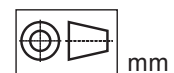

Speed Sensors

MOUNTING DIMENSIONS

TMF 28

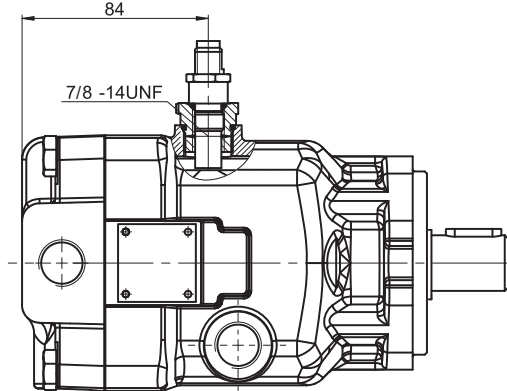
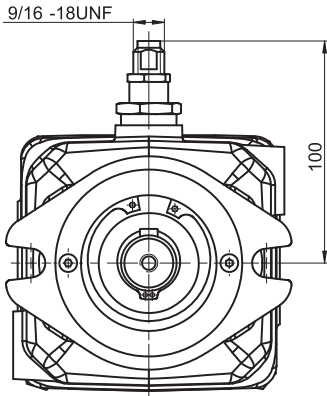

TMF 50

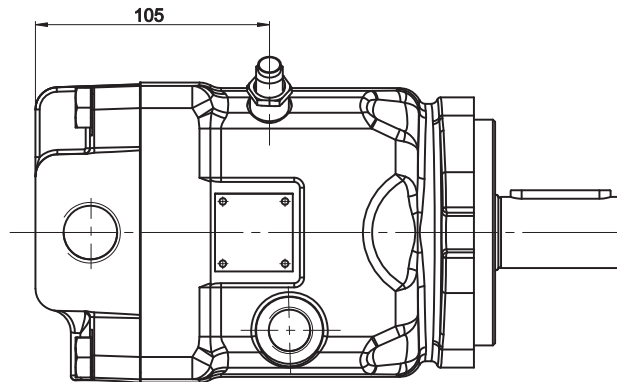
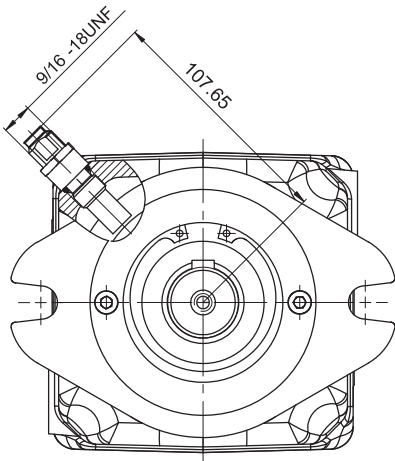

TMF 100

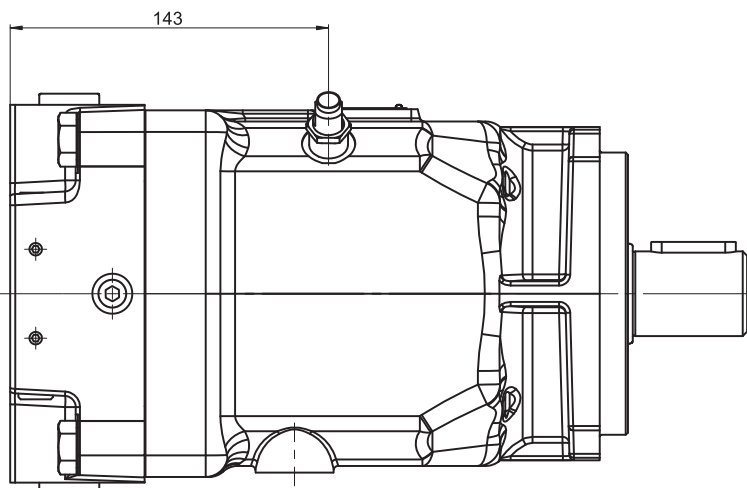
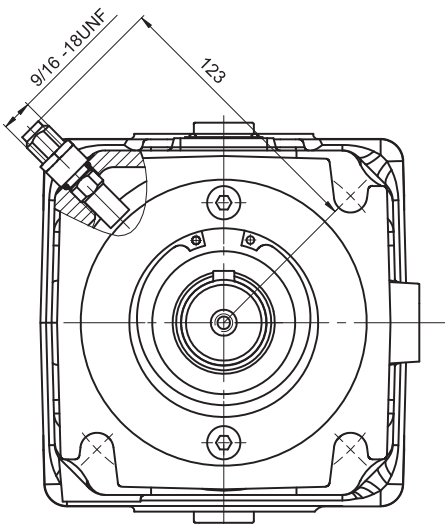

INSTALLATION

1. Turn in (CW) by hand until bottom end gently touches the speed ring.
2. Back out (CCW) 1/4 turn. Continue backing out until the flats are 22° either side of pump or motor shaft center line (20° to 30° is acceptable). Do not back out the sensor more than 3/4 of a turn from touching.
3. Using the 1/2 inch wrench to hold the sensor, torque the lock nut to 13 Nm with an 11/16 inch hew wrench.

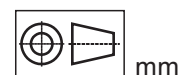

Speed Sensors

TECHNICAL DATA OF THE SPEED SENSOR

TECHNICAL DATA

Power supply	4.5 ... 30 VDC
Power consumption	< 15 mA without load
Pin connector	universal /PUSH-PULL/ 4P Delphi Connector DJ3042&-2.5-21
Output measurements	Speed, Direction
Output maximum current	100 mA
Resident output voltage	1.5 V with 100 mA of the output 0.5 V without load of the output
Frequency range	0 ... 15 000 Hz
Degree of protection	IP 67
Temperature	-40 ... + 100 °C
Humidity	0 ... 95% RH

OUTPUT PULSES

per revolution

Motor Type	TMF 28	TMF 50	TMF 100
Output Pulses	42	50	65

OUTPUT DIAGRAMS

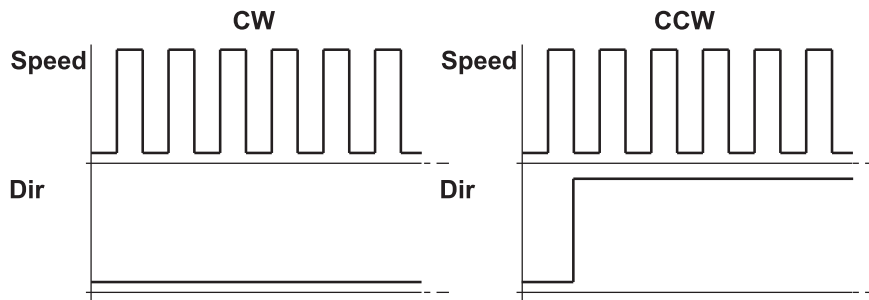

PIN CONNECTOR

4 pin Delphi Connector

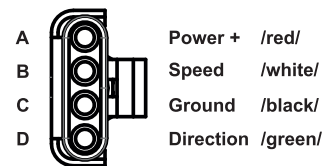

WIRING DIAGRAMS

Sensor could be in use for both type of connections - PNP or NPN

PNP

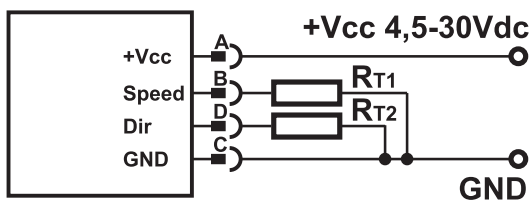

NPN

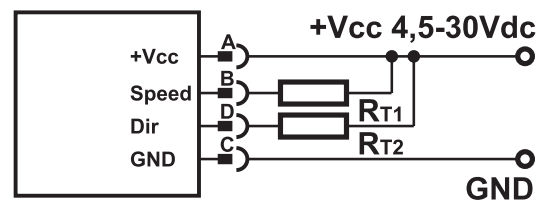

SENSOR OVERALL DIMENSIONS

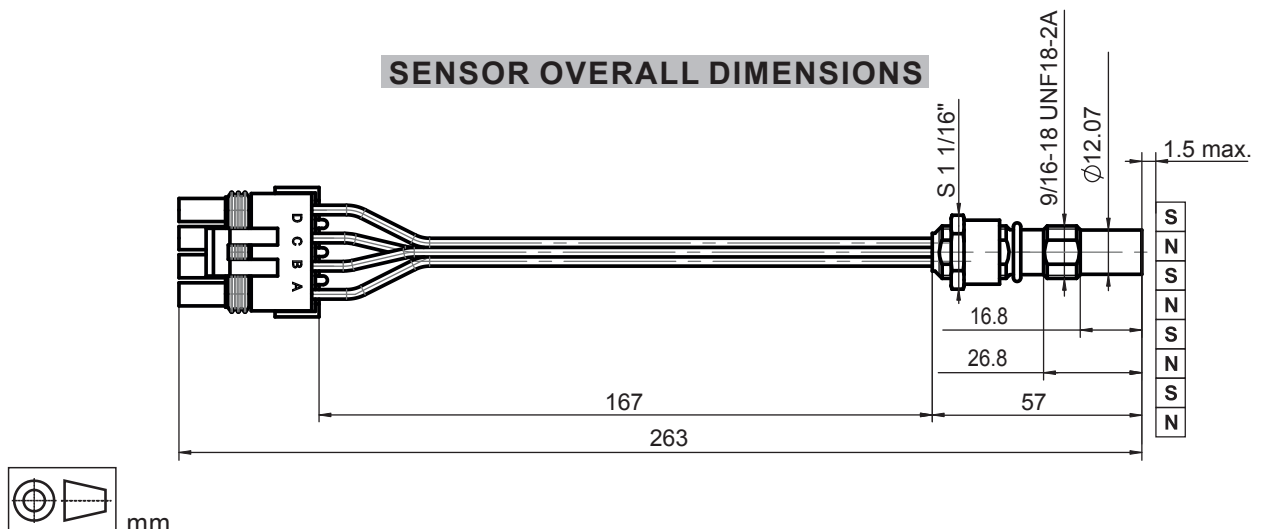

INSTALLATION

DIRECTION OF ROTATION

Standard Rotation

Viewed from shaft end
Port A Pressurized - CW
Port B Pressurized - CCW

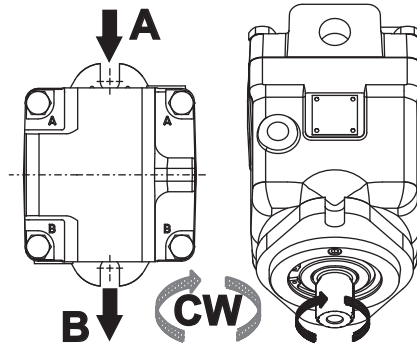

BEST POSITION FOR APPLYING RADIAL LOAD

Optimal position for applying radial load depending on the direction of rotation

Standard Rotation

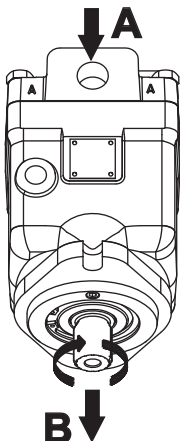
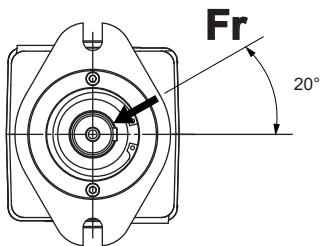

Reverse Rotation

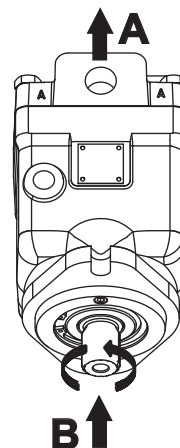
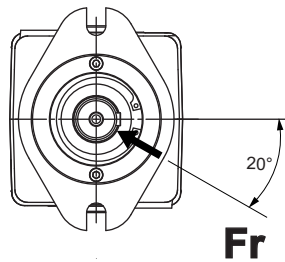

INSTALLATION

Recommended max. tightening torque X for metal plugs and orifice

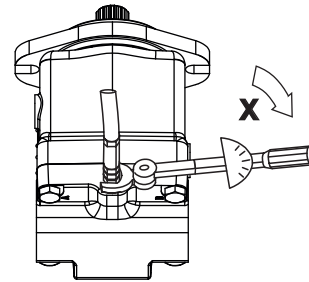
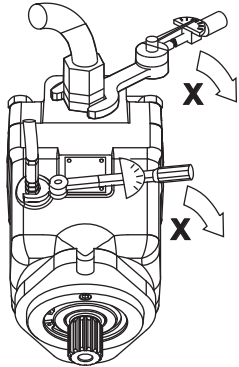

Screwed connection	Max. Tightening Torque X, daNm			
	With copper washer	With aluminium washer	With cutting edge	With "O" ring
G 1/4	2	3	4	2
G 3/8	2	5	6	2
G 1/2	3	8	10	3
G 3/4	5	13	16	5
G 1	8	20	25	8

INSTALLATION

At start-up and during operation the motor (pump) housing has to be filled up with hydraulic fluid. Start-up has to be carried out at low or moderate speed and without load (for example 1000 rpm and pressure 50 bar till the motor (pump) and the hydraulic scheme are filled up with oil. Generally the start-up needs 10-15 minutes to finish. The leakage oil in the housing has to be discharged to the tank through the highest positioned drain port D. The max. pressure in the drain line is 5 bar.

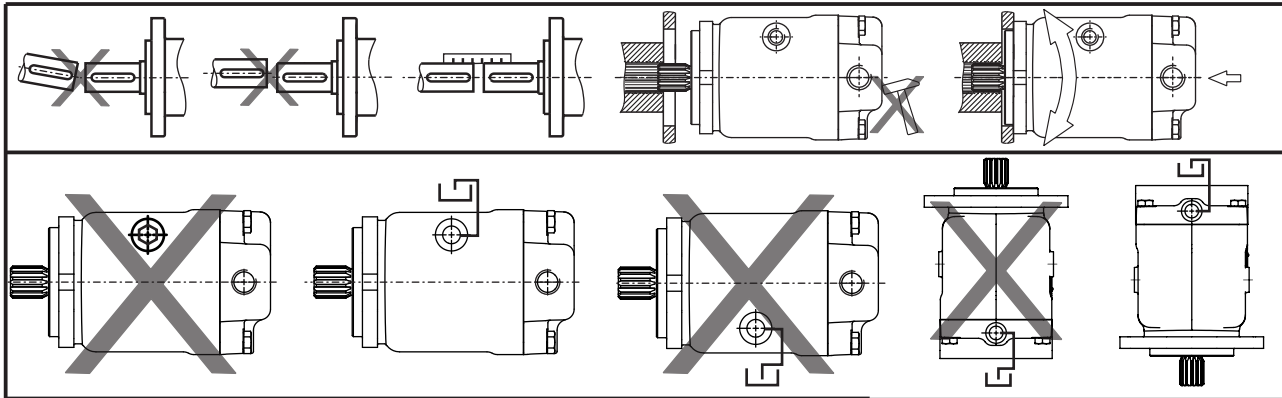

Installation below the tank level (recommended)

- Fill up the axial piston motor (pump) before the start-up through the highest positioned drain port D;
- Operate the motor (pump) at low speed till the motor system is completely filled up;
- The minimum immersion depth of the drain line in the tank is 200 mm relative to the minimum oil level in the tank.

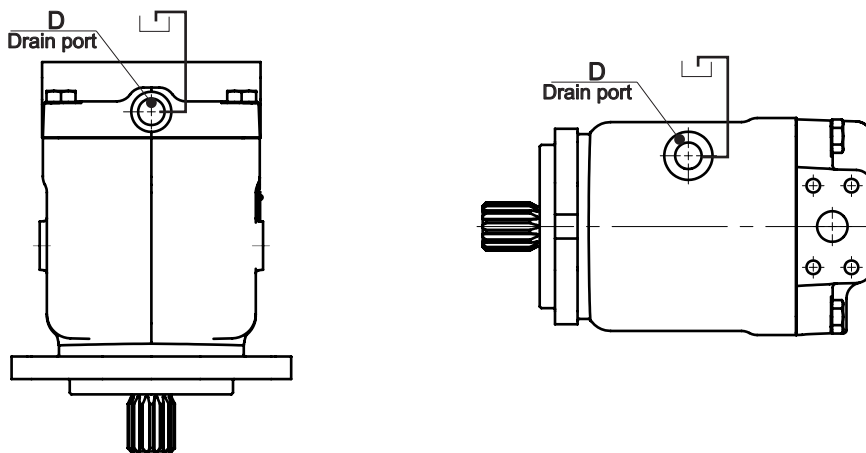

Installation on top of the tank level

- Fill up the axial piston motor (pump) before the start-up through the highest positioned drain port D;
- Operate the motor (pump) at low speed till the motor system is completely filled up;
- The minimum immersion depth of the drain line in the tank is 200 mm relative to the minimum oil level in the tank.

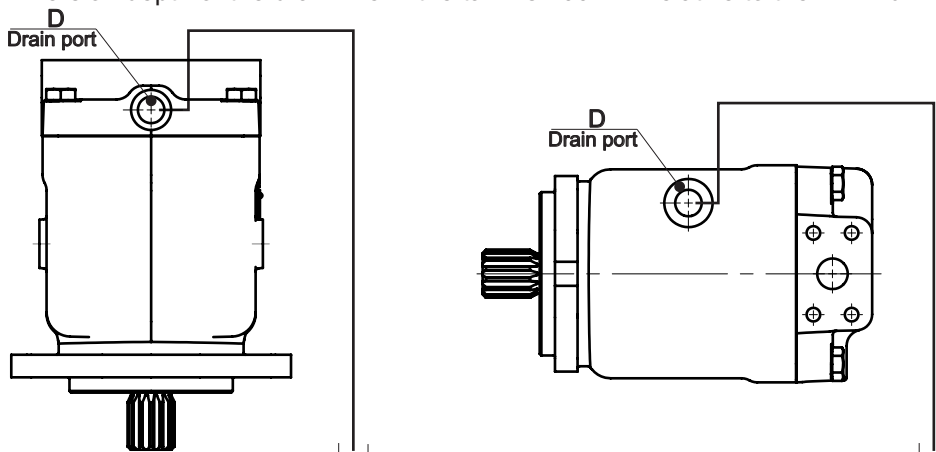

Fluid Viscosity Limits

In order to obtain optimum efficiency and service life, we recommend to select the operating viscosity (at operating temperature) within the range shown on diagram below.

Kinematic viscosity

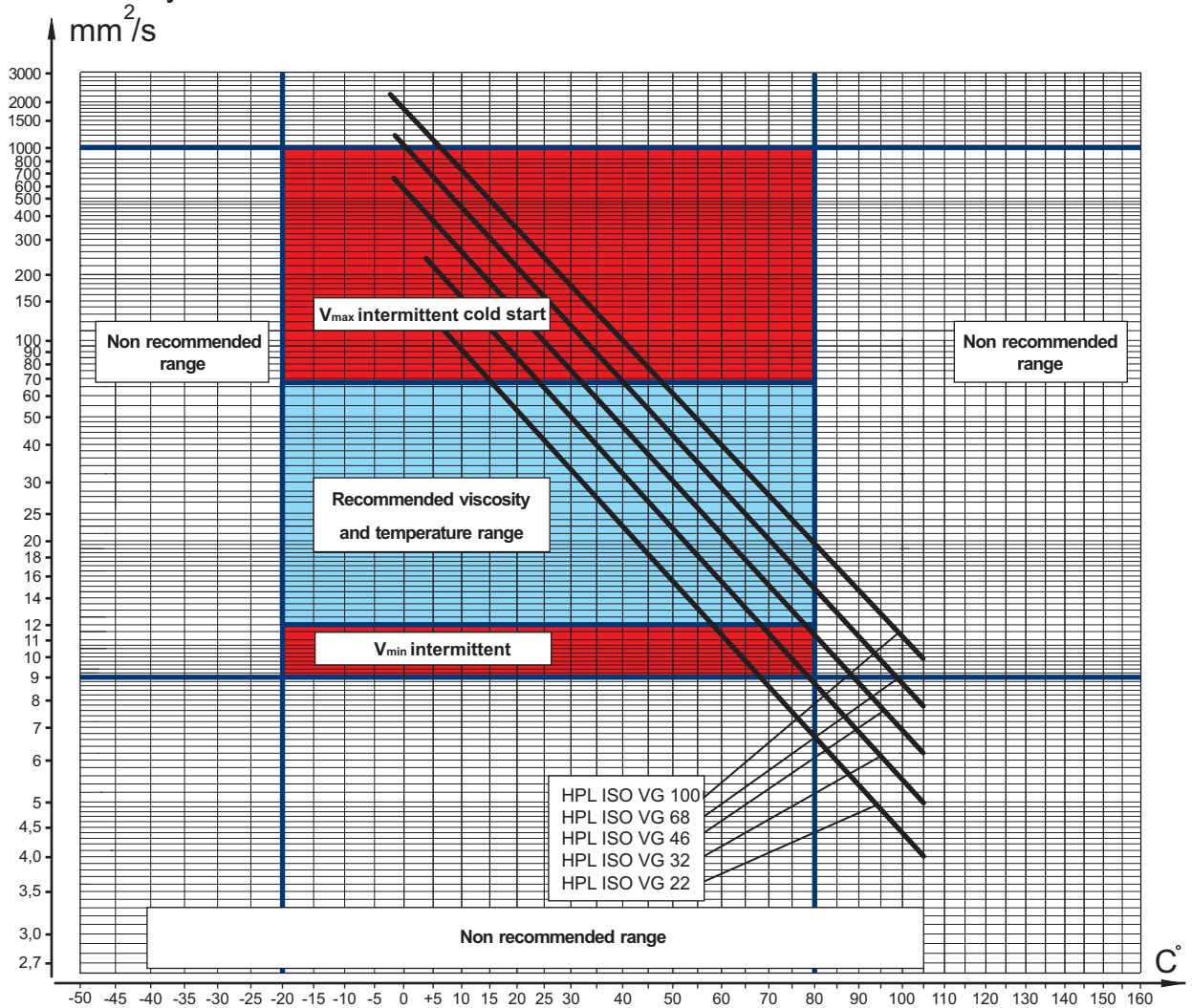

Temperature

The above - shown viscosity characteristics are for reference only. Please, check the actual viscosity with the manufacturer of the fluid.

Basic Formulas

The motor(pump) size, pressure and flow required for a specific application can be calculated using the formulas below.

Metric System

Efficiency	$\eta_t = \eta_{mh} \cdot \eta_v$ $\eta_{mh} = \frac{\eta_t}{\eta_v}$ $\eta_v = \frac{\eta_t}{\eta_{mh}}$	
Input flow (for Motor)	$Q = \frac{Vg \cdot n}{1000 \cdot \eta_v}$	[l/min]
Output torque (for Motor)	$M = \frac{Vg \cdot \Delta p \cdot \eta_{mh}}{62,8}$	[Nm]
Output power (for Motor)	$P = \frac{M \cdot n}{9550} = \frac{Q \cdot \Delta p \cdot \eta_t}{60}$	[kW]
Speed (for Motor)	$n = \frac{Q \cdot 1000 \cdot \eta_v}{Vg}$	[min ⁻¹]
Output flow (for pump)	$Q = \frac{Vg \cdot n \cdot \eta_v}{1000}$	[l/min]
Driving torque (for pump)	$M = \frac{Vg \cdot \Delta p}{62,8 \cdot \eta_{mh}}$	[Nm]
Input power (for pump)	$P = \frac{M \cdot n}{9550} = \frac{Q \cdot \Delta p}{60 \cdot \eta_t}$	[kW]
	$Vg =$ Displacement per rev.	[cm ³]
	$\Delta p =$ $p_{HP} - p_{LP}$	[bar]
	$p_{HP} =$ High pressure	[bar]
	$p_{LP} =$ Low pressure	[bar]
	$\eta_v =$ Volumetric efficiency	
	$\eta_{mh} =$ Mechanical-hydraulic efficiency	
	$\eta_t =$ Overall efficiency	

Application Formulas

Motor speed: n

$$n = \frac{2,65 \cdot v_{km} \cdot i}{R_m}$$

v_{km} - vehicle speed [km/h]

R_m - wheel rolling radius [m]

i - gear ratio between motor and wheels.

If no gearbox, use $i=1$.

Total tractive effort: TE, N

Total tractive effort **TE** is the total effort necessary for vehicle motion i.e. the sum of the calculated forces increased by 10 % because of air resistance.

$$TE = 1,1 \cdot (RR + GR + FA + DP)$$

RR - force required to overcome the rolling resistance

GR - force required to slope upwards

FA - force required to accelerate (acceleration force)

DP - additional tractive effort (trailer)

Motor Torque moment: M, Nm

Necessary torque for the hydraulic motor:

$$M = \frac{TE \cdot R_m}{N \cdot I \cdot \eta_M}$$

I – motor numbers

η_M - mechanical gearbox efficiency (if it is available)

Radial motor loading: P_{rad} , N

When the motor is used for motion with a ring or gear mounted directly on the motor shaft, the total radial load of the motor shaft P_{rad} is the sum of the motion force and the weight force acting on ring.

G_w - Weight held by the shaft

P_{rad} - Total radial load of the motor shaft

M/R - Motion force

$$P_{rad} = \sqrt{G_w^2 + \left(\frac{M}{R}\right)^2}$$

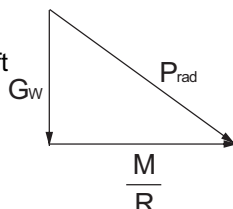

Depending on the results of the load calculations, the most appropriate type of motor from the catalogue is selected.

MOTORS



Axial Piston Motors (Two Speed) - 25-64 cc

Model	Displacement cm ³ /n.	Rated Pressure MPa	Peak Pressure MPa	Maximum speed n/min.	Weight kg
TMV 650 (plug-in)	25, 30, 35, 38, 45	30	35	3.500	15,6
TMV 550	46, 50, 64	30	40	4.000	20

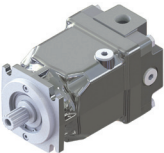

Axial Piston Motors (Fixed Displacement) - 22-110 cc

Model	Displacement cm ³ /n.	Rated Pressure MPa	Peak Pressure MPa	Maximum speed n/min.	Weight kg
TMF 600 (medium duty)	22, 28	35	42	4.200	11,3
	35, 40, 46			4.000	17,8
	50		41	3.600	32,5
	63, 71, 75, 92		42	3.500	
	100		41	3.240	
TMF 900 (heavy duty)	72	40	45	4.100	28
	90			4.000	34
	110			3.800	



Bent Axis Motors - 12-130 cc

Model	Displacement cm ³ /n.	Rated Pressure MPa	Peak Pressure MPa	Maximum speed n/min.	Weight kg
TMB 700	9.6, 12.6, 17.0	35	40	8.000	9
	25.4, 34.2			6.300	
	41.2, 47.1, 56.7, 63.5			5.700	15
	83.6, 90.7			4.700	18
	108.0, 130.0				35

The table values can change in function of the configuration.

As HANSA-TMP has a very extensive range of products and some products have a variety of applications, the information supplied may often only apply to specific situations.

If the catalogue does not supply all the information required, please contact HANSA-TMP.

In order to provide a comprehensive reply to queries we may require specific data regarding the proposed application.

Whilst every reasonable endeavour has been made to ensure accuracy, this publication cannot be considered to represent part of any contract, whether expressed or implied.

The data in this catalogue refer to the standard product. The policy of HANSA-TMP consists of a continuous improvement of its products. It reserves the right to change the specifications of the different products whenever necessary and without giving prior information.



HANSA-TMP S.r.l.

Via M. L. King, 6 – 41122 Modena (ITALY)
Tel.: +39 059 415 711
Fax: +39 059 415 730
E-mail: hansatmp@hansatmp.it
Website: www.hansatmp.it

Certified Company
ISO 9001:2015 – ISO 14001:2015



Share Capital: € 300.000,00
VAT Number: IT01167360369
REA Number: MO-225785