



HANSA-TMP

MANUFACTURING YOUR SUCCESS

HT 12 / A / 404 / 0621 / E

Mechanical Clutches

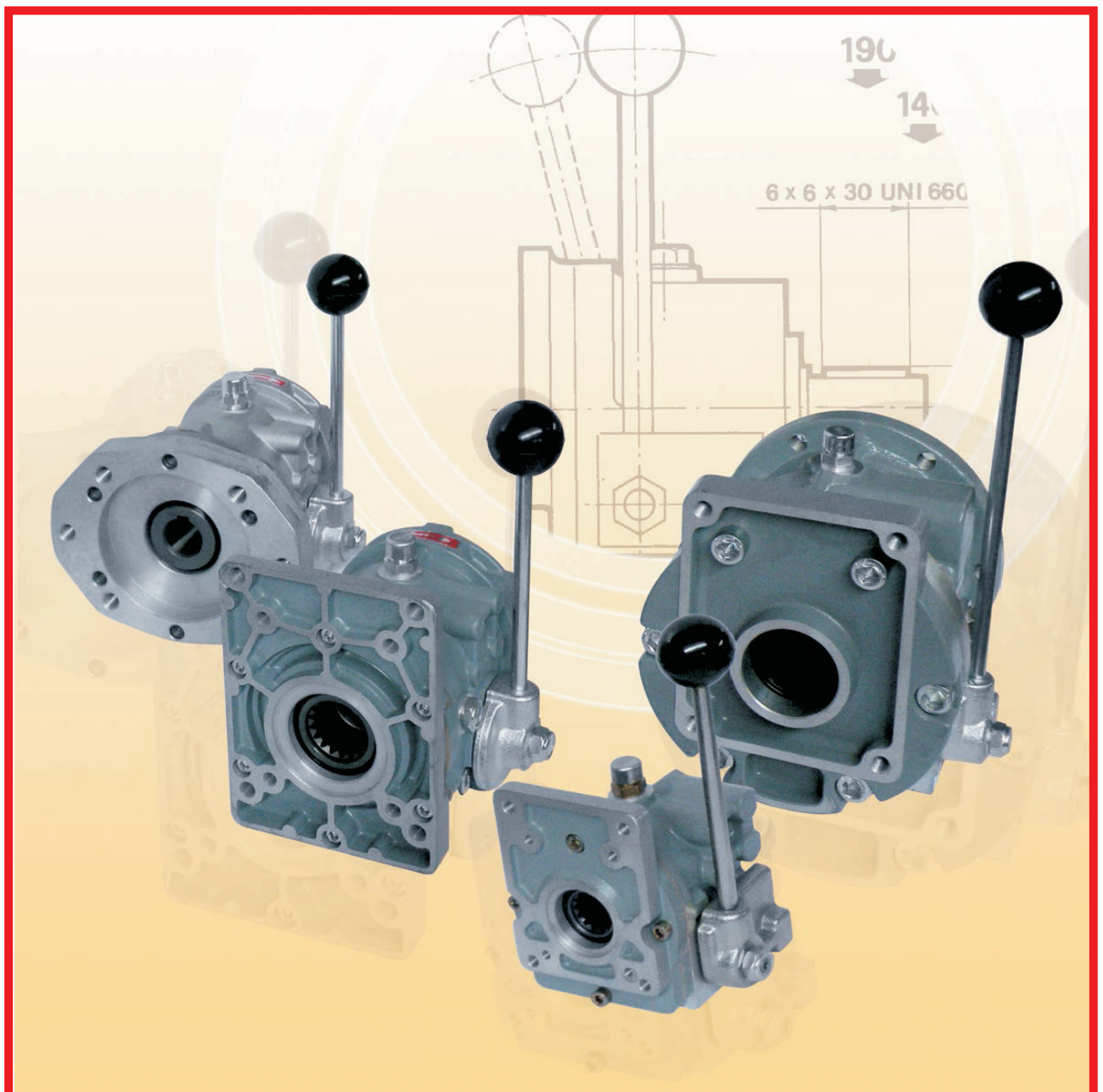

Contents

General Information.....	4 - 5
Mechanical Clutches Series 30100.....	6 - 7
Mechanical Clutches Series 30300.....	8 - 11
Mechanical Clutches Series 30500.....	12 - 15

General Information

Front Teeth Mechanical Clutches Series 30100 - 30300 - 30500

They are unidirectional and bidirectional.

When coupled with hydraulic pumps we recommend to engage and disengage the pump when the directional valve is in neutral position and at a speed not higher than 1800 n/min.

For reversible models the max.engagement and disengagement speed is max. 1000 n/min.

Lubrication

- Oil type SAE 90
- Change oil every 12 months
- Max. working temperature +80°C
- Min. working temperature -10°C

General Information

Front Teeth Mechanical Clutches

Product Overview

Front teeth mechanical clutches series	Torque daNm	Pump Group	Pump Flanges	Housing
30100	9	Gr. 1 - 2	Gr. 1 - 2 Gr. 2 Bosch	Aluminium
30300	18,5	Gr. 2 - 3	Gr. 2 - 3 Gr. 2 - 3 Bosch SAE A - B	Aluminium
30500	58	Gr. 3,5 - 4	Gr.1 - 2 - 3 - 3,5 - 4 Gr. 3 Bosch SAE A - B - C Linde 20-35-50-75	Aluminium

Front Teeth Mechanical Clutches Series 30100 Torque 9 daNm - Pump Group 1 - 2

INSTALLATION DRAWING

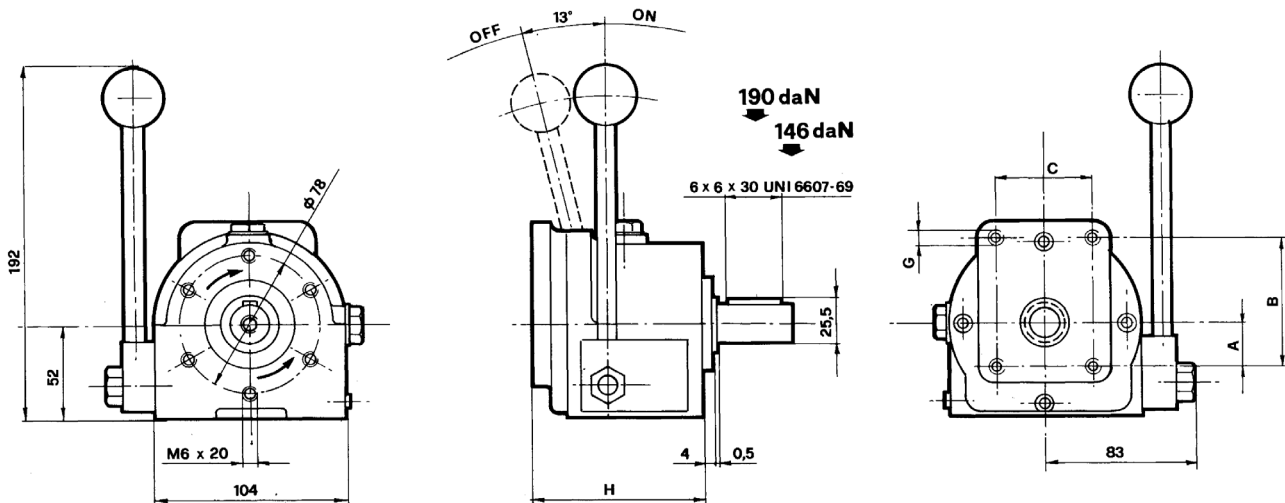
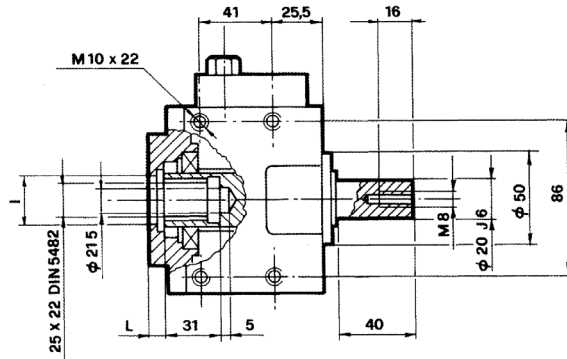

The mechanical clutches with two direction arrow are REVERSIBLE

Nominal torque daNm	Max. speed n/min.	Max. power output kW	Axial load daN
9	2000	30	120

CODE No.	DIRECTION OF ROTATION	PUMP GROUP	A	B	C	G	H	I	L
30100	REVERSIBLE	1	26.3	72	52.4	M6x12	92.5	25.4 H7	7
30103	CLOCKWISE								
30104	COUNTERCLOCKWISE	2	32.5	96	71.4	M8x15	95.5	36,5 H7	10
30100/B	REVERSIBLE	2 BOSCH	34.5	100	72	M8x15	95.5	80 H7	10
30105	CLOCKWISE								
30106	COUNTERCLOCKWISE								

Front Teeth Mechanical Clutches Series 30100

Torque 9 daNm - Pump Group 1 - 2

ORDER CODE

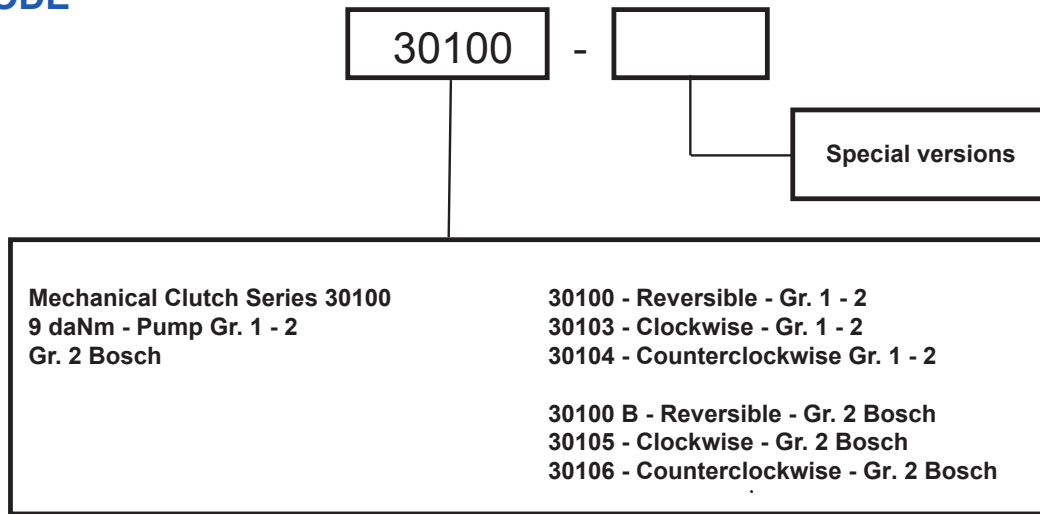

SPARE PARTS LIST

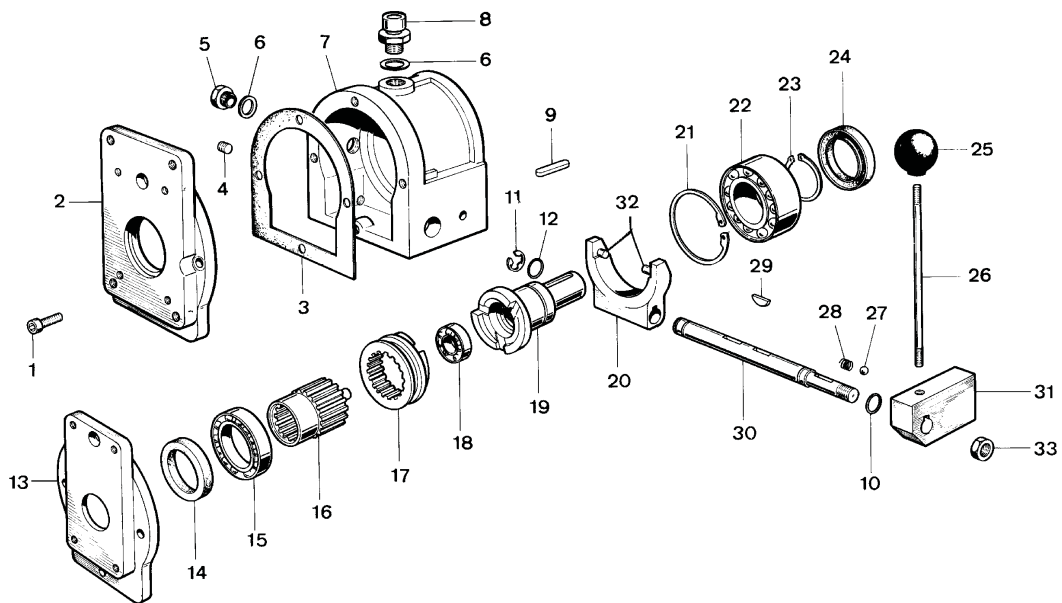

Ref.	CODE	DESCRIPTION	Q.ty
1	610625	Socket Capscrew M6x20	4
2	30100.1	Flange for pump Group 1 and 2	1
3	30100.1.2	Gasket	1
4	940182	Oil drain dowel 1/8" G	1
5	940141	Oil level plug 1/4" G	1
6	940144	Gasket	2
7	30001.1	Housing	1
8	940143	Oil breather plug	1
9	426630	Key 6x30	1
10	401090	Washer OR 109	1
11	311000	Snap ring d.10	1
12	402031	Washer OR 2031	1
13	on request	Flange for pump Group 1	1
14	303040	Sealing Ring	1
15	501600	Bearing 16006	1
16	AEP30001	Infeed splined shaft	1
17	MCRV30001	Splined sleeve reversible	1
	MCDX30001	Splined sleeve right	
	MCSX30001	Splined sleeve left	

Ref.	CODE	DESCRIPTION	Q.ty
18	506080	Bearing 608	1
19	AURPc30001	Outfeed shaft reversible	
	AUDPc30001	Outfeed shaft right	1
	AUSPc30001	Outfeed shaft left	
20	30013.1	Fork	1
21	916200	Snap Ring	1
22	503206	Bearing 3206	1
23	903000	Snap Ring	1
24	303040	Sealing Ring 30x40x7	1
25	721008	Knob	1
26	30013.1.2	Rod M10	1
27	920786	Ball d. 7.82	1
28	000150	Spring	1
29	700465	Woodruff key 4x6.5x16	3
30	APF30001	Fork shaft	1
31	44001	Plate	1
32	30013.1.1	Fork pin	2
33	601001	Nut M10	1

Front Teeth Mechanical Clutches Series 30300

Torque 18,5 daNm - Pump Group 2 - 3

INSTALLATION DRAWING

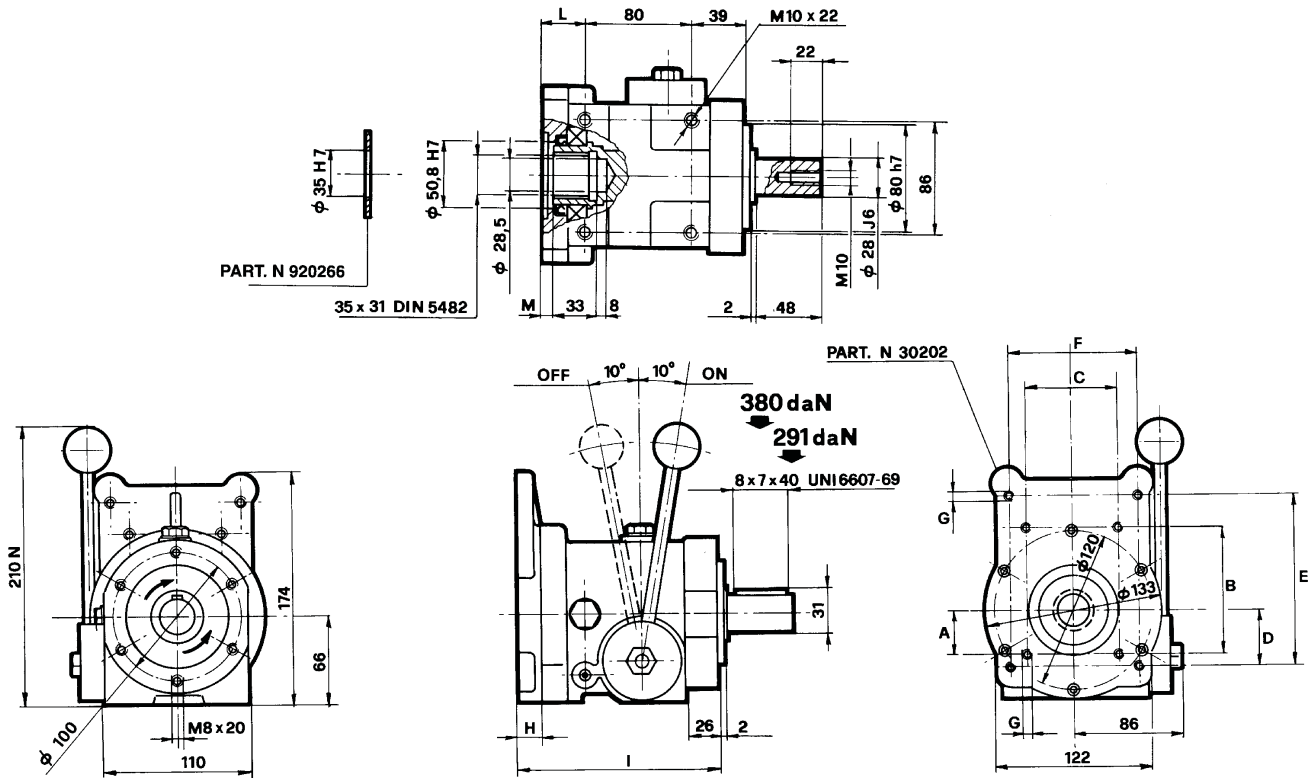

The mechanical clutches with two direction arrow are **REVERSIBLE**

Nominal torque daNm	Max. speed n/min.	Max. power output kW	Axial load daN
18,5	2700	40	160

CODE No.	DIRECTION OF ROTATION	PUMP GROUP FLANGE N°	A	B	C	D	E	F	G	H	I	L	M	N	O H7	P
30300 30301 30302	REVERSIBLE CLOCKWISE COUNTERCLOCKWISE	2-3 30202	32.5	96	71.4	42.5	128	98.4	M8x15	19	151	32	8.6			
30313 30307 30308	REVERSIBLE CLOCKWISE COUNTERCLOCKWISE	2 BOSCH 30217	34.5	100	72				M8x15	19	151	32	8.6	8.5	80	
30314 30309 30310	REVERSIBLE CLOCKWISE COUNTERCLOCKWISE	3 BOSCH 30228	48	145	102				M10x15	19.5	151.5	32.5	9.1	9	105	
30311 30303 30304	REVERSIBLE CLOCKWISE COUNTERCLOCKWISE	SAE A 30203					106.4		M10x22	34	166	47	23.6	15	82.55	
30312 30305 30306	REVERSIBLE CLOCKWISE COUNTERCLOCKWISE	SAE B 30221					146		M12x22	39	171	52	28.6	20	101.6	M12x22

Flanges for Front Teeth Mechanical Clutches Series 30300

SAE Flange

**SAE A 30203
SAE B 30221**

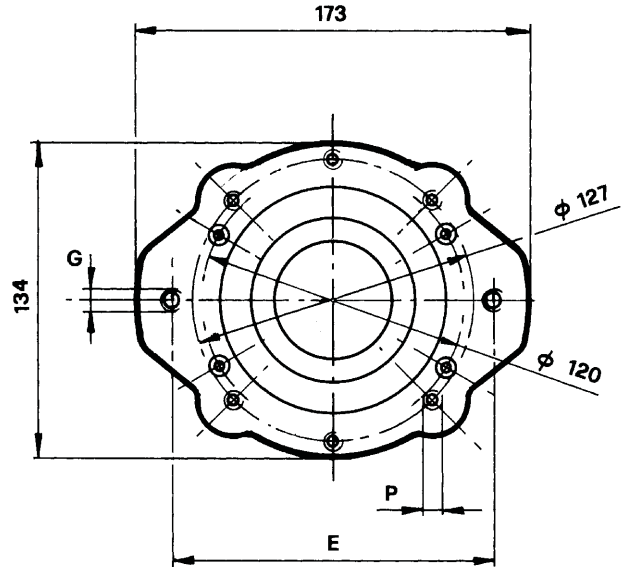
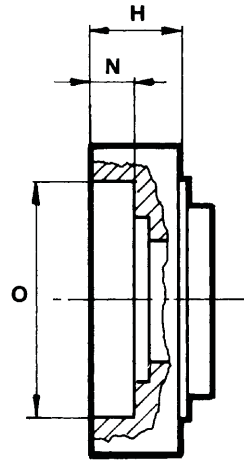

BOSCH Flange
**B2 30217
B3 30228**

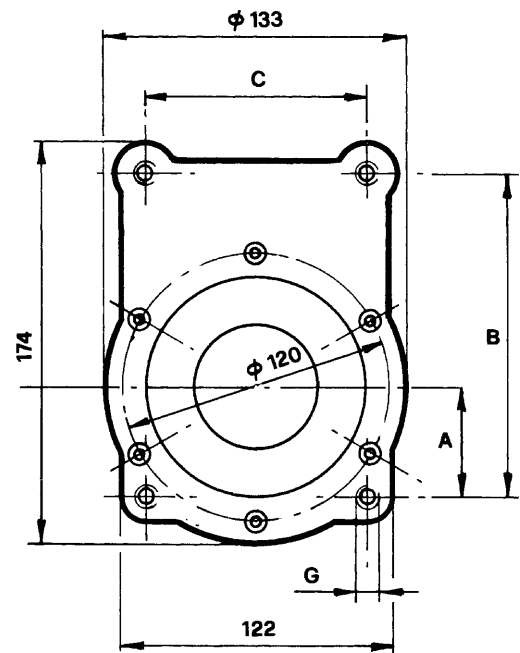
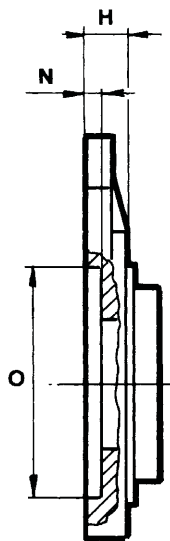

Front Teeth Mechanical Clutches Series 30300

Torque 18,5 daNm - Pump Group 2 - 3

ORDER CODE

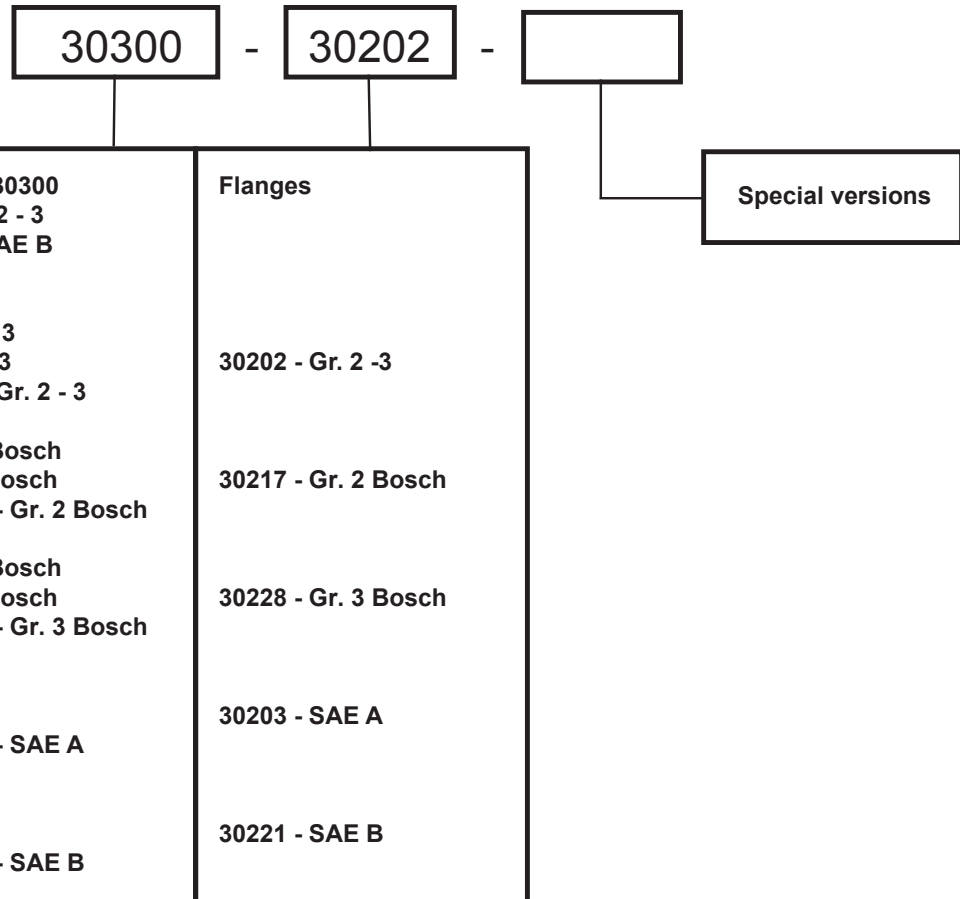

Front Teeth Mechanical Clutches Series 30300

Torque 18,5 daNm - Pump Group 2 - 3

SPARE PARTS LIST

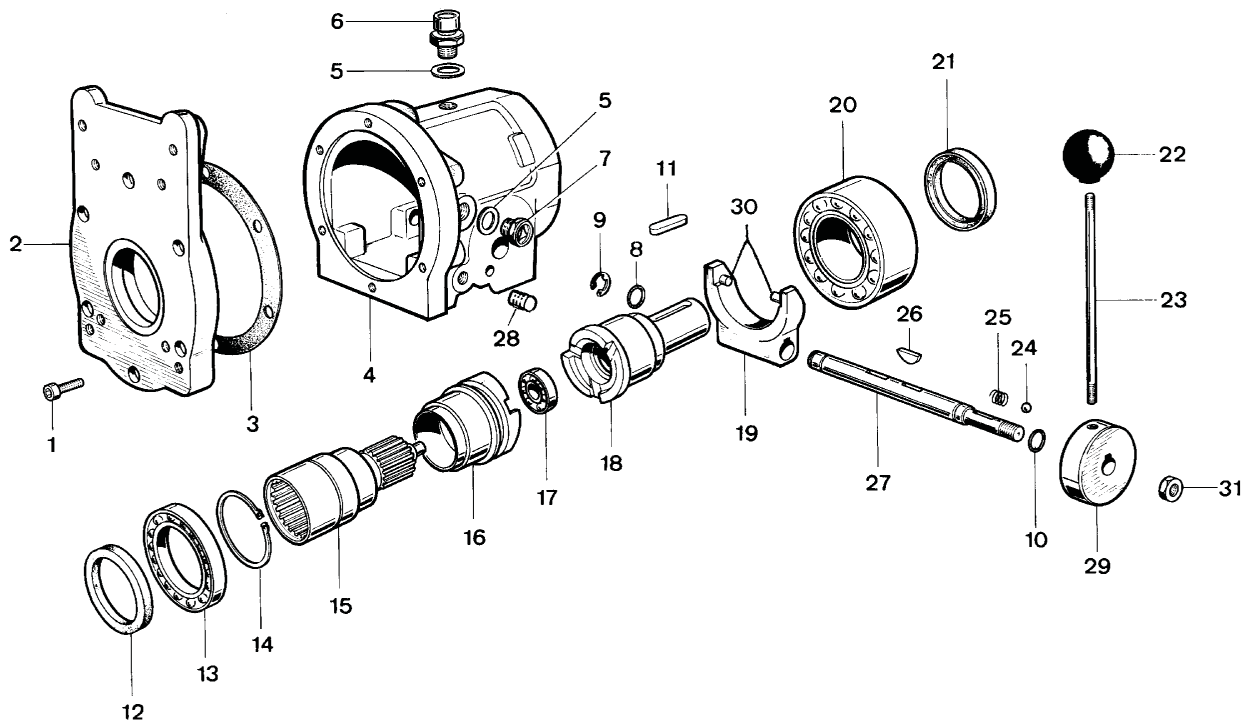

REF.	CODE	DESCRIPTION	Q.ty
1	610625	Socket Capscrew M6x25	6
2	30300.1	Flange for pump Group 2 and 3	1
3	30300.1.2	Gasket	1
4	30003.1	Housing	1
5	940144	Gasket	2
6	940143	Oil breather plug	1
7	940141	Oil level plug	1
8	402031	Washer OR 2031	1
9	311000	Snap ring d.10	1
10	411090	O-Ring OR 109	1
11	428740	Key 8x40	1
12	304560	Sealing Ring 45x60x7	1
13	506009	Bearing 6009	1
14	904500	Snap Ring	1
15	AEP30003	Infeed splined shaft	1
16	MCRV30003	Splined sleeve reversible	1
	MCDX30003	Splined sleeve right	
	MCSX30003	Splined sleeve left	

REF.	CODE	DESCRIPTION	Q.ty
17	506200	Bearing 6200	1
18	AURPc30003	Outfeed shaft reversible	1
	AUDPc30003	Outfeed shaft right	
	AUSPc30003	Outfeed shaft left	
19	30013.1	Fork	1
20	503209	Bearing 3209	1
21	304052	Sealing Ring 40x52x7	1
22	721008	Knob	1
23	30013.1.2	Rod M10	1
24	920786	Ball d. 7.82	1
25	000150	Spring	1
26	700465	Woodruff key 4x6.5x16	3
27	APF30003	Fork shaft	1
28	940182	Oil drain dowel 1/8" G	1
29	44002	Plate	1
30	30013.1.1	Fork pin	2
31	601001	Nut M10	1

Front Teeth Mechanical Clutches Series 30500

Torque 58 daNm - Pump Group 3,5 - 4

INSTALLATION DRAWING

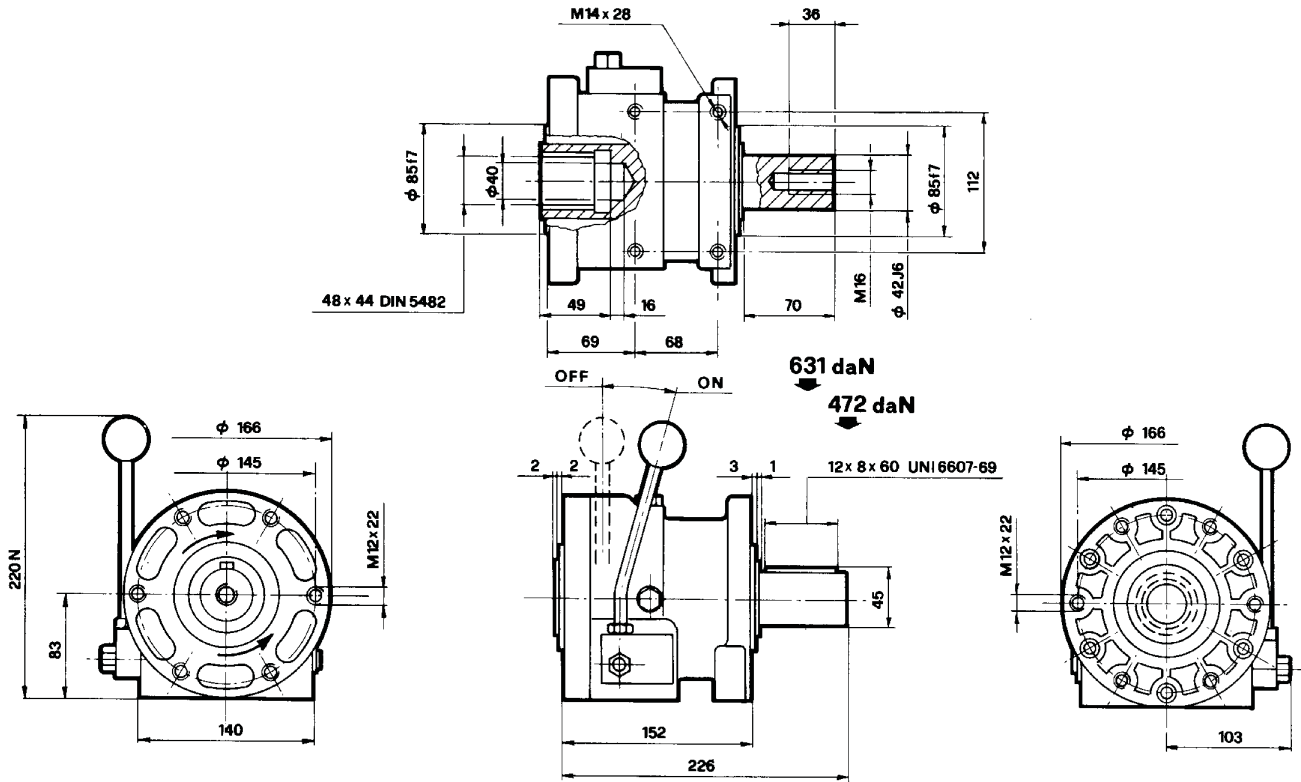

The mechanical clutches with two direction arrow are REVERSIBLE

CODE	No.	DIRECTION OF ROTATION
30500		REVERSIBLE
30501		CLOCKWISE
30502		COUNTERCLOCKWISE

PUMP FLANGES													
FLANGE CODE No.	PUMP GROUP	A	B	C	D	E H7	F	G	H	I	L	M	N
30400	Gr.2							17	21				
30401	Gr.3							21	23				
30402	Gr. 3.5	49.3	149.5	114.3	M10x20	60.3		11.5	24				
30403	Gr. 4	64.5	188	143	M12x22	63.5		16	23				
30417	Gr. 3 BOSCH	48	145	102	M10x15	105		12	19				
30420	SAE A					82.55	M12x20	21	25	106		M12x25	
30422	SAE B					101.6	M12x20	12	25	146		M12x25	127
30432	SAE C					127	M14x25	16	28	181		M16x25	162
30462	L.G. 50				M10x25	100		32.5	41		160		
30463	L.G. 75				M12x25	105		33	41		180		

Flanges for Front Teeth Mechanical Clutches Series 30500

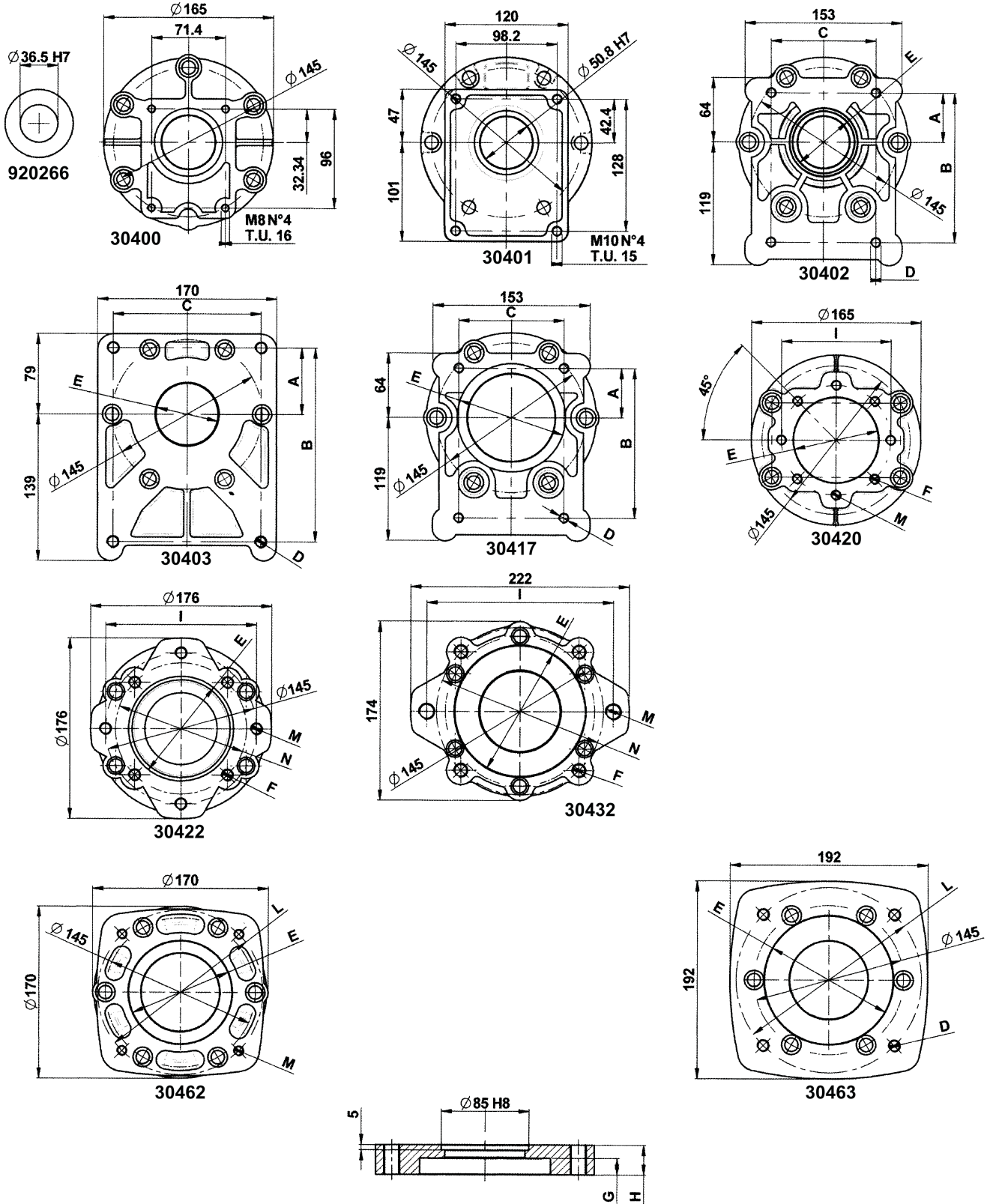

Front Teeth Mechanical Clutches Series 30500

Torque 58 daNm - Pump Group 3,5 - 4

ORDER CODE

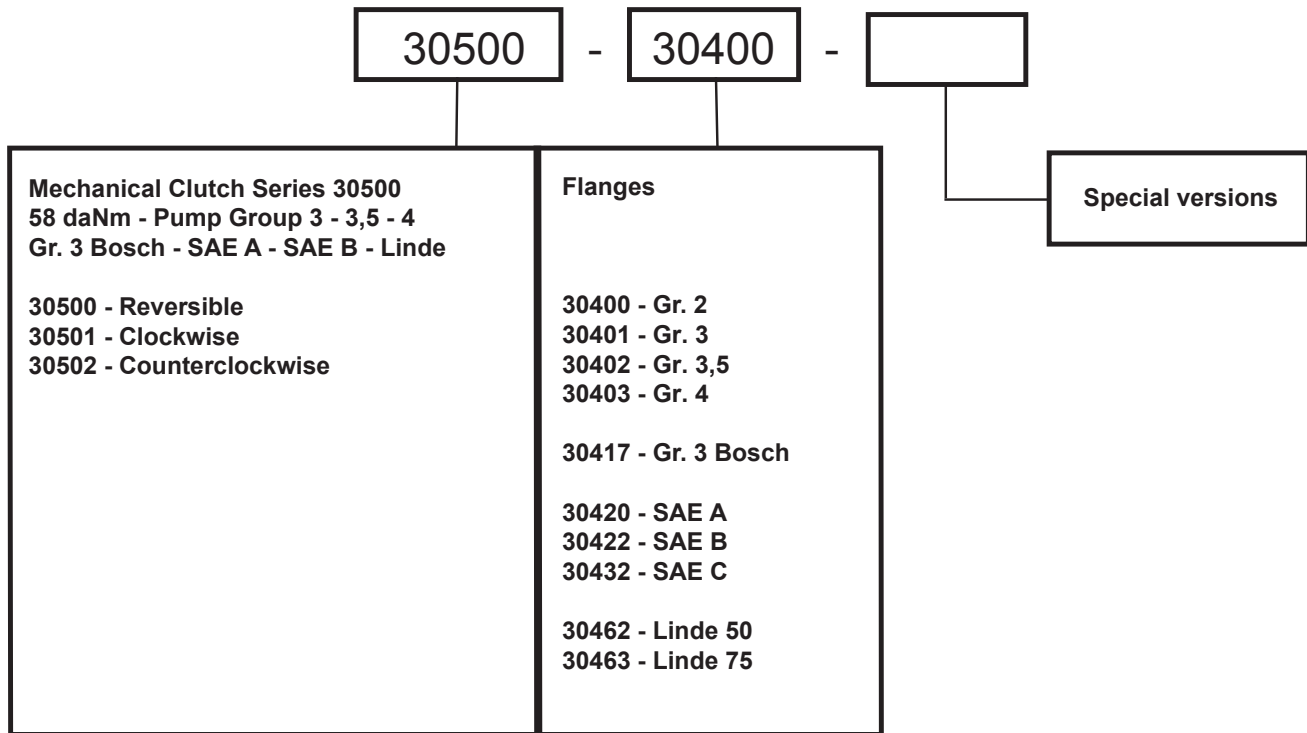

Front Teeth Mechanical Clutches Series 30500 Torque 58 daNm - Pump Group 3,5 - 4

SPARE PARTS LIST

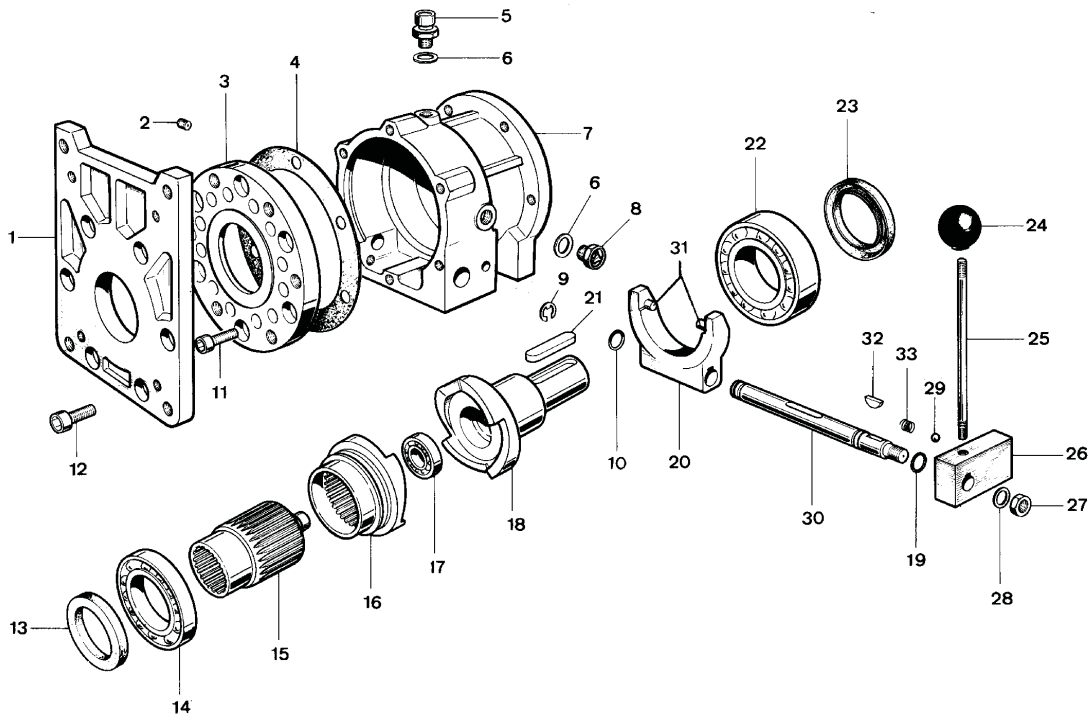

REF.	CODE	DESCRIPTION	Q.ty
1	30403	Flange for pump Group 4	1
2	940182	Oil drain dowel 1/8" G	1
3	30470	Circular Flange	1
4	30470.2	Gasket	1
5	940143	Oil breather plug 3/8"G	1
6	940144	Gasket	2
7	30005.1	Housing	1
8	940141	Oil level plug 3/8" G	1
9	312000	Snap ring d.12	1
10	401090	Washer OR 109	1
11	611025	Socket Capscrew M10x25	6
12	612020	Socket Capscrew M12x20	6
13	306075	Sealing Ring 60x75x8	1
14	501601	Bearing 16012	1
15	AEP30005	Infeed splined shaft	1
16	MCRV30005	Splined sleeve reversible	1
	MCDX30005	Splined sleeve right	
	MCSX30005	Splined sleeve left	

REF.	CODE	DESCRIPTION	Q.ty
17	506203	Bearing 6203	1
18	AURP 30005	Outfeed shaft reversible	1
	AUDP 30005	Outfeed shaft right	
	AUSP 30005	Outfeed shaft left	
19	401130	Washer OR 113	1
20	30050.1	Fork	1
21	421286	Key 12x8x60	1
22	503212	Bearing 3212	1
23	306075	Sealing Ring 60x75x8	1
24	721008	Knob	1
25	30013.1.3	Rod M10	1
26	44001.1	Plate	1
27	601001	Nut M10	1
28	801000	Washer d.10	1
29	920786	Ball d. 7.82	1
30	APF30005	Shaft d.15	1
31	30013.1.1	Fork pin	2
32	700565	Woodruff key 5x6.5x16	3
33	000280	Spring	1

As HANSA-TMP has a very extensive range of products and some products have a variety of applications, the information supplied may often only apply to specific situations.

If the catalogue does not supply all the information required, please contact HANSA-TMP.

In order to provide a comprehensive reply to queries we may require specific data regarding the proposed application.

Whilst every reasonable endeavour has been made to ensure accuracy, this publication cannot be considered to represent part of any contract, whether expressed or implied.

HANSA-TMP reserves the right to amend specifications at their discretion.



HANSA-TMP S.r.l.

Via M. L. King, 6 – 41122 Modena (ITALY)

Tel.: +39 059 415 711

Fax: +39 059 415 730

E-mail: hansatmp@hansatmp.it

Website: www.hansatmp.it

Certified Company

ISO 9001:2015 – ISO 14001:2015



Share Capital: € 300.000,00

VAT Number: IT01167360369

REA Number: MO-225785