

CONTROL VALVES

for mounting on orbital motors



INDEX

GENERAL INFORMATION	2
PRESSURE RELIEF VALVES	3 – 51
ANTISHOCK VALVES	53 – 61
CHECK VALVES	63 – 69
OVERCENTER VALVES	71 – 101
MOTION CONTROL VALVES	103 – 117
FLOW CONTROL VALVES	119 – 138

CONTROL VALVES for MOUNTING on DANFOSS MOTORS

GENERAL INFORMATIONS

This valves are manufactured to be mounted directly on board of the Danfoss motors .
Valves production is achieved using sophisticated procedures : a project begin using CAD station, and valves are produced using automatic machines .

This valve series include all the necessary control functions that a hydraulic system require and are for flange mounting directly on board of the orbit motors.

They are divided into :

- **Pressure Relief Valves**
Control and protect plant or single application.
Available in direct and differential version.
- **Antishock Valves**
Allows pressure relief on motor delivery line .
When the actuator is braking , the included check valves allow for anticavitation.
- **Check Valves**
When the actuator is braking , the check valves allow for anticavitation.
- **Overcenter and Motion Control Valves**
Modulate and check movements of unstable loads, guarantee integrity and phisical safety of the operator, in accordance with required safety rules.
- **Flow Control Valves**
Available in 2 or 3 way pressure compensated version to provide a flow ajustement.
- **Special Valves**
Our technical staff have long experience in hydraulic and this means that projects for integrated valves and personalizations of standard product can be undertaken to comply with specific customer requirements.

FILTRATION

General Information: Very often the cause of failure in hydraulic system and components is found to be excessive fluid contamination..

The hard contaminant particles in the fluid wear the hydraulic components and prevent the poppets from re-seating with consequent internal leakage and system inefficiency.

For the correct operations with our valves it is necessary to ensure a fluid cleaning class as follow:

- | | |
|---------------------------------------------|------------------------|
| - High Pressure Systems (210 – 350 bar) | Class 16 / 13 ISO 4406 |
| - Medium Pressure Systems (up to 210 bar) | Class 18 / 14 ISO 4406 |
| - Low Pressure Systems | Class 19 / 15 ISO 4406 |

unless otherwise specified in the relevant components technical data sheet .

Contamination Class ISO 4406 it's expressed by two scale number representing the number of particles larger than 5 micron and larger than 15 micron contained in 1 ml of fluid.

PRESSURE RELIEF VALVES INDEX

Description	type	code	page
Single cross-line relief valve	VAIF / D5S / 03 38 / OMM	A.1110.100	4
Single cross-line relief valve with anti-cav.	VAIF / D5S / VA / 03 38 / OMM	A.1110.105	6
Dual cross- line relief valve	VAIF / D5D / 03 38 / OMM	A.1110.150	8
Single cross-line relief valve	VAIF / D1S / 12 / OMR	A.1110.200	10
Single cross-line relief valve	VAIF / 5 / D1S / 12 / OMR	A.1110.205	12
Single cross-line relief valve	VAIF / 5Y / D1S / 12 / OMR	A.1110.210	14
Dual cross- line relief valve	VAIF / D1D / 12 / OMR	A.1110.250	16
Dual cross- line relief valve	VAIF / 5 / D1D / 12 / OMR	A.1110.255	18
Dual cross- line relief valve	VAIF / 5 Y / D1D / 12 / OMR	A.1110.260	20
Dual cross- line relief valve	VAIF 10 / D1D / 12 / OMR	A.1110.265	22
Single cross-line relief valve	VAIF / 12 / S 12 / OMS	A.1110.300	24
Dual cross- line relief valve	VAIF 12 / D12 / OMS	A.1110.350	26
Dual cross- line relief valve	VAIF / 5 / D12 / OMS	A.1110.355	28
Single cross-line relief valve	VAIF / 5Y / D1S / SF 12 / OMR	A.1112.200	30
Dual cross- line relief valve	VAIF / 5Y / D1D / 12 / SF / OMR	A.1112.250	32
Single cross-line relief valve	VADDF / OMS / S / 12	A.1120.300	34
Dual cross-line relief valve	VADDF / OMS / D / 12	A.1120.320	36
Dual cross-line relief valve	VADDF / OMS / D / SF / 12	A.1120.350	38
Single cross-line relief valve	VADDF / OMT / S 34	A.1120.400	40
Dual cross-line relief valve	VADDF / OMT / D / 34	A.1120.420	42
Dual cross-line relief valve	VADDF / OMT / D / SF 34	A.1120.450	44
Single cross-line relief valve	VADDF / OMV / S 100	A.1120.500	46
Dual cross-line relief valve	VADDF / OMV / D 100	A.1120.550	48
Dual cross-line relief valve with anti-cav.	VAIF / VA 12 / OMS	A.1130.350	50

• DIMENSIONS (mm)

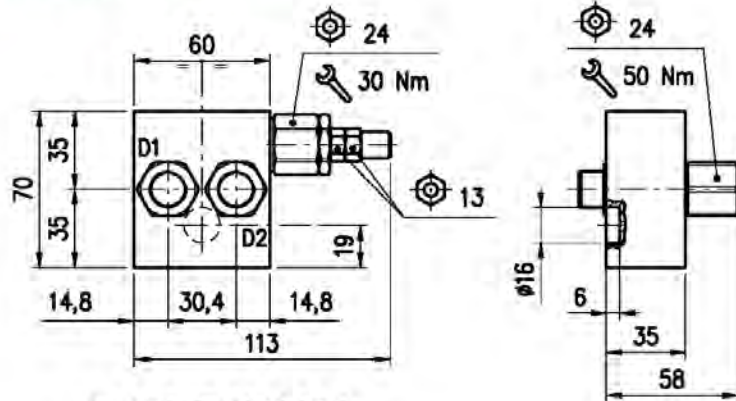

n° 4 WASHER 22x16,8x1,5
Cod. 4RD1161501

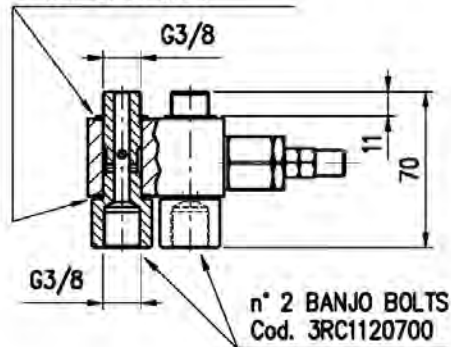

• HYDRAULIC DIAGRAM

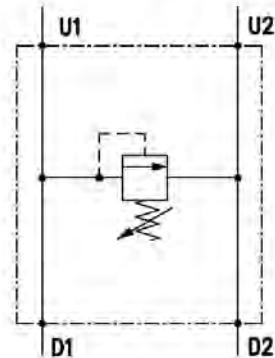

• ASSEMBLY DIAGRAM

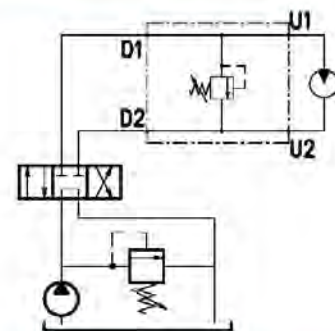

• DESCRIPTION

Single cross-line relief valve. Direct acting, poppet type, face mounting for Sauer-Danfoss motor OMM series, including banjo bolts and washers.

• OPERATION

Allows pressure relief on delivery pipes to engines and cylinders.

• PERFORMANCE

Maximum flow: 10 l/min.

Maximum Pressure:

- 210 bar (aluminium valves)
- 350 bar (steel valves)

Application range with standard springs:

- 5 + 50 bar; pressure increase= 4.8 bar/turn (test setting: 30 bar at 5 l/min.)
- 50 + 200 bar; pressure increase= 52 bar/turn (test setting: 150 bar at 5 l/min.) STANDARD
- 180 + 350 bar; pressure increase= 63 bar/turn (test setting: 250 bar at 5 l/min.)

Hysteresis: 90% of the valve setting for 1 L. flow capacity per minute.

To perform setting of the valve see the pressure drop / flow diagram.

Working temperature:

- min. -25°C max. 90°C with standard BUNAN gaskets
- min. -20°C max. 120°C with optional VITON gaskets.

Spare Parts KIT:

- Banjo bolt (Ordering code: 3BR3130510)
- External Seals for cartridges type MC08A (Ordering code: 5KT0082000)

• CROSS SECTION

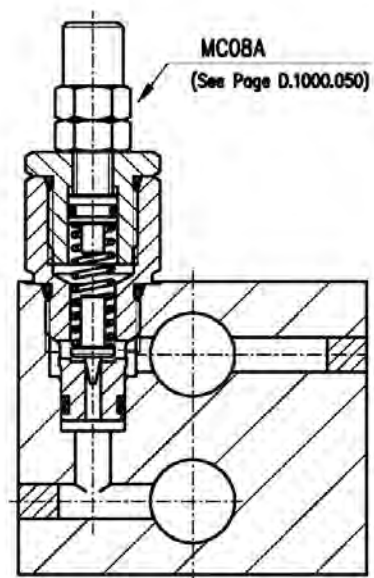

• RECOMMANDATIONS

Fluid: best use mineral oil with viscosity ranging between 10 and 200 cSt.

Filter: see General Informations

Weight:

- 0.9 kg aluminium valves

- 1,3 kg steel valves

Cartridge used: consult our Technical Department.

Material: internal components made out of high grade steel duly treated and fabricated.

For more information please ask our Technical Department.

Variations and modifications of technical features and dimensions are reserved. HANSA-TMP s.r.l. also reserves the right to stop production of each and any model listed in the catalogue with no notice.

Copyrights on the text contained herein belong to HANSA-TMP s.r.l. . Partial and full reproductions or copies of this catalogue are forbidden.

• RATING DIAGRAMS

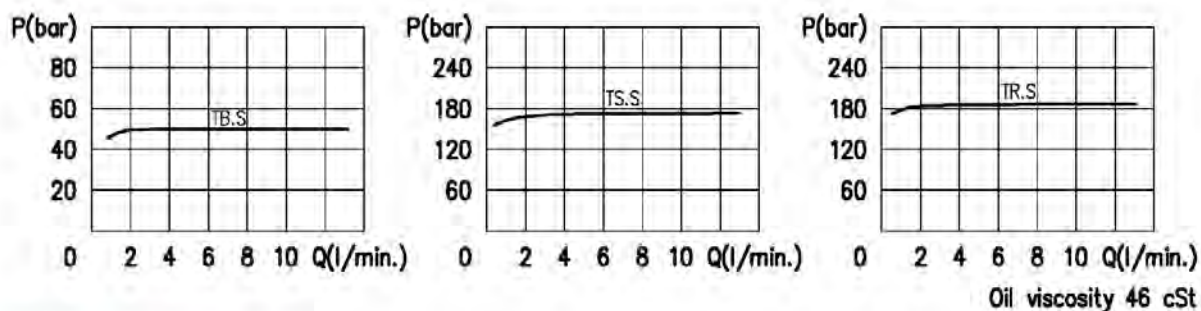

• ADJUSTMENTS

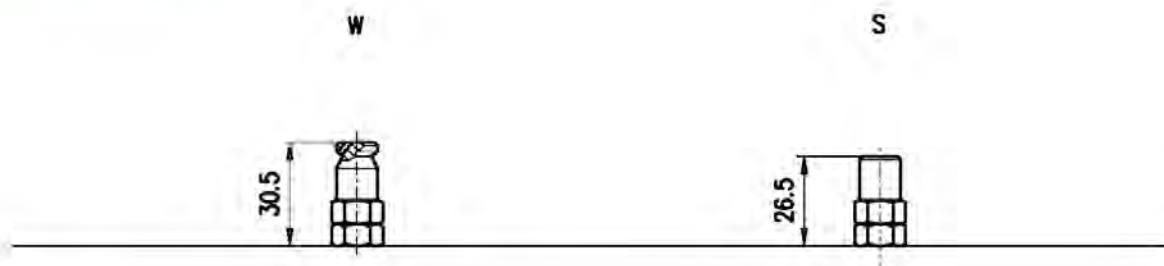

• CODE NUMBER

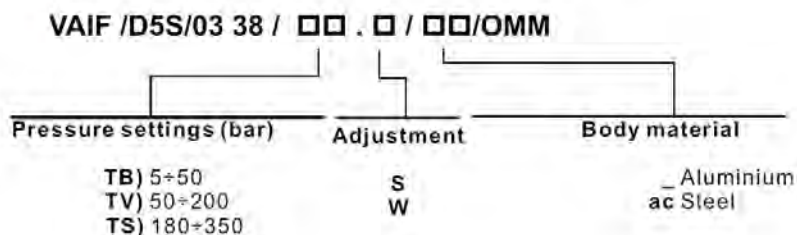

• DIMENSIONS (mm)

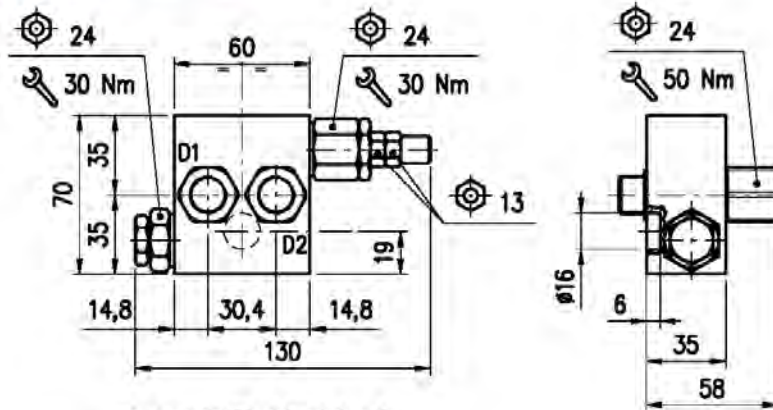

n° 4 WASHER 22x16,8x1,5
Cod. 4RD1161501

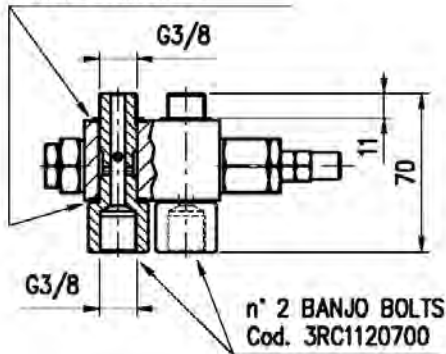

• HYDRAULIC DIAGRAM

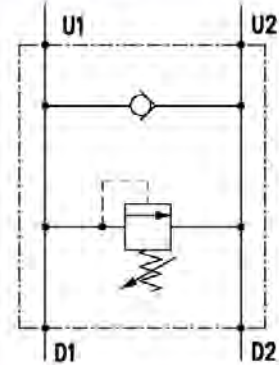

• ASSEMBLY DIAGRAM

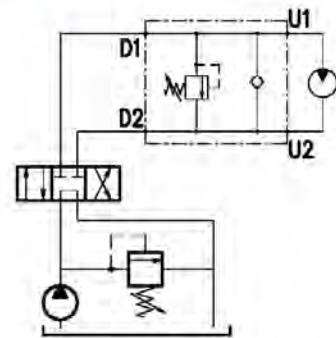

• DESCRIPTION

Single cross-line relief valve with anti cavitation. Direct acting, poppet type, face mounting for Sauer-Danfooss motor OMM series, including banjo bolts and washers

• OPERATION

Allows pressure relief on delivery pipes to engines and cylinders. When the actuator is braking, check valve allow for anti cavitation on delivery side.

• PERFORMANCE

Maximum flow: 10 l/min.

Maximum Pressure:

- 210 bar (aluminium valves)
- 350 bar (steel valves)

Application range with standard springs:

- 5 + 50 bar; pressure increase= 4.8 bar/turn (test setting: 30 bar at 5 l/min.)
- 50 + 200 bar; pressure increase= 52 bar/turn (test setting: 150 bar at 5 l/min.) STANDARD
- 180 + 350 bar; pressure increase= 63 bar/turn (test setting: 250 bar at 5 l/min.)

Hysteresis: 90% of the valve setting for 1 L. flow capacity per minute.

To perform setting of the valve see the pressure drop / flow diagram.

Working temperature:

- min. -25°C max. 90°C with standard BUNAN gaskets
- min. -20°C max. 120°C with optional VITON gaskets

Spare Parts KIT:

- A) Banjo bolt (Ordering code: 3RC1120700)
- B) External Seals for cartridges type MC08A and UC08A (Ordering code: 5KT0082000)

• CROSS SECTION

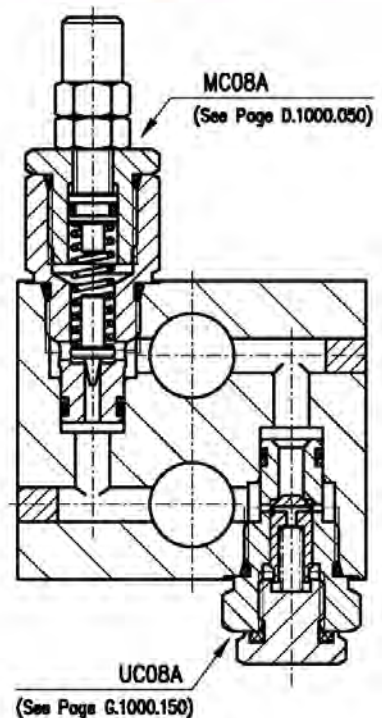

• RECOMMANDATIONS

Fluid: best use mineral oil with viscosity ranging between 10 and 200 cSt.

Filter: see General Informations

Weight:

- 0.9 kg aluminium valves

- 1,3 kg steel valves

Cartridge used: consult our Technical Department

Material: internal components made out of high grade steel duly treated and fabricated.

For more information please ask our Technical Department .

Variations and modifications of technical features and dimensions are reserved. HANSA-TMP s.r.l. also reserves the right to stop production of each and any model listed in the catalogue with no notice.

Copyrights on the text contained herein belong to HANSA-TMP s.r.l. . Partial and full reproductions or copies of this catalogue are forbidden.

• RATING DIAGRAMS

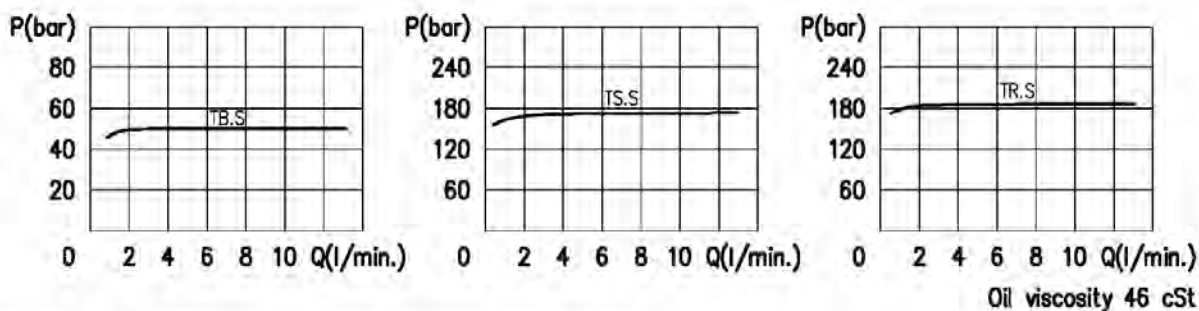

• ADJUSTMENTS



• CODE NUMBER

VAIF /D5S/VA/03 38 / □□ , □ / □□/OMM

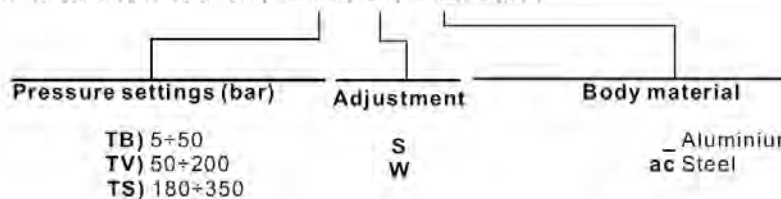

• DIMENSIONS (mm)

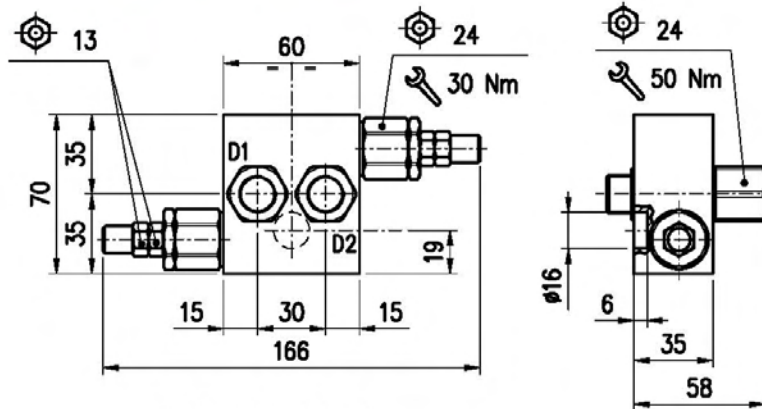

n° 4 WASHER 22x16,8x1,5
Cod. 4RD1161501

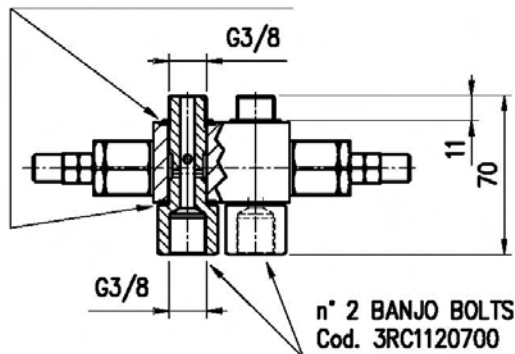

n° 2 BANJO BOLTS
Cod. 3RC1120700

• HYDRAULIC DIAGRAM

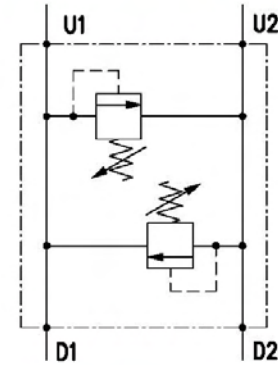

• ASSEMBLY DIAGRAM

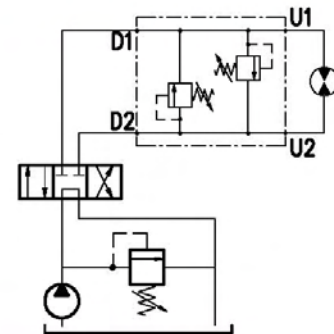

• DESCRIPTION

Dual cross-line relief valve. Direct acting, poppet type, face mounting for Sauer-Danfoss motor OMM series, including banjo bolts and washers

• OPERATION

Allows pressure relief on delivery pipes to engines and cylinders.

• PERFORMANCE

Maximum flow: 10 l/min.

Maximum Pressure:

- 210 bar (aluminium valves)
- 350 bar (steel valves)

Application range with standard springs:

- 5 + 50 bar; pressure increase= 4.8 bar/turn (test setting: 30 bar at 5 l/min.)
- 50 + 200 bar; pressure increase= 52 bar/turn (test setting: 150 bar at 5 l/min.) STANDARD
- 180 + 350 bar; pressure increase= 63 bar/turn (test setting: 250 bar at 5 l/min.)

Hysteresis: 90% of the valve setting for 1 L. flow capacity per minute.

To perform setting of the valve see the pressure drop / flow diagram.

Working temperature:

- min. -25°C max. 90°C with standard BUNAN gaskets
- min. -20°C max. 120°C with optional VITON gaskets

Spare Parts KIT:

- Banjo bolt (Ordering code: 3RC1120700)
- External Seals for cartridges type MC08A (Ordering code: 5KT0082000)

• RECOMMANDATIONS

Fluid: best use mineral oil with viscosity ranging between 10 and 200 cSt.

• CROSS SECTION

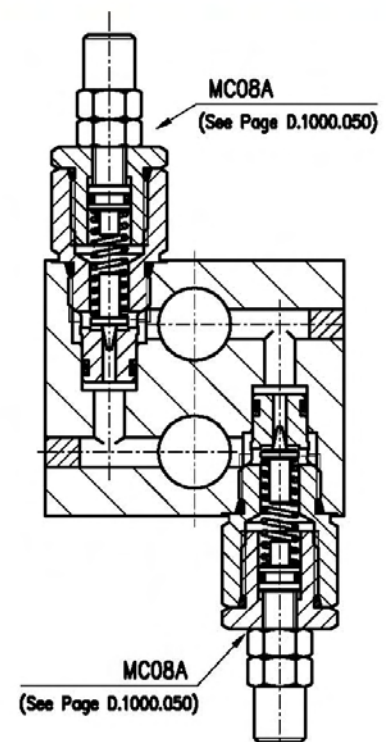

Filter: see General Informations

Weight:

- 1 kg aluminium valves
- 1,4 kg steel valves

Cartridge used: consult our Technical Department

Material: internal components made out of high grade steel duly treated and fabricated.

For more information please ask our Technical Department .

Variations and modifications of technical features and dimensions are reserved. HANSA-TMP s.r.l. also reserves the right to stop production of each and any model listed in the catalogue with no notice.

Copyrights on the text contained herein belong to HANSA-TMP s.r.l.. Partial and full reproductions or copies of this catalogue are forbidden.

• **RATING DIAGRAMS**

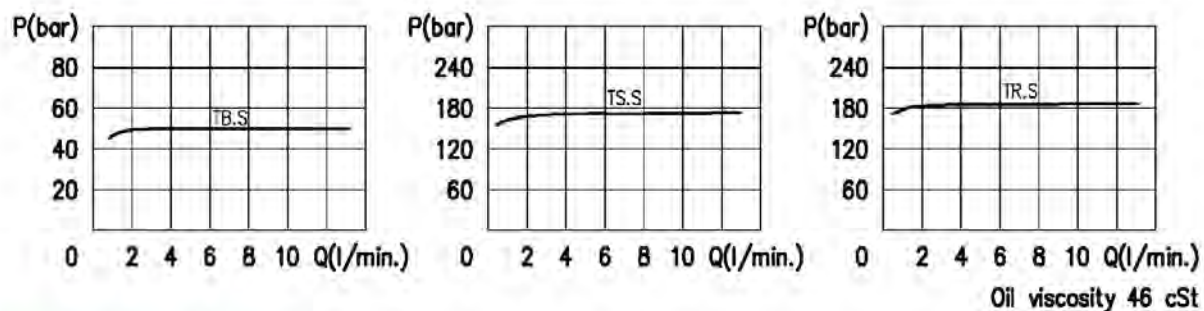

• **ADJUSTMENTS**



• **CODE NUMBER**

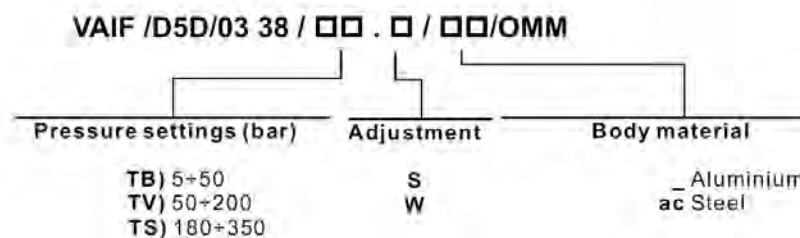

• DIMENSIONS (mm)

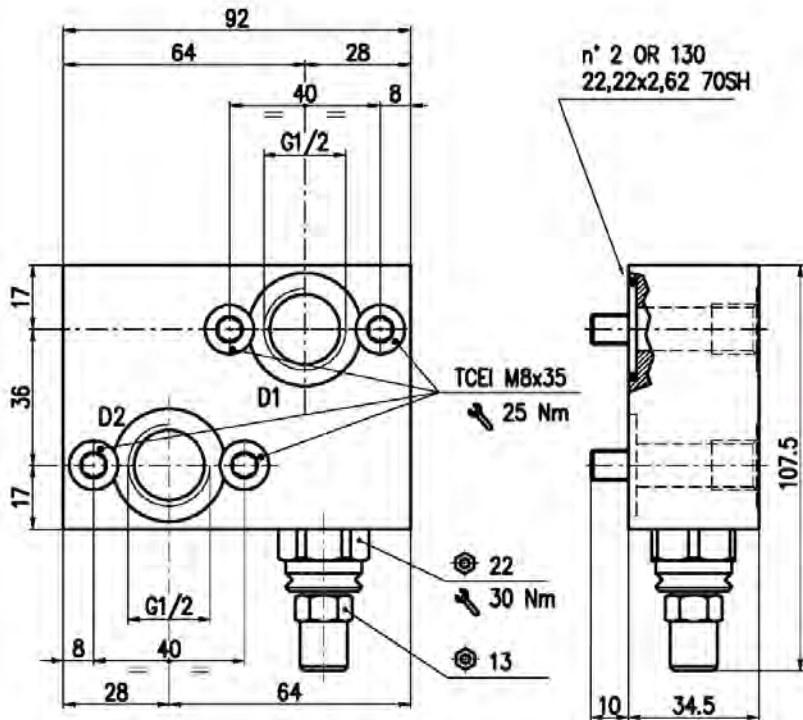

• HYDRAULIC DIAGRAM

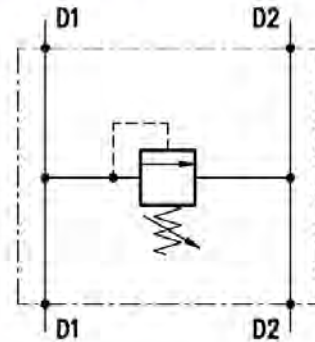

• ASSEMBLY DIAGRAM

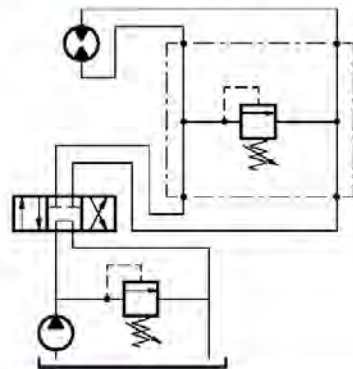

• DESCRIPTION

Single cross-line relief valve. Direct acting, poppet type, face mounting for Sauer-Danfoss motor OMP-OMPL-OMR series, including O-rings and screws

• OPERATION

Allows pressure relief on delivery pipes to engines and cylinders.

• PERFORMANCE

Maximum flow: 50 l/min.

Maximum Pressure:

- 210 bar (aluminium valves)
- 350 bar (steel valves)

Application range with standard springs:

- 0 + 80 bar; pressure increase= 12 bar/turn (test setting: 20 bar at 5 l/min.)
- 50 + 130 bar; pressure increase= 19,5 bar/turn (test setting: 60 bar at 5 l/min.)
- 120 + 250 bar; pressure increase= 37.5 bar/turn (test setting: 150 bar at 5 l/min.) STANDARD

Hysteresis: 90% of the valve setting for 1 L. flow capacity per minute.

To perform setting of the valve see the pressure drop / flow diagram.

Working temperature:

- min. -25°C max. 90°C with standard BUNAN gaskets
- min. -20°C max. 120°C with optional VITON gaskets

Spare Parts KIT:

Screws and Seals (Ordering code: 5KTM00MR00)

• CROSS SECTION

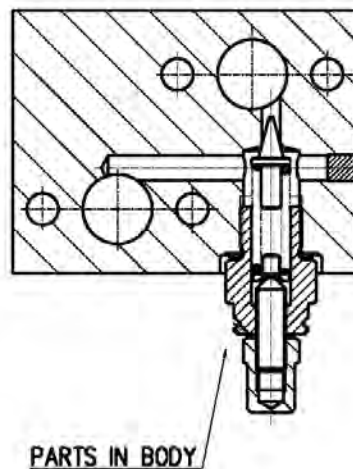

• RECOMMANDATIONS

Fluid: best use mineral oil with viscosity ranging between 10 and 200 cSt.

Filter: see General Informations

Weight:

- 0.7 kg aluminium valves

- 1.3 kg steel valves

Cartridge used : **consult our Technical Department.**

Material: internal components made out of high grade steel duly treated and fabricated.

For more information please ask our Technical Department .

Variations and modifications of technical features and dimensions are reserved. HANSA-TMP s.r.l. also reserves the right to stop production of each and any model listed in the catalogue with no notice.

Copyrights on the text contained herein belong to HANSA-TMP s.r.l.. Partial and full reproductions or copies of this catalogue are forbidden.

• RATING DIAGRAMS

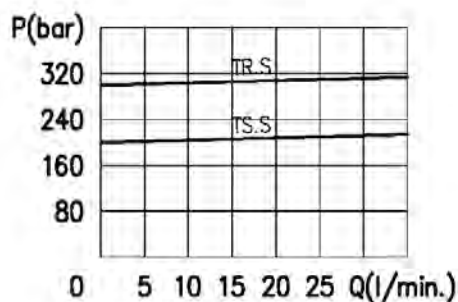
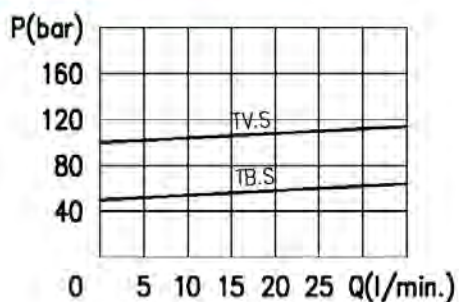

Oil viscosity 46 cSt

• ADJUSTMENTS



• CODE NUMBER

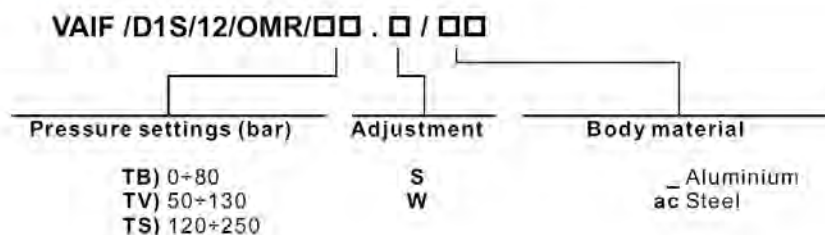

• DIMENSIONS (mm)

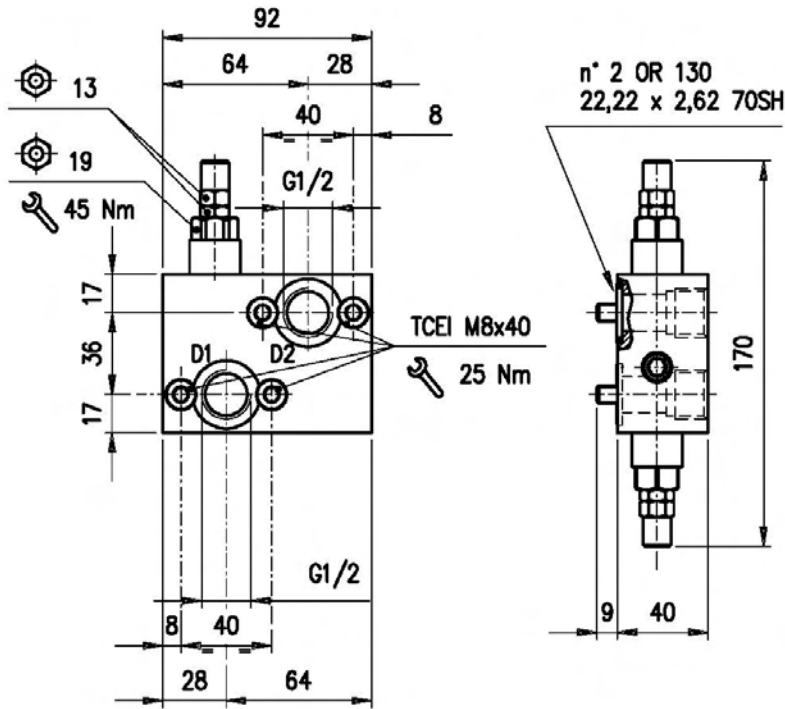

• HYDRAULIC DIAGRAM

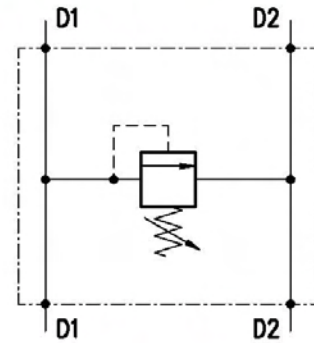

• ASSEMBLY DIAGRAM

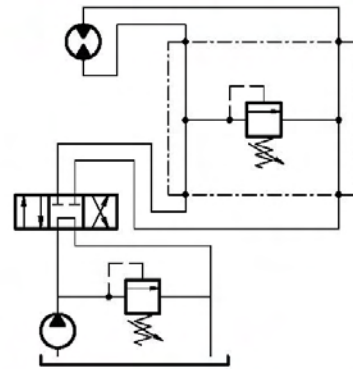

• DESCRIPTION

Single cross-line relief valve. Direct acting, poppet type, face mounting for Sauer-Danfoss motor OMR series, including O-rings and screws

• OPERATION

Allows pressure relief on delivery pipes to engines and cylinders.

• PERFORMANCE

Maximum flow: 35 l/min.

Maximum Pressure:

- 210 bar (aluminium valves)
- 350 bar (steel valves)

Application range with standard springs:

- 5 + 40 bar; pressure increase= 4.8 bar/turn (test setting: 30 bar at 5 l/min.)
- 20 + 80 bar; pressure increase= 15.6 bar/turn (test setting: 60 bar at 5 l/min.)
- 50 + 220 bar; pressure increase= 52 bar/turn (test setting: 160 bar at 5 l/min.) STANDARD
- 180 + 350 bar; pressure increase= 63 bar/turn (test setting: 280 bar at 5 l/min.)

Hysteresis: 85% of the valve setting for 1 L. flow capacity per minute.

To perform setting of the valve see the pressure drop / flow diagram.

Working temperature:

- min. -25°C max. 90°C with standard BUNAN gaskets
- min. -20°C max. 120°C with optional VITON gaskets

Spare Parts KIT:

Screws and Seals (Ordering code: 5KTM00MR01)

• CROSS SECTION

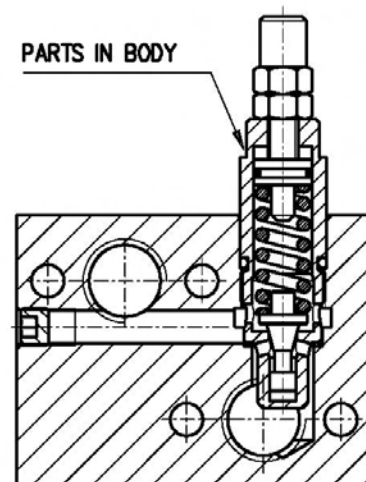

RECOMMENDATIONS

Fluid: best use mineral oil with viscosity ranging between 10 and 200 cSt.

Filter: see General Informations.

Weight:

- 0,45 kg aluminium valves
- 0,9 kg steel valves

Cartridge used : consult our Technical Department.

Material: internal components made out of high grade steel duly treated and fabricated.

For more information please ask our Technical Department .

Variations and modifications of technical features and dimensions are reserved. HANSA-TMP s.r.l. also reserves the right to stop production of each and any model listed in the catalogue with no notice.

Copyrights on the text contained herein belong to HANSA-TMP s.r.l.. Partial and full reproductions or copies of this catalogue are forbidden.

• RATING DIAGRAMS

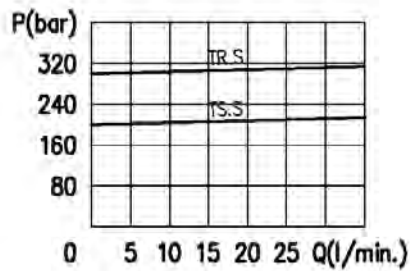
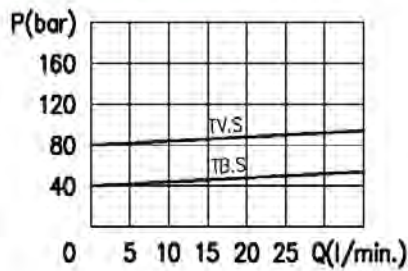

Oil viscosity 46 cSt

• ADJUSTMENTS

W

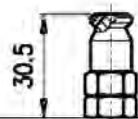

S

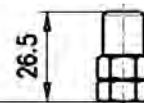

• CODE NUMBER

VAIF 5/D1S/ 12/OMR/ □□ . □ / □□

Pressure settings (bar)

Adjustment

Body material

- TB) 5÷40
- TV) 20÷80
- TS) 50÷220
- TR) 180÷350

- S
- W

- Aluminium
- ac Steel

• DIMENSIONS (mm)

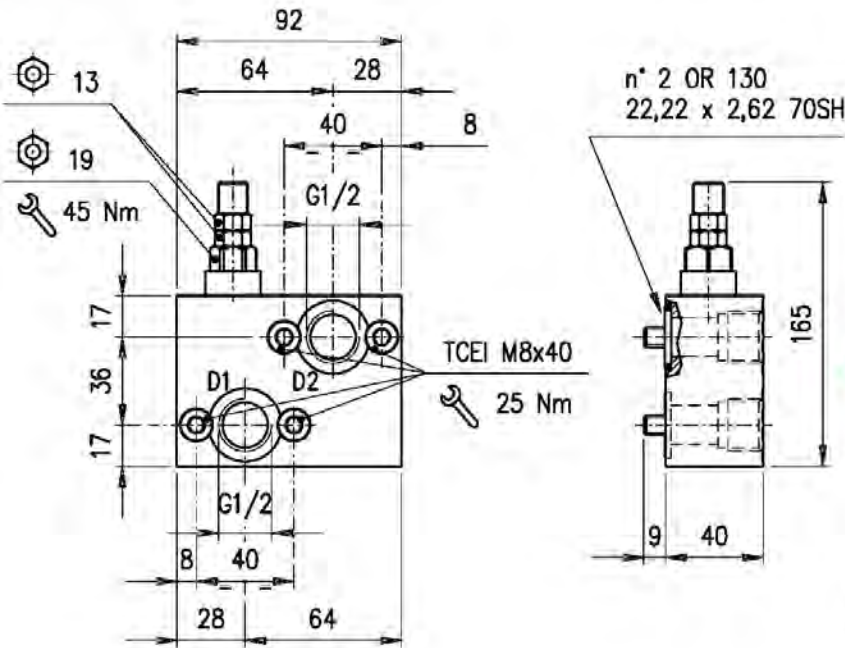

• HYDRAULIC DIAGRAM

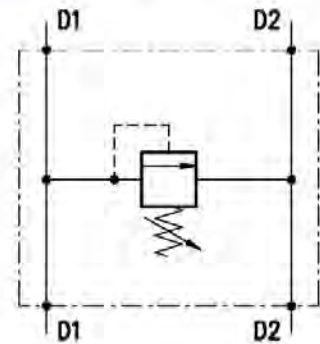

• ASSEMBLY DIAGRAM

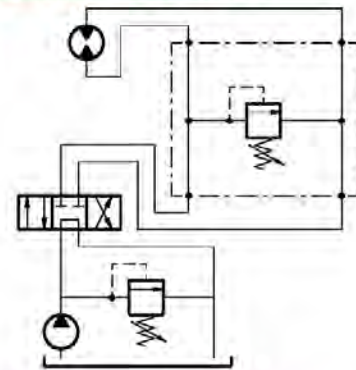

• DESCRIPTION

Single cross-line relief valve. Direct acting, poppet type, face mounting for Sauer-Danfoss motor OMS series, including O-rings and screws

• OPERATION

Allows pressure relief on delivery pipes to engines and cylinders.

• PERFORMANCE

Maximum flow: 35 l/min.

Maximum Pressure:

- 210 bar (aluminium valves)

- 350 bar (steel valves)

Application range with standard springs:

- 5 ÷ 80 bar; pressure increase = 9,4 bar/turn (test setting: 60 bar at 5 l/min.)

- 40 ÷ 150 bar; pressure increase = 30,5 bar/turn (test setting: 120 bar at 5 l/min.)

- 140 ÷ 190 bar; pressure increase = 40,4 bar/turn (test setting: 150 bar at 5 l/min.) STANDARD

- 180 ÷ 350 bar; pressure increase = 101 bar/turn (test setting: 260 bar at 5 l/min.)

Hysteresis: 85% of the valve setting for 1 L, flow capacity per minute

To perform setting of the valve see the pressure drop / flow diagram,

Working temperature:

- min. -25°C max. 90°C with standard BUNAN gaskets

- min. -20°C max. 120°C with optional VITON gaskets

Spare Parts KIT:

Screws and Seals (Ordering code: 5KTM00MR00)

• CROSS SECTION

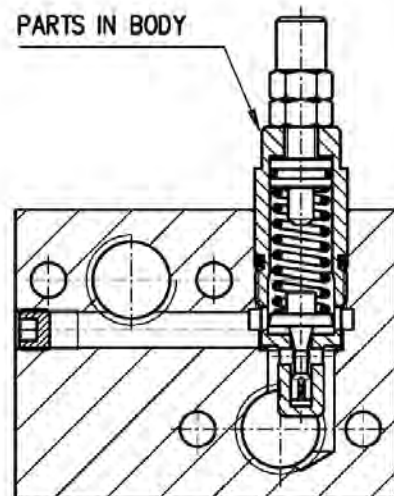

RECOMMENDATIONS

Fluid: best use mineral oil with viscosity ranging between 10 and 200 cSt.

Filter: see General Informations.

Weight:

- 0,45 kg aluminium valves

- 0,9 kg steel valves

Cartridge used: consult our Technical Department.

Material: internal components made out of high grade steel duly treated and fabricated.

For more information please ask our Technical Department .

Variations and modifications of technical features and dimensions are reserved. HANSA-TMP s.r.l. also reserves the right to stop production of each and any model listed in the catalogue with no notice.

Copyrights on the text contained herein belong to HANSA-TMP s.r.l.. Partial and full reproductions or copies of this catalogue are forbidden.

• RATING DIAGRAMS

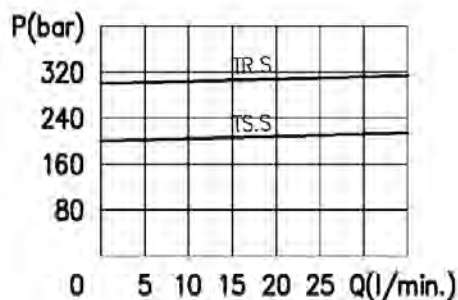
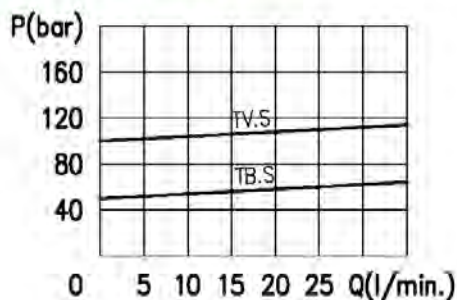

Oil viscosity 46 cSt

• ADJUSTMENTS

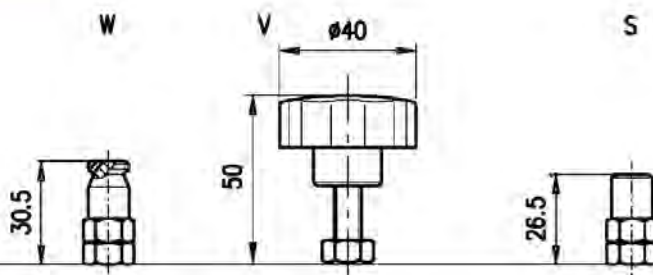

• CODE NUMBER

VAIF 5Y /D1S/ 12/ OMR / □□ . □ / □□

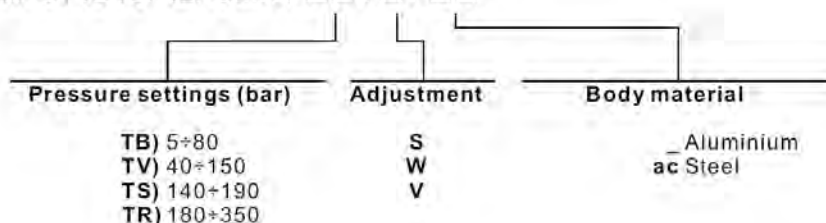

• DIMENSIONS (mm)

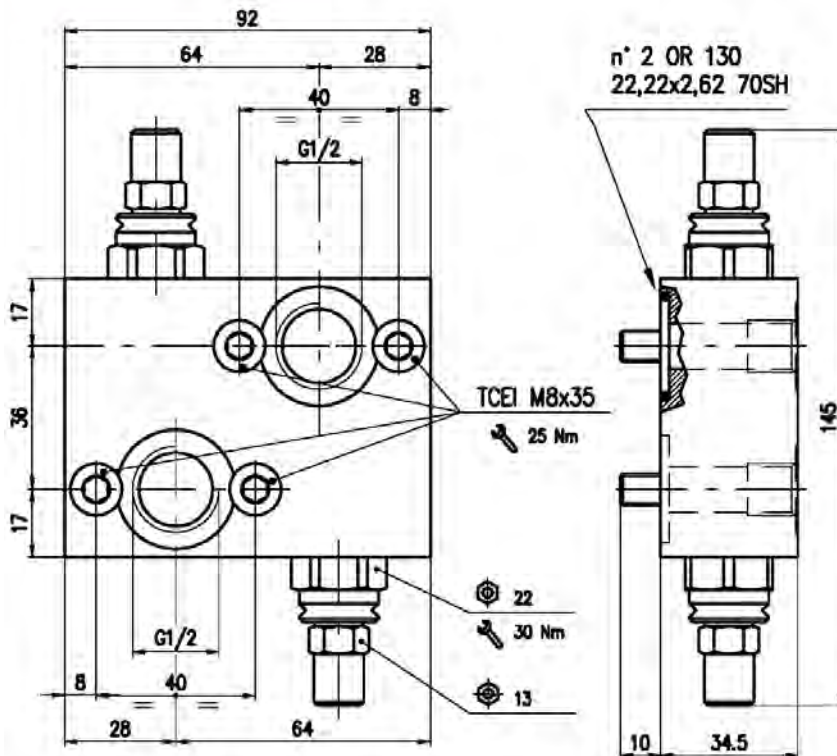

• HYDRAULIC DIAGRAM

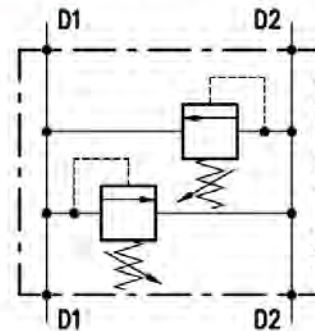

• ASSEMBLY DIAGRAM

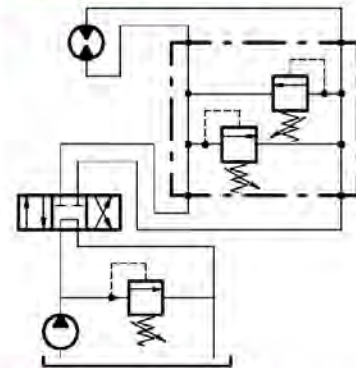

• DESCRIPTION

Dual cross-line relief valve. Direct acting, poppet type, face mounting for Sauer-Danfoss motor OMP-OMPL-OMR series, including O-rings and screws.

• OPERATION

Allows pressure relief on delivery pipes to engines and cylinders.

• PERFORMANCE

Maximum flow: 50 l/min.

Maximum Pressure:

- 210 bar (aluminium valves)
- 350 bar (steel valves)

Application range with standard springs:

- 0 ÷ 80 bar; pressure increase= 12 bar/turn (test setting: 20 bar at 5 l/min.)
- 50 ÷ 130 bar; pressure increase= 19.5 bar/turn (test setting: 60 bar at 5 l/min.)
- 120 ÷ 250 bar; pressure increase= 37.5 bar/turn (test setting: 150 bar at 5 l/min.) STANDARD

Hysteresis: 90% of the valve setting for 1 L. flow capacity per minute.

To perform setting of the valve see the pressure drop / flow diagram.

Working temperature:

- min. -25°C max. 90°C with standard BUNAN gaskets
- min. -20°C max. 120°C with optional VITON gaskets

Spare Parts KIT: Screws and Seals (Ordering code: 5KTM00MR00)

• CROSS SECTION

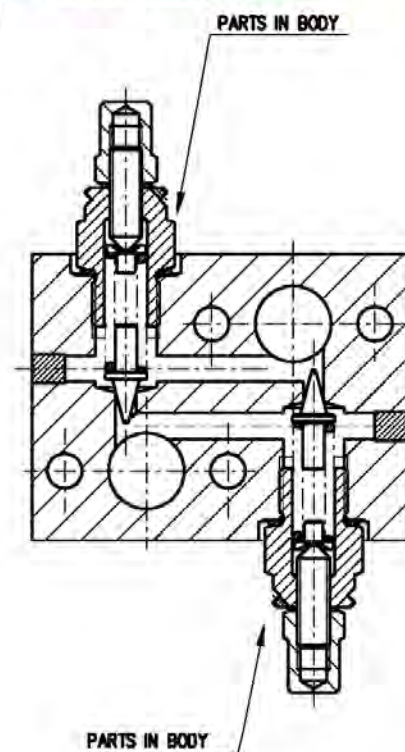

• RECOMMENDATIONS

Fluid: best use mineral oil with viscosity ranging between 10 and 200 cSt.

Filter: see General Informations.

Weight:

- 0.9 kg aluminium valves

- 1.5 kg steel valves

Cartridge used: consult our Technical Department.

Material: internal components made out of high grade steel duly treated and fabricated.

For more information please ask our Technical Department .

Variations and modifications of technical features and dimensions are reserved. HANSA-TMP s.r.l. also reserves the right to stop production of each and any model listed in the catalogue with no notice.

Copyrights on the text contained herein belong to HANSA-TMP s.r.l.. Partial and full reproductions or copies of this catalogue are forbidden.

• **RATING DIAGRAMS**

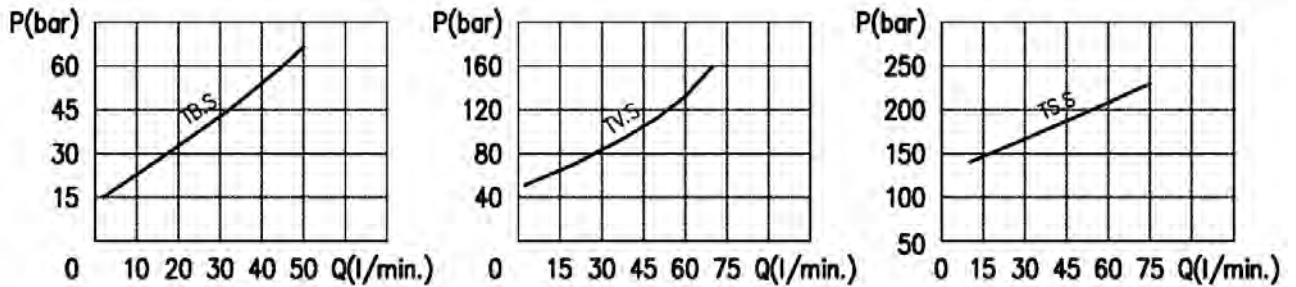

• **ADJUSTMENTS**



• **CODE NUMBER**

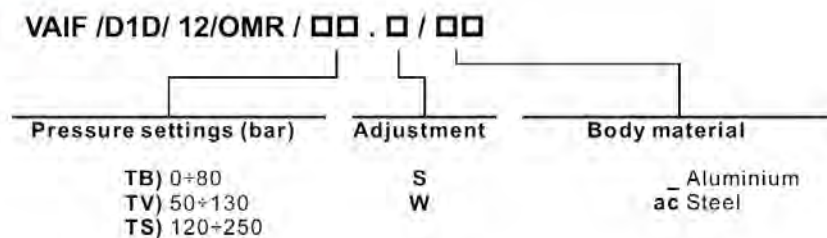

• DIMENSIONS (mm)

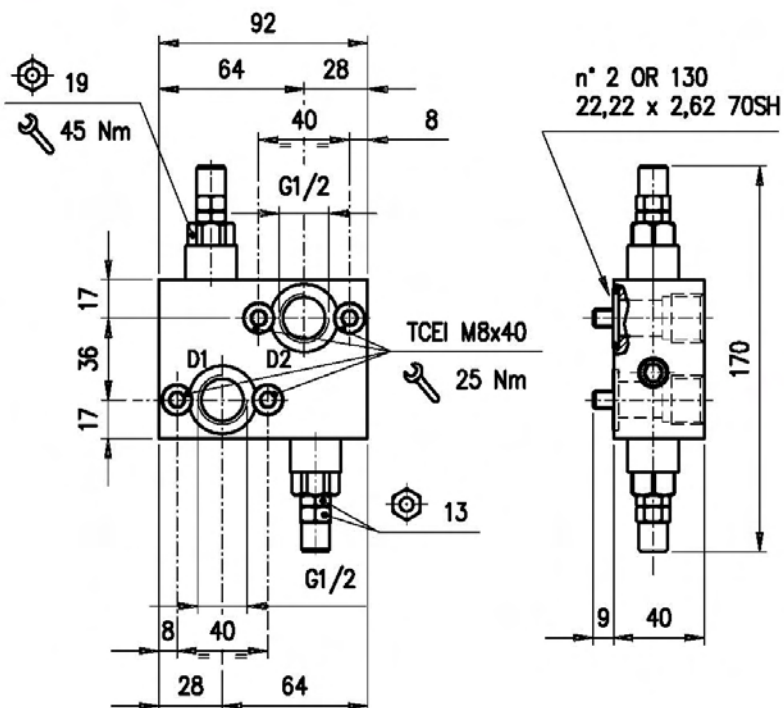

• HYDRAULIC DIAGRAM

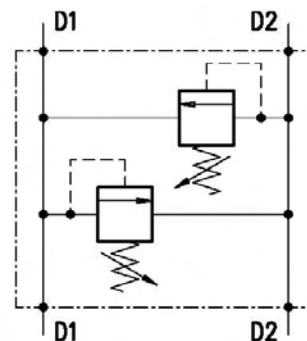

• ASSEMBLY DIAGRAM

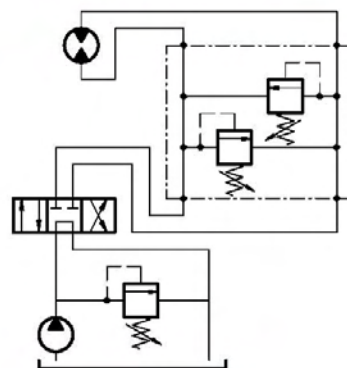

• DESCRIPTION

Dual cross-line relief valve. Direct acting, poppet type, face mounting for Sauer-Danfoss motor OMP-OMPL-OMR series, including O-rings and screws

• OPERATION

Allows pressure relief on delivery pipes to engines and cylinders.

• PERFORMANCE

Maximum flow: 35 l/min.

Maximum Pressure:

- 210 bar (aluminium valves)
- 350 bar (steel valves)

Application range with standard springs:

- 5 + 40 bar; pressure increase= 4.8 bar/turn (test setting: 30 bar at 5 l/min.)
- 20 + 80 bar; pressure increase= 15.6 bar/turn (test setting: 60 bar at 5 l/min.)
- 50 + 220 bar; pressure increase= 52 bar/turn (test setting: 160 bar at 5 l/min.) STANDARD
- 180 + 350 bar; pressure increase= 63 bar/turn (test setting: 280 bar at 5 l/min.)

Hysteresis: 85% of the valve setting for 1 L. flow capacity per minute.

To perform setting of the valve see the pressure drop / flow diagram.

Working temperature:

- min. -25°C max. 90°C with standard BUNAN gaskets
- min. -20°C max. 120°C with optional VITON gaskets

Spare Parts KIT:

Screws and Seals (Ordering code: 5KTM00MR01)

• CROSS SECTION

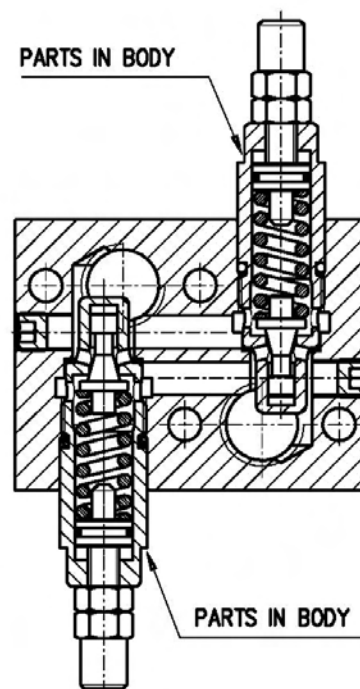

RECOMMENDATIONS

Fluid: best use mineral oil with viscosity ranging between 10 and 200 cSt.

Filter: see General Informations.

Weight:

- 0.55 kg aluminium valves

- 1 kg steel valves

Cartridge used: consult our Technical Department.

Material: internal components made out of high grade steel duly treated and fabricated.

For more information please ask our Technical Department .

Variations and modifications of technical features and dimensions are reserved. HANSA-TMP s.r.l. also reserves the right to stop production of each and any model listed in the catalogue with no notice.

Copyrights on the text contained herein belong to HANSA-TMP s.r.l.. Partial and full reproductions or copies of this catalogue are forbidden.

• RATING DIAGRAMS

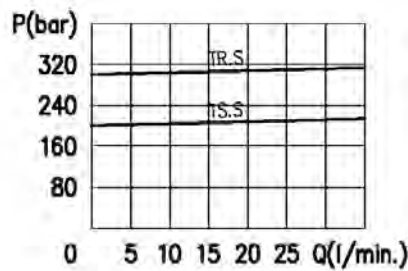
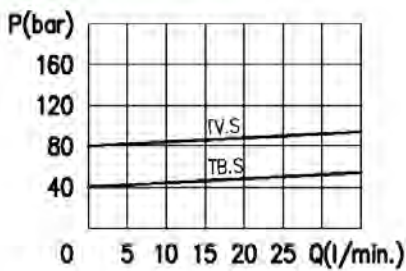

Oil viscosity 46 cSt

• ADJUSTMENTS

W

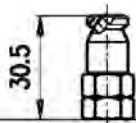

S

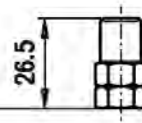

• CODE NUMBER

VAIF 5/D1D/ 12/OMR/□□ . □ / □□

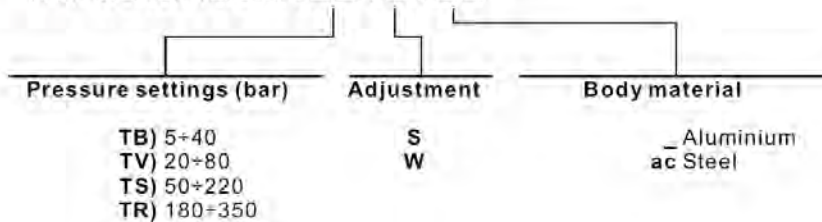

• DIMENSIONS (mm)

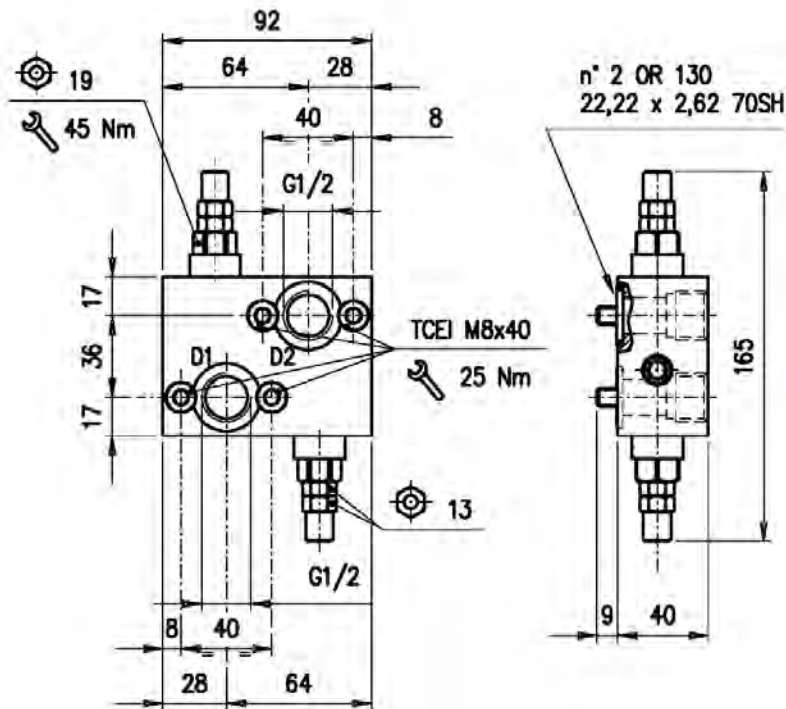

• HYDRAULIC DIAGRAM

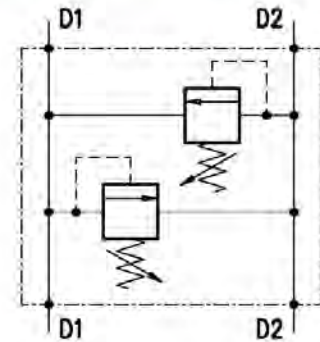

• ASSEMBLY DIAGRAM

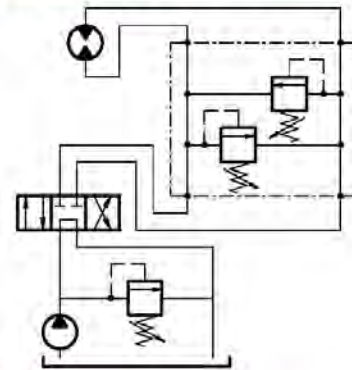

• DESCRIPTION

Dual cross-line relief valve. Direct acting, poppet type, face mounting for Sauer-Danfoss motor OMS series, including O-rings and screws.

• OPERATION

Allows pressure relief on delivery pipes to engines and cylinders.

• PERFORMANCE

Maximum flow: 35 l/min.

Maximum Pressure:

- 210 bar (aluminium valves)
- 350 bar (steel valves)

Application range with standard springs:

- 5 ÷ 80 bar; pressure increase= 9,4 bar/turn (test setting: 60 bar at 5 l/min.)
- 40 ÷ 150 bar; pressure increase= 30,5 bar/turn (test setting: 120 bar at 5 l/min.)
- 140 ÷ 190 bar; pressure increase= 40,4 bar/turn (test setting: 150 bar at 5 l/min.) STANDARD
- 180 ÷ 350 bar; pressure increase= 101 bar/turn (test setting: 260 bar at 5 l/min.)

Hysteresis: 85% of the valve setting for 1 L. flow capacity per minute.

To perform setting of the valve see the pressure drop / flow diagram.

Working temperature:

- min. -25°C max. 90°C with standard BUNAN gaskets
- min. -20°C max. 120°C with optional VITON gaskets

Spare Parts KIT:

A) Screws and Seals (Ordering code: 5KTM00MR01)

• CROSS SECTION

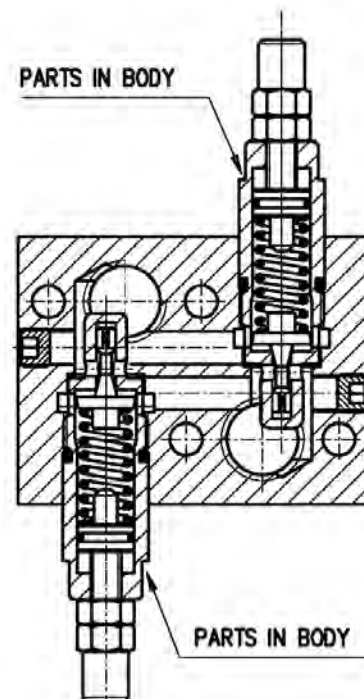

• **RECOMMANDATIONS**

Fluid: best use mineral oil with viscosity ranging between 10 and 200 cSt.

Filter: see General Informations.

Weight:

- 0.55 kg aluminium valves

- 1 kg steel valves

Cartridge used: consult our Technical Department.

Material: internal components made out of high grade steel duly treated and fabricated.

For more information please ask our Technical Department.

Variations and modifications of technical features and dimensions are reserved. HANSA-TMP s.r.l. also reserves the right to stop production of each and any model listed in the catalogue with no notice.

Copyrights on the text contained herein belong to HANSA-TMP s.r.l.. Partial and full reproductions or copies of this catalogue are forbidden.

• **RATING DIAGRAMS**

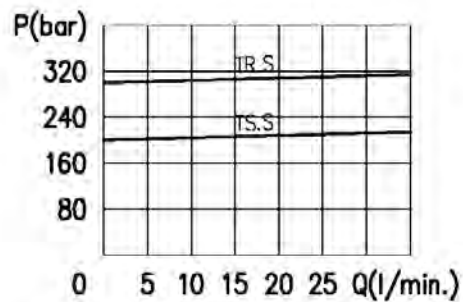
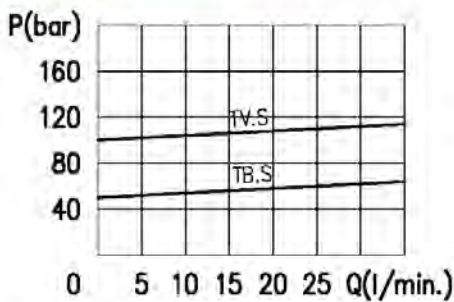

Oil viscosity 46 cSt

• **ADJUSTMENTS**



• **CODE NUMBER**

VAIF /5Y/D1D/12/OMR / □□ , □ / □□

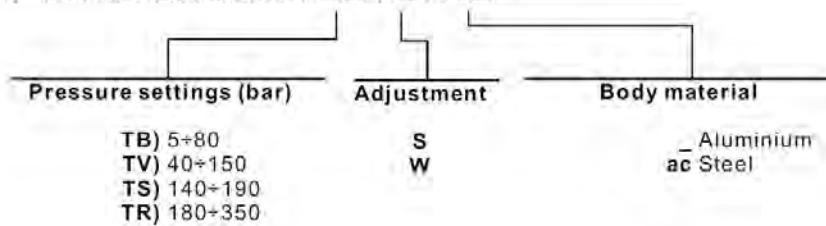

• DIMENSIONS (mm)

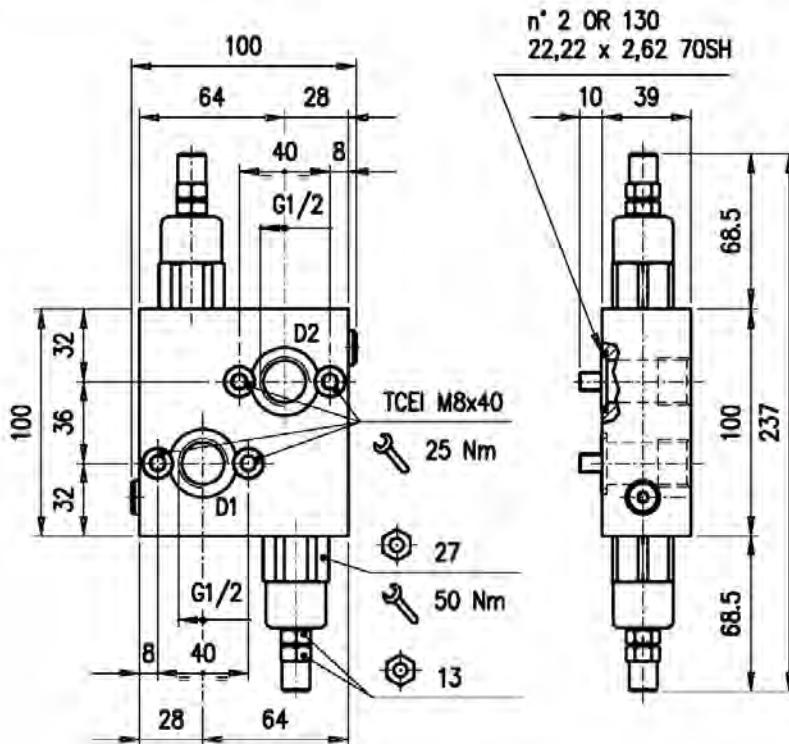

• HYDRAULIC DIAGRAM

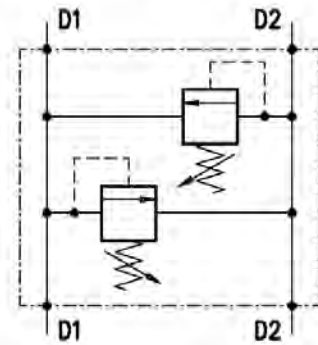

• ASSEMBLY DIAGRAM

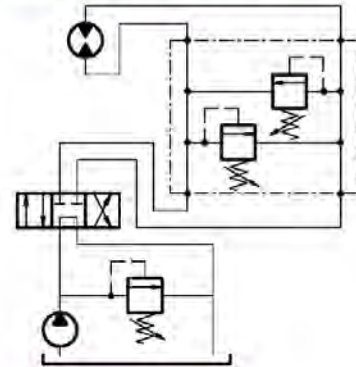

• DESCRIPTION

Dual cross-line relief valve. Direct acting, poppet type, face mounting for Sauer-Danfoss motor OMS series, including O-rings and screws

• OPERATION

Allows pressure relief on delivery pipes to engines and cylinders.

• PERFORMANCE

Maximum flow: 60 l/min.

Maximum Pressure:

- 210 bar (aluminium valves)
- 350 bar (steel valves)

Application range with standard springs:

- 5 + 40 bar; pressure increase= 5,2bar/turn (test setting: 30 bar at 5 l/min.)
- 20 + 80 bar; pressure increase= 6,6 bar/turn (test setting: 60 bar at 5 l/min.)
- 50 + 220 bar; pressure increase= 58,3 bar/turn (test setting: 160 bar at 5 l/min.) STANDARD
- 180 + 350 bar; pressure increase= 73,1 bar/turn (test setting: 280 bar at 5 l/min.)

Hysteresis: 85% of the valve setting for 1 L. flow capacity per minute.

To perform setting of the valve see the pressure drop / flow diagram.

Working temperature:

- min. -25°C max. 90°C with standard BUNAN gaskets
- min. -20°C max. 120°C with optional VITON gaskets

Spare Parts KIT:

Screws and Seals (Ordering code: 5KTM00MR01)

• CROSS SECTION

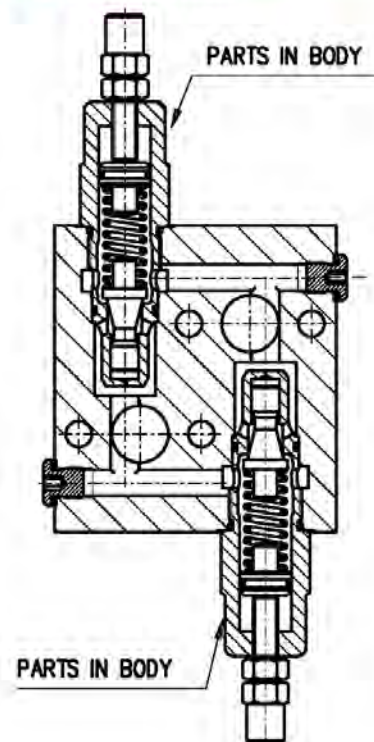

• RECOMMANDATIONS

Fluid: best use mineral oil with viscosity ranging between 10 and 200 cSt.

Filter: see General Informations.

Weight:

- 0.8 kg aluminium valves

- 1.4 kg steel valves

Cartridge used: consult our Technical Department.

Material: internal components made out of high grade steel duly treated and fabricated.

For more information please ask our Technical Department .

Variations and modifications of technical features and dimensions are reserved. HANSA-TMP s.r.l. also reserves the right to stop production of each and any model listed in the catalogue with no notice.

Copyrights on the text contained herein belong to HANSA-TMP s.r.l.. Partial and full reproductions or copies of this catalogue are forbidden.

• RATING DIAGRAMS

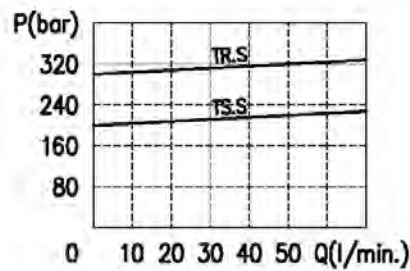
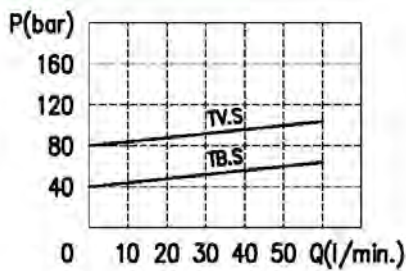

Oil viscosity 46 cSt

• ADJUSTMENTS

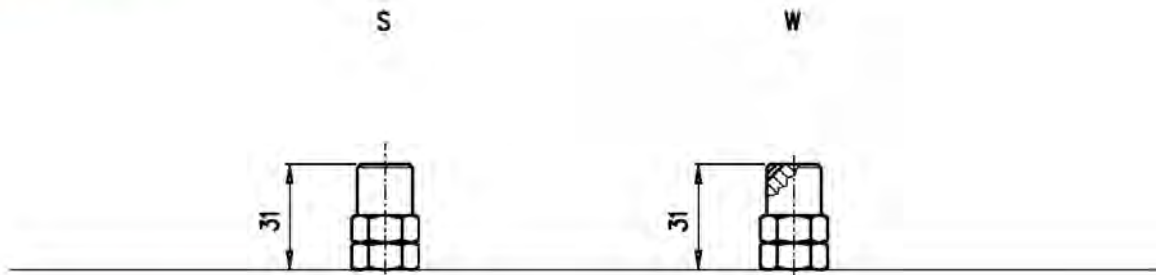

• CODE NUMBER

VAIF 10/D1D/ 12/OMR/□□ . □ / □□

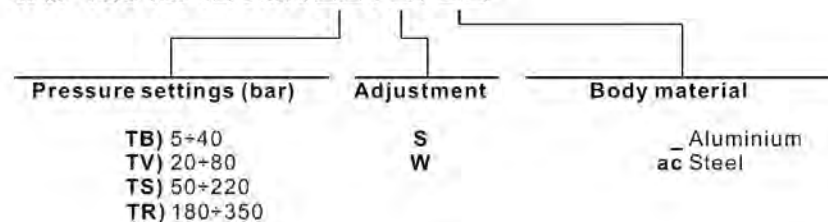

• DIMENSIONS (mm)

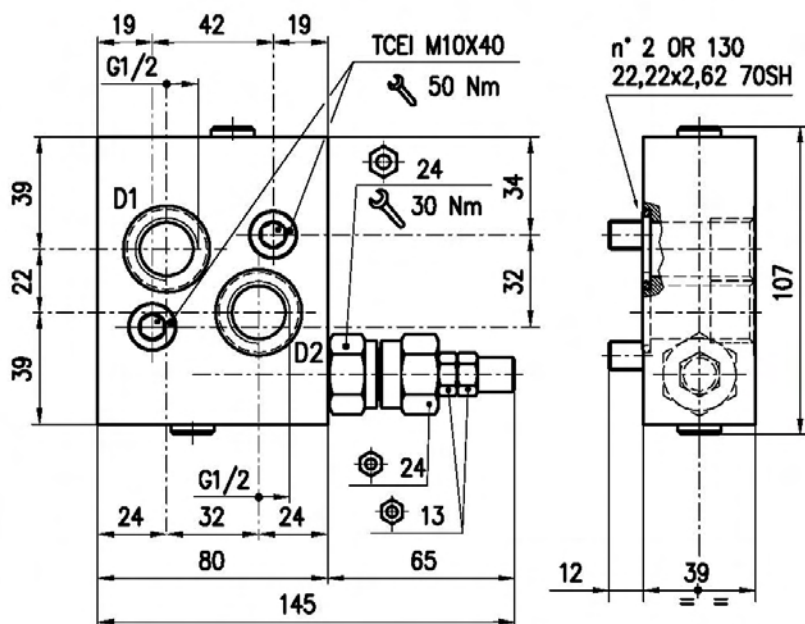

• HYDRAULIC DIAGRAM

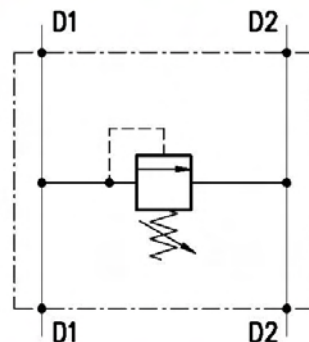

• ASSEMBLY DIAGRAM

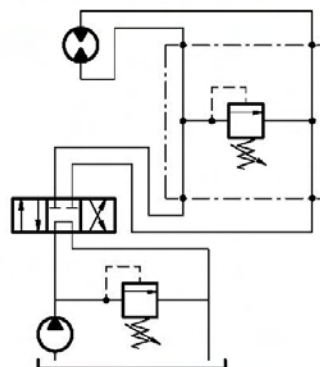

• DESCRIPTION

Single cross-line relief valve. Direct acting, poppet type, face mounting for Sauer-Danfoss motor OMS series, including O-rings and screws

• OPERATION

Allows pressure relief on delivery pipes to engines and cylinders.

PERFORMANCE

Maximum flow: 35 l/min.

Maximum Pressure:

- 210 bar (aluminium valves)

- 350 bar (steel valves)

Application range with standard springs:

- 5 + 40 bar; pressure increase= 1.59 bar/turn (test setting: 30 bar at 5 l/min.)

- 20 + 80 bar; pressure increase= 7.03 bar/turn (test setting: 60 bar at 5 l/min.)

- 50 + 220 bar; pressure increase= 24.15 bar/turn (test setting: 160 bar at 5 l/min.) STANDARD

- 180 + 350 bar; pressure increase= 72.24 bar/turn (test setting: 250 bar at 5 l/min.)

Hysteresis: 85% of the valve setting for 1 L. flow capacity per minute.

To perform setting of the valve see the pressure drop / flow diagram.

Working temperature:

- min. -25°C max. 90°C with standard BUNAN gaskets

- min. -20°C max. 120°C with optional VITON gaskets

Spare Parts KIT:

- Screws and Seals (Ordering code: 5KTM0OMS00)

- External Seals for cartridges type VMP 12 (Ordering code: 5KT1000301)

• CROSS SECTION

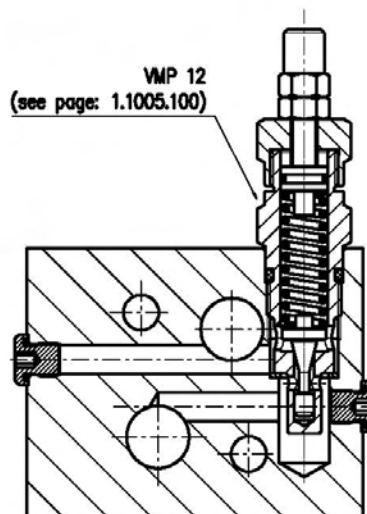

• RECOMMANDATIONS

Fluid: best use mineral oil with viscosity ranging between 10 and 200 cSt.

Filter: see General Informations.

Weight:

- 0.6 kg aluminium valves

- 1.2 kg steel valves

Cartridge used: consult our Technical Department.

Material: internal components made out of high grade steel duly treated and fabricated.

For more information please ask our Technical Department .

Variations and modifications of technical features and dimensions are reserved. HANSA-TMP s.r.l. also reserves the right to stop production of each and any model listed in the catalogue with no notice.

Copyrights on the text contained herein belong to HANSA-TMP s.r.l.. Partial and full reproductions or copies of this catalogue are forbidden.

• RATING DIAGRAMS

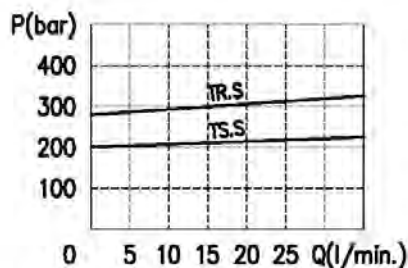
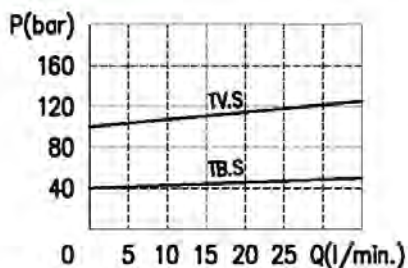

Oil viscosity 46 cSt

• ADJUSTMENTS

S

W

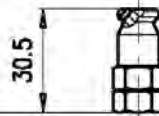
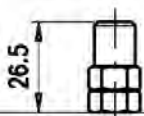

• CODE NUMBER

VAIF 12/S12/ OMS / □□ . □ / □□

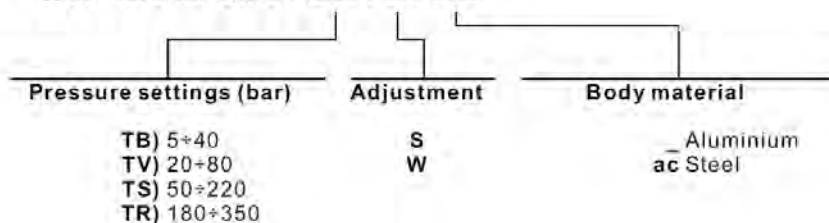

• DIMENSIONS (mm)

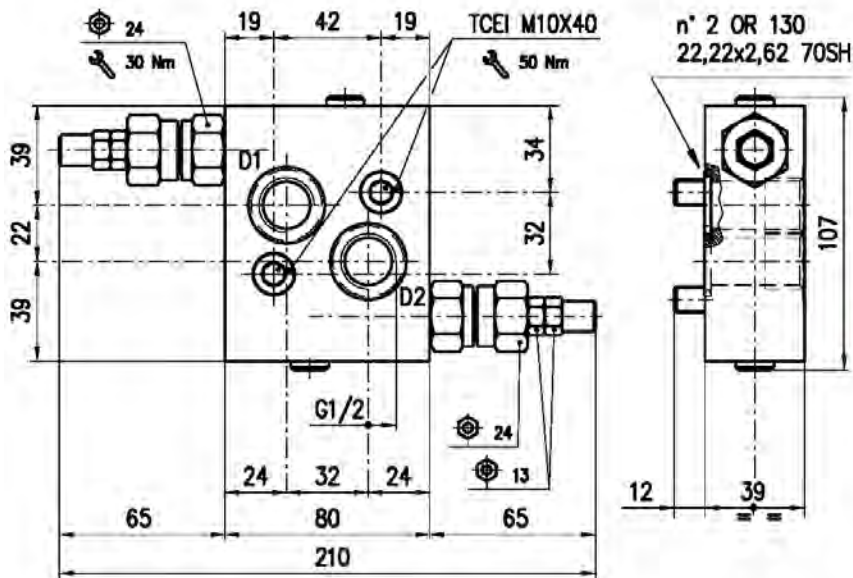

• HYDRAULIC DIAGRAM

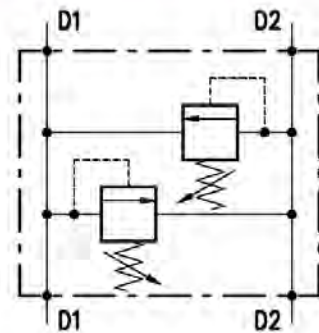

• ASSEMBLY DIAGRAM

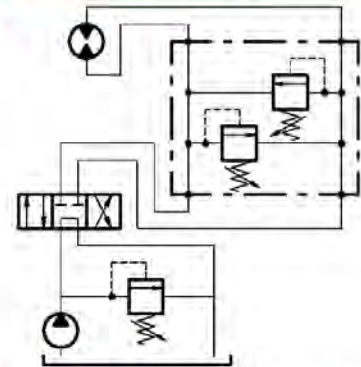

• DESCRIPTION

Dual cross-line relief valve. Direct acting, poppet type, face mounting for Sauer-Danfoss motor OMS series, including O-rings and screws.

• OPERATION

Allows pressure relief on delivery pipes to engines and cylinders.

• PERFORMANCE

Maximum flow: 35 l/min.

Maximum Pressure:

- 210 bar (aluminium valves)

- 350 bar (steel valves)

Application range with standard springs:

- 5 ÷ 40 bar; pressure increase= 1.59 bar/turn (test setting: 30 bar at 5 l/min.)

- 20 ÷ 80 bar; pressure increase= 7.03 bar/turn (test setting: 60 bar at 5 l/min.)

- 50 ÷ 220 bar; pressure increase= 24.15 bar/turn (test setting: 160 bar at 5 l/min.) STANDARD

- 180 ÷ 350 bar; pressure increase= 72.24 bar/turn (test setting: 250 bar at 5 l/min.)

Hysteresis: 85% of the valve setting for 1 L. flow capacity per minute.

To perform setting of the valve see the pressure drop / flow diagram.

Working temperature:

- min. -25°C max. 90°C with standard BUNAN gaskets

- min. -20°C max. 120°C with optional VITON gaskets

Spare Parts KIT:

- Screws and Seals (Ordering code: 5KTM0OMS00)

- External Seals for cartridges type VMP 12 (Ordering code: 5KT1000301)

• CROSS SECTION

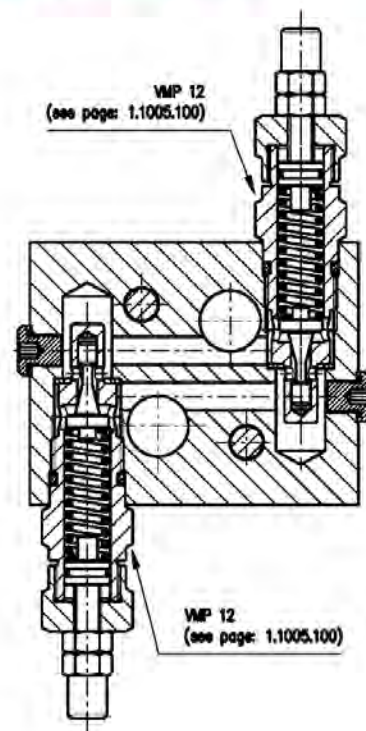

• RECOMMENDATIONS

Fluid: best use mineral oil with viscosity ranging between 10 and 200 cSt.

Filter: see General Informations.

Weight:

- 0.8 kg aluminium valves

- 1.4 kg steel valves

Cartridge used: consult our Technical Department.

Material: internal components made out of high grade steel duly treated and fabricated.

For more information please ask our Technical Department .

Variations and modifications of technical features and dimensions are reserved. HANSA-TMP s.r.l. also reserves the right to stop production of each and any model listed in the catalogue with no notice.

Copyrights on the text contained herein belong to HANSA-TMP s.r.l.. Partial and full reproductions or copies of this catalogue are forbidden.

• RATING DIAGRAMS

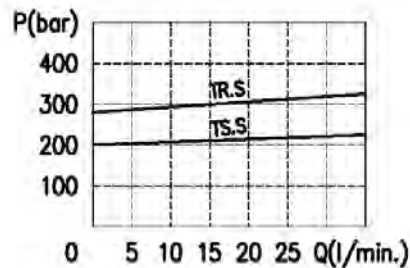
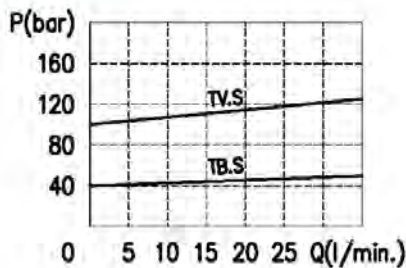

Oil viscosity 46 cSt

• ADJUSTMENTS

S

W

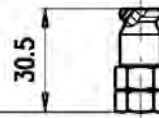
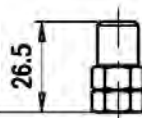

• CODE NUMBER

VAIF 12/D12/ OMS / □□ . □ / □□

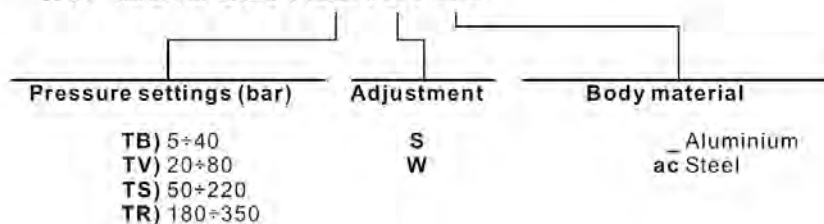

• DIMENSIONS (mm)

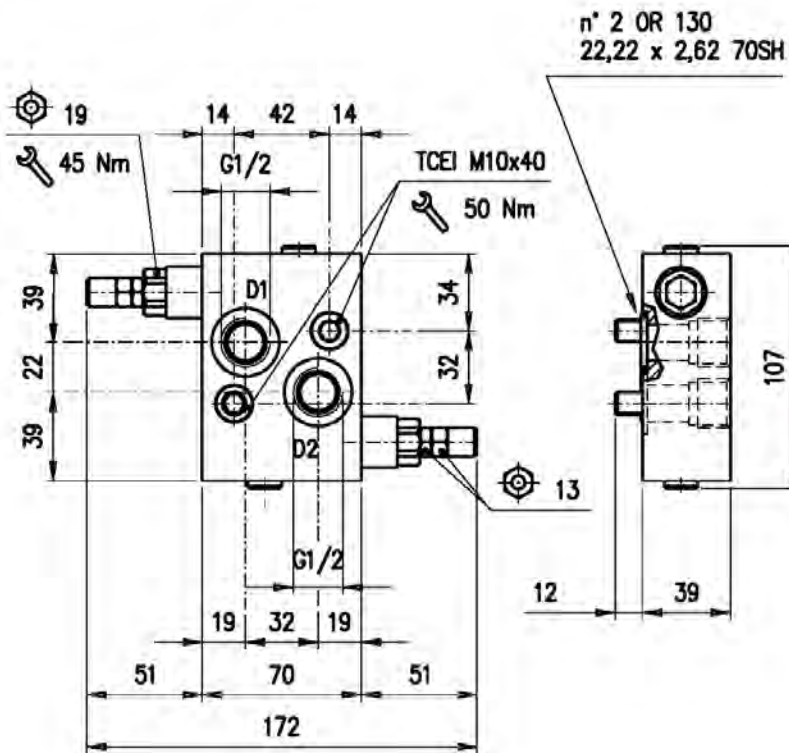

• HYDRAULIC DIAGRAM

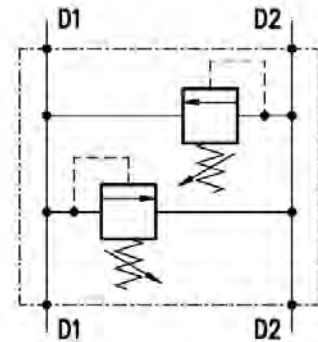

• ASSEMBLY DIAGRAM

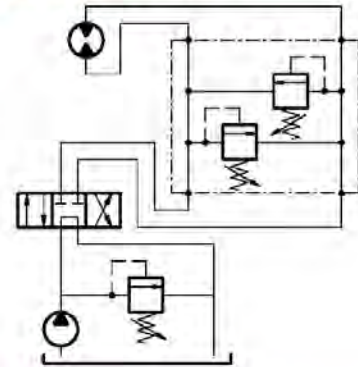

• DESCRIPTION

Dual cross-line relief valve. Direct acting, poppet type, face mounting for Sauer-Danfoss motor OMS series, including O-rings and screws

• OPERATION

Allows pressure relief on delivery pipes to engines and cylinders.

• PERFORMANCE

Maximum flow: 35 l/min.

Maximum Pressure:

- 210 bar (aluminium valves)
- 350 bar (steel valves)

Application range with standard springs:

- 5 ÷ 40 bar; pressure increase= 4.8 bar/turn (test setting: 30 bar at 5 l/min.)
- 20 ÷ 80 bar; pressure increase= 15.6 bar/turn (test setting: 60 bar at 5 l/min.)
- 50 ÷ 220 bar; pressure increase= 52 bar/turn (test setting: 160 bar at 5 l/min.) STANDARD
- 180 ÷ 350 bar; pressure increase= 63 bar/turn (test setting: 280 bar at 5 l/min.)

Hysteresis: 85% of the valve setting for 1 L. flow capacity per minute.

To perform setting of the valve see the pressure drop / flow diagram.

Working temperature:

- Min. -25°C max. 90°C with standard BUNAN gaskets
- min. -20°C max. 120°C with optional VITON gaskets

Spare Parts KIT:

Screws and Seals (Ordering code: 5KTM0OMS00)

• CROSS SECTION

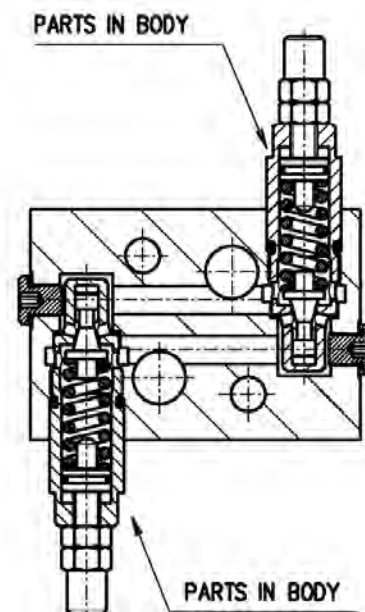

• **RECOMMANDATIONS**

Fluid: best use mineral oil with viscosity ranging between 10 and 200 cSt.

Filter: see General Informations.

Weight:

- 0.7 kg aluminium valves

- 1.2 kg steel valves

Cartridge used: consult our Technical Department.

Material: internal components made out of high grade steel duly treated and fabricated.

For more information please ask our Technical Department .

Variations and modifications of technical features and dimensions are reserved. **HANSA-TMP s.r.l.** also reserves the right to stop production of each and any model listed in the catalogue with no notice.

Copyrights on the text contained herein belong to **HANSA-TMP s.r.l.**. Partial and full reproductions or copies of this catalogue are forbidden.

• **RATING DIAGRAMS**

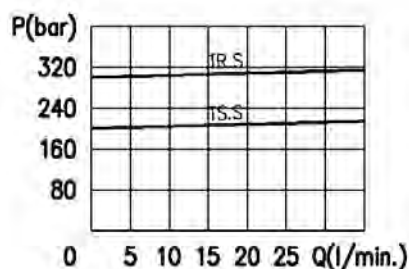
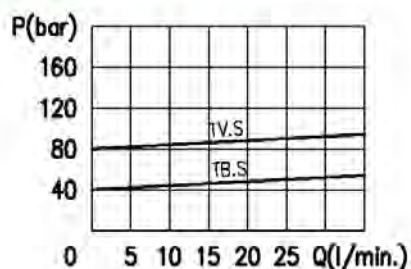

Oil viscosity 46 cSt

• **ADJUSTMENTS**

W

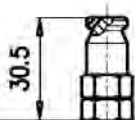

S

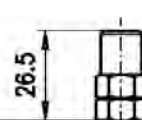

• **CODE NUMBER**

VAIF 5/D12/ OMS / □□ . □ / □□

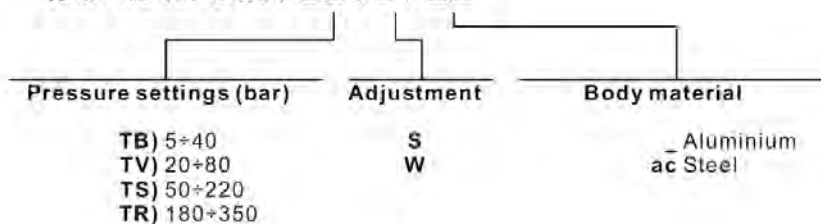

• DIMENSIONS (mm)

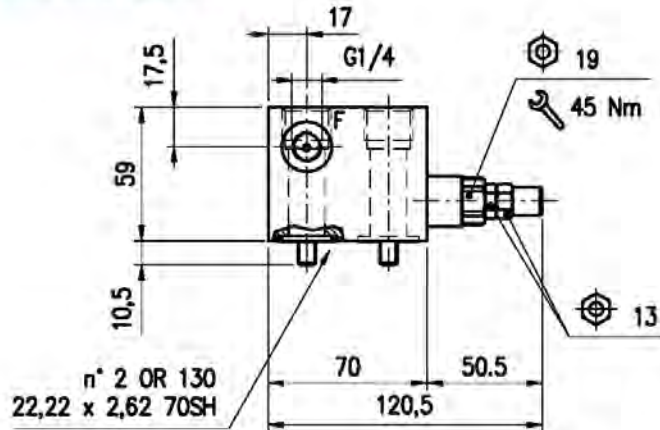

• HYDRAULIC DIAGRAM

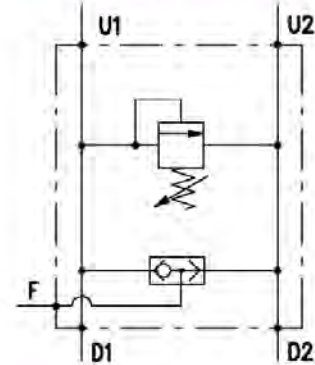

• ASSEMBLY DIAGRAM

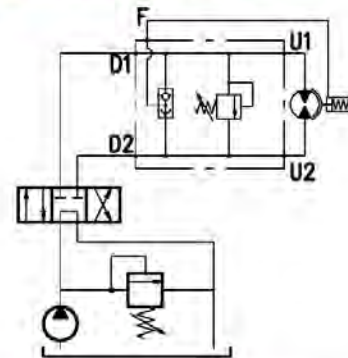

• DESCRIPTION

Single cross-line relief valve. Direct acting, poppet type, with shuttle valve, face mounting for Sauer-Danfoss motor OMP-OMPL-OMR series, including O-rings and screws

• OPERATION

Allows pressure relief on delivery pipes to engines and cylinders.
The special shuttle valve allows releasing of the hydraulic parking brakes.

• PERFORMANCE

Maximum flow: 35 l/min.

Maximum Pressure:

- 210 bar (aluminium valves)
- 350 bar (steel valves)

Application range with standard springs:

- 5 + 80 bar; pressure increase= 9,4 bar/turn (test setting: 60 bar at 5 l/min.)
- 40 + 150 bar; pressure increase= 30,5 bar/turn (test setting: 120 bar at 5 l/min.)
- 140 + 190 bar; pressure increase= 40,4 bar/turn (test setting: 150 bar at 5 l/min.) STANDARD
- 180 + 350 bar; pressure increase= 101 bar/turn (test setting: 260 bar at 5 l/min.)

Hysteresis: 85% of the valve setting for 1 L. flow capacity per minute.

To perform setting of the valve see the pressure drop / flow diagram.

Working temperature:

- min. -25°C max. 90°C with standard BUNAN gaskets
- min. -20°C max. 120°C with optional VITON gaskets

Spare Parts KIT: Screws and Seals (Ordering code: 5KTM00MR02)

• CROSS SECTION

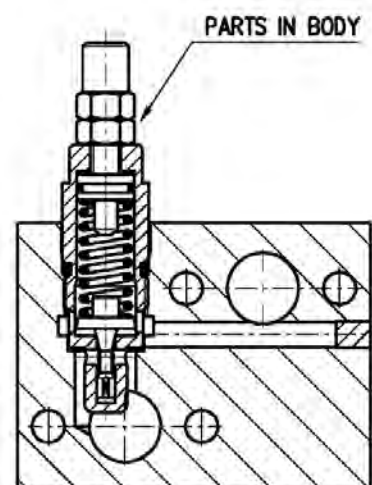

• **RECOMMENDATIONS**

Fluid: best use mineral oil with viscosity ranging between 10 and 200 cSt.

Filter: see General Informations.

Weight:

- 1 kg aluminium valves

- 2,2 kg steel valves

Cartridge used: consult our Technical Department.

Material: internal components made out of high grade steel duly treated and fabricated.

For more information please ask our Technical Department .

Variations and modifications of technical features and dimensions are reserved. **HANSA-TMP s.r.l.** also reserves the right to stop production of each and any model listed in the catalogue with no notice.

Copyrights on the text contained herein belong to **HANSA-TMP s.r.l.**. Partial and full reproductions or copies of this catalogue are forbidden.

• **RATING DIAGRAMS**

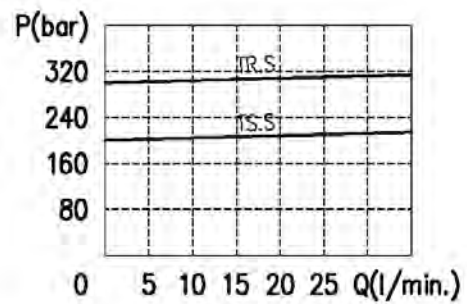
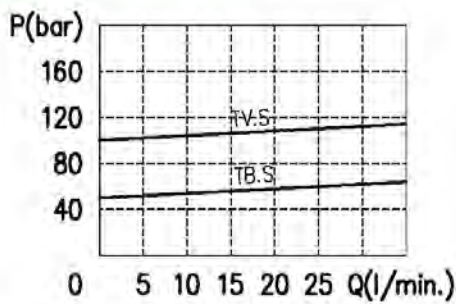

Oil viscosity 46 cSt

• **ADJUSTMENTS**

W

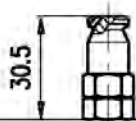

S

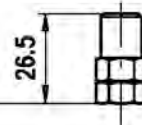

• **CODE NUMBER**

VAIF 5Y/D1S/12/SF/OMR / □□ . □ / □□

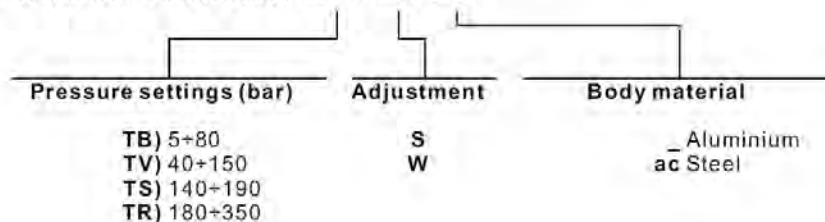

• DIMENSIONS (mm)

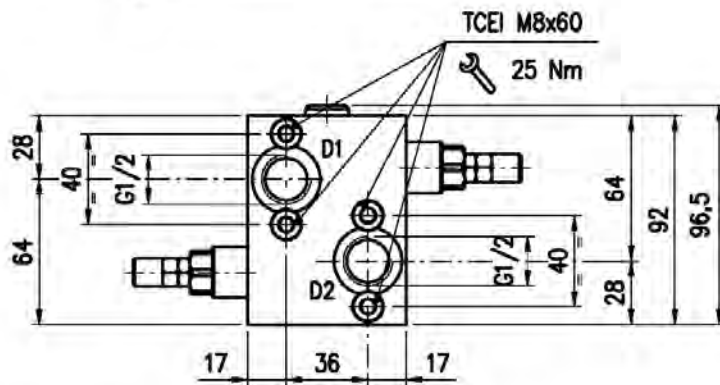
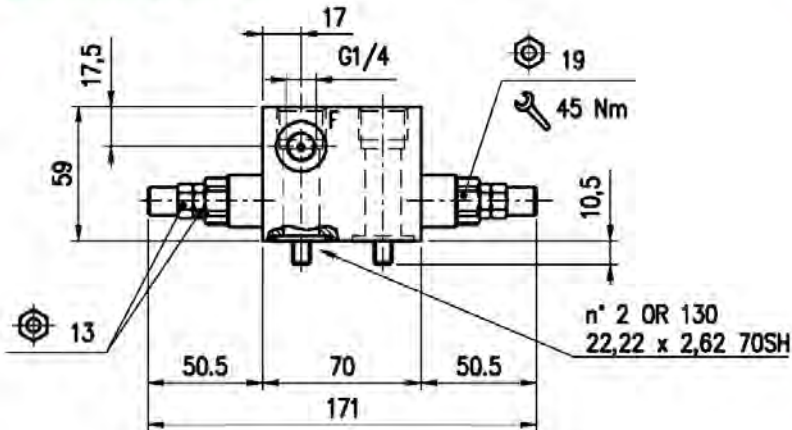

• HYDRAULIC DIAGRAM

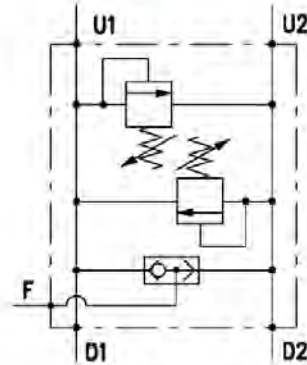

• ASSEMBLY DIAGRAM

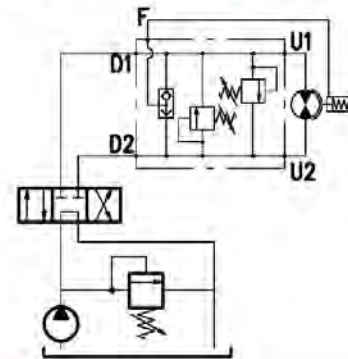

• DESCRIPTION

Dual cross-line relief valve. Direct acting, poppet type, with shuttle valve, face mounting for Sauer-Danfoss motor OMP-OMPL-OMR series, including O-rings and screws.

• OPERATION

Allows pressure relief on delivery pipes to engines and cylinders. The special shuttle valve allows releasing of the hydraulic parking brakes.

• PERFORMANCE

Maximum flow: 35 l/min.

Maximum Pressure:

- 210 bar (aluminium valves)
- 350 bar (steel valves)

Application range with standard springs:

- 5 ÷ 80 bar; pressure increase= 9,4 bar/turn (test setting: 60 bar at 5 l/min.)
- 40 ÷ 150 bar; pressure increase= 30,5 bar/turn (test setting: 120 bar at 5 l/min.)
- 140 ÷ 190 bar; pressure increase= 40,4 bar/turn (test setting: 150 bar at 5 l/min.) STANDARD
- 180 ÷ 350 bar; pressure increase= 101 bar/turn (test setting: 260 bar at 5 l/min.)

Hysteresis: 85% of the valve setting for 1 L. flow capacity per minute.

To perform setting of the valve see the pressure drop / flow diagram.

Working temperature:

- min. -25°C max. 90°C with standard BUNAN gaskets
- min. -20°C max. 120°C with optional VITON gaskets

Spare Parts KIT:

Screws and Seals (Ordering code: 5K1M00MR02)

• CROSS SECTION

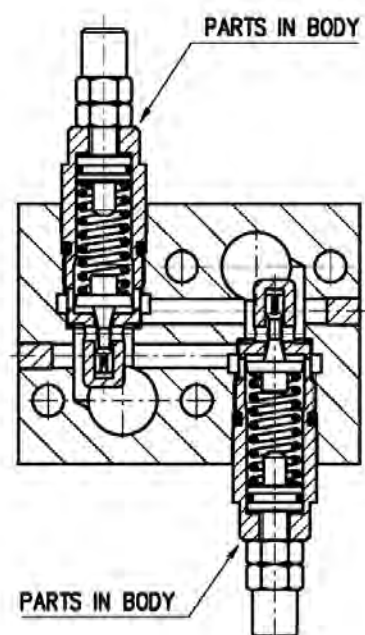

• RECOMMANDATIONS

Fluid: best use mineral oil with viscosity ranging between 10 and 200 cSt.

Filter: see General Informations.

Weight:

- 1,1 kg aluminium valves
- 2,4 kg steel valves

Cartridge used: consult our Technical Department.

Material: internal components made out of high grade steel duly treated and fabricated.

For more information please ask our Technical Department .

Variations and modifications of technical features and dimensions are reserved. HANSA-TMP s.r.l. also reserves the right to stop production of each and any model listed in the catalogue with no notice.

Copyrights on the text contained herein belong to HANSA-TMP s.r.l.. Partial and full reproductions or copies of this catalogue are forbidden.

• RATING DIAGRAMS

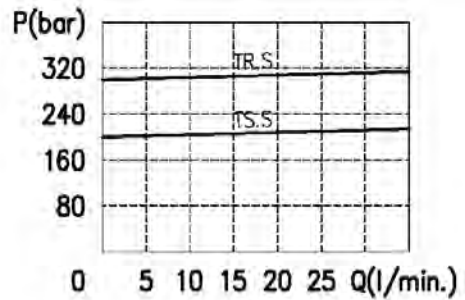
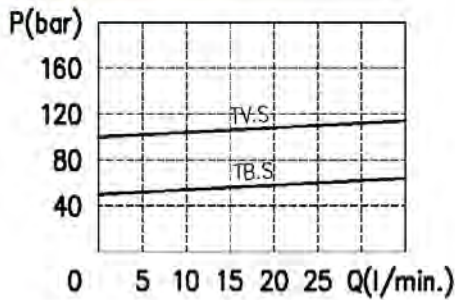

Oil viscosity 46 cSt

• ADJUSTMENTS

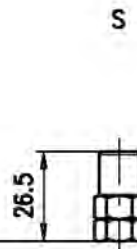
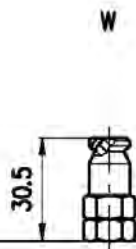

• CODE NUMBER

VAIF 5Y/D1D/12/SF/OMR / □□ . □ / □□

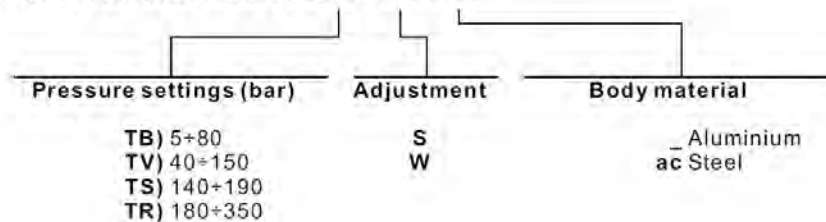

• DIMENSIONS (mm)

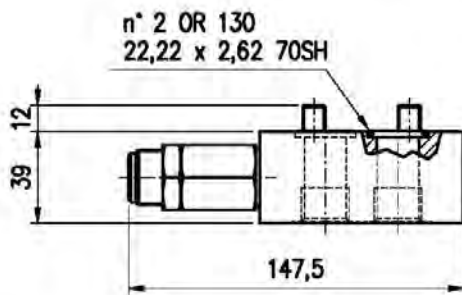
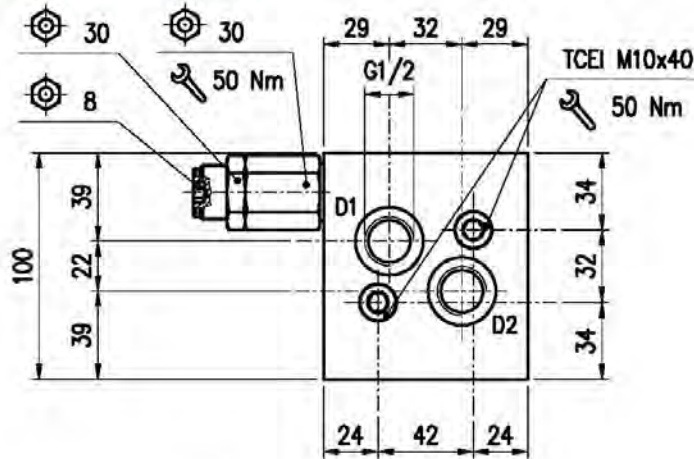

• HYDRAULIC DIAGRAM

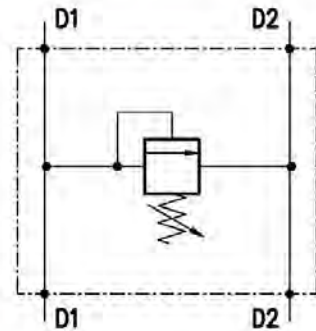

• ASSEMBLY DIAGRAM

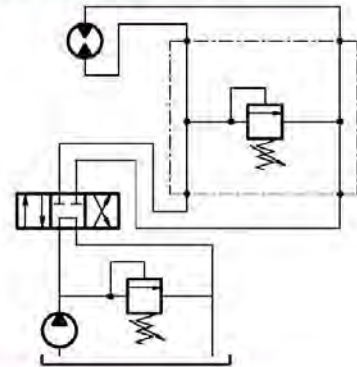

• DESCRIPTION

Single cross-line relief valve. Differential control, conical seat, face mounting for Sauer-Danfoss motor OMS series, including O-Rings and screws.

• OPERATION

Allows pressure relief on delivery pipes to engines and cylinders.

• PERFORMANCE

Maximum flow: 60 l/min.

Maximum Pressure:

- 210 bar aluminium valve
- 350 bar steel valve

Application range with standard springs:

- 5 ÷ 210 bar; pressure increase = 47 bar/turn (test setting: 150 bar at 5 l/min.) STANDARD
- 50 ÷ 350 bar; pressure increase = 99 bar/turn (test setting: 250 bar at 5 l/min.)

To perform setting of the valve see the pressure drop / flow diagram.

Hysteresis: 85% of the valve setting for 1 L. flow capacity per minute.

Oil leak between P and T: disregardable.

Working temperature:

- min. -25°C max. 90°C with standard BUNAN gaskets
- min. -20°C max. 120°C with optional VITON gaskets

Spare parts KIT:

- A) Screws and Seals (Ordering code: 5KTM0OMS00)
- B) External Seals for cartridges type VMPD 12 (Ordering code: 5KT1200300)

• CROSS SECTION

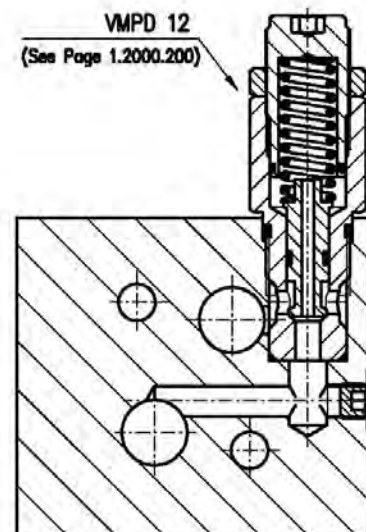

• DIMENSIONS (mm)

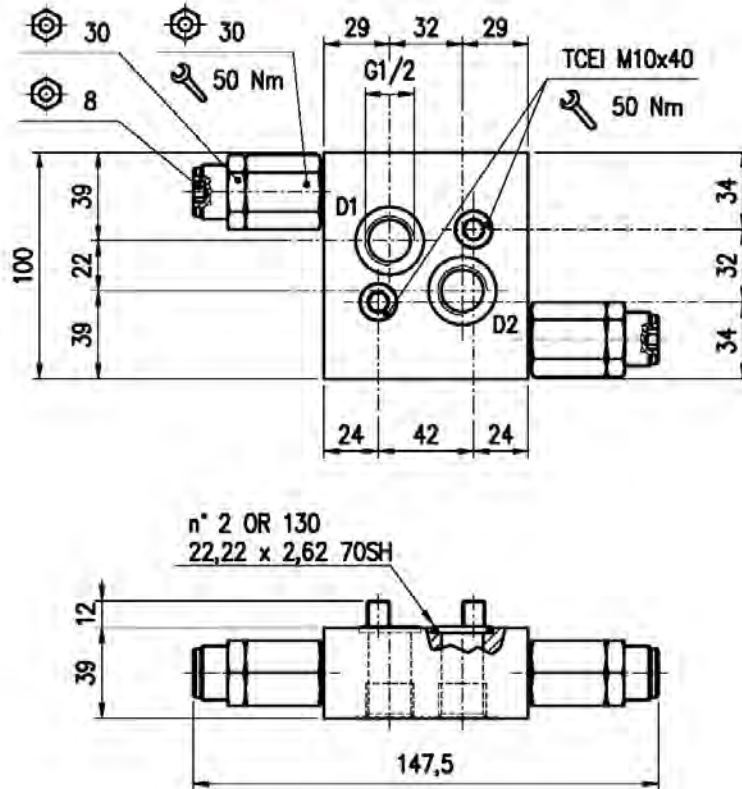

• HYDRAULIC DIAGRAM

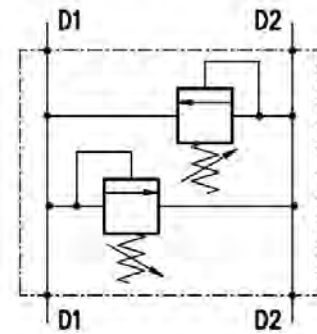

• ASSEMBLY DIAGRAM

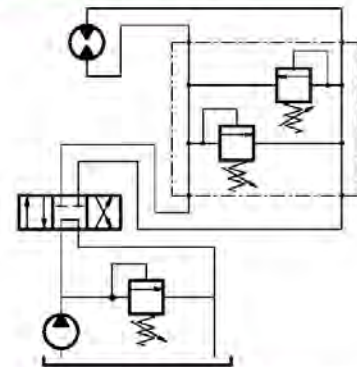

• DESCRIPTION

Dual cross-line relief valve. Differential control, conical seat, face mounting for Sauer-Danfoss motor OMS series, including O-Rings and screws.

• OPERATION

Allows pressure relief on delivery pipes to engines and cylinders.

• PERFORMANCE

Maximum flow: 60 l/min.

Maximum Pressure:

- 210 bar aluminium valve
- 350 bar steel valve

Application range with standard springs:

- 5 ÷ 210 bar; pressure increase = 47 bar/turn (test setting: 150 bar at 5 l/min.) STANDARD
- 50 ÷ 350 bar; pressure increase = 99 bar/turn (test setting: 250 bar at 5 l/min.)

To perform setting of the valve see the pressure drop / flow diagram.

Hysteresis: 85% of the valve setting for 1 L. flow capacity per minute

Oil leak between P and T: disregarable.

Working temperature:

- min. -25°C max. 90°C with standard BUNAN gaskets
- min. -20°C max. 120°C with optional VITON gaskets

Spare parts KIT:

A) Screws and Seals (Ordering code: 5KTM0OMS00)

B) External Seals for cartridges type VMPD 12 (Ordering code: 5KT1200300)

• CROSS SECTION

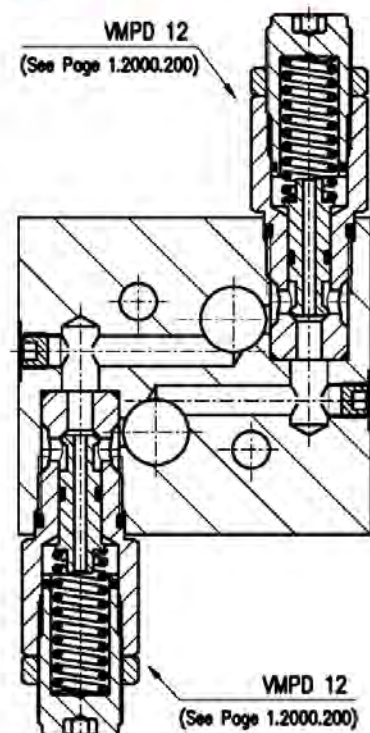

• RECOMMANDATIONS

Fluid: best use mineral oil with viscosity ranging between 10 and 200 cSt.

Filter: see General Informations.

Weight:

- aluminium valves 1.14 kg

- steel valves 2.00 kg

Cartridge used: consult our Technical Department.

Material: made out of high grade steel duly treated and fabricated.

For more information please ask our Technical Department.

Variations and modifications of technical features and dimensions are reserved. **HANSA-TMP s.r.l.** also reserves the right to stop production of each and any model listed in the catalogue with no notice.

Copyrights on the text contained herein belong to **HANSA-TMP s.r.l.** . Partial and full reproductions or copies of this catalogue are forbidden.

• RATING DIAGRAMS

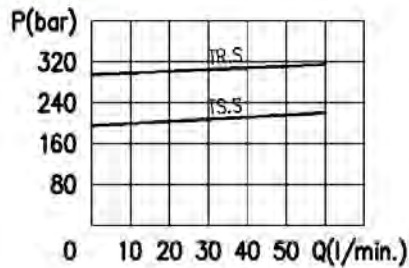

Oil viscosity 46 cSt

• CODE NUMBER

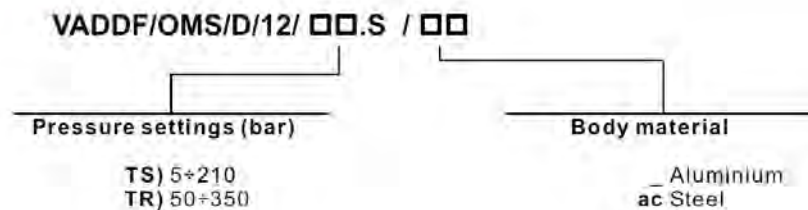

• DIMENSIONS (mm)

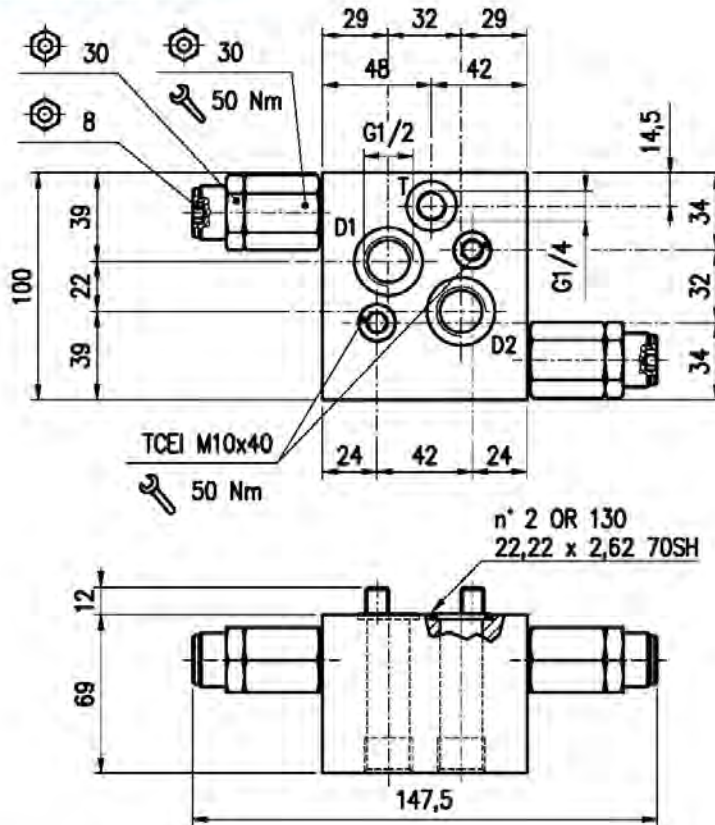

• HYDRAULIC DIAGRAM

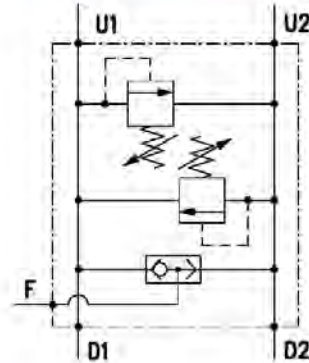

• ASSEMBLY DIAGRAM

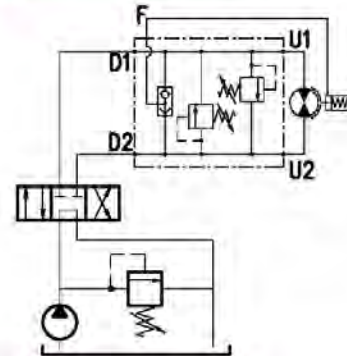

• DESCRIPTION

Dual cross-line relief valve. Differential control, conical seat, with shuttle valve, face mounting for Sauer-Danfoss motor OMS series, including O-Rings and screws.

• OPERATION

Allows pressure relief on delivery pipes to engines and cylinders. The special shuttle valve allows releasing of the hydraulic parking brakes.

• PERFORMANCE

Maximum flow: 60 l/min.

Maximum Pressure:

- 210 bar aluminium valve
- 350 bar steel valve

Application range with standard springs:

- 5 ÷ 210 bar; pressure increase = 47 bar/turn (test setting: 150 bar at 5 l/min.) STANDARD
- 50 ÷ 350 bar; pressure increase = 99 bar/turn (test setting: 250 bar at 5 l/min.)

To perform setting of the valve see the pressure drop / flow diagram.

Hysteresis: 85% of the valve setting for 1 L. flow capacity per minute.

Oil leak between P and T: disregarable.

Working temperature:

- min. -25°C max. 90°C with standard BUNAN gaskets
- min. -20°C max. 120°C with optional VITON gaskets

Spare parts KIT:

A) Screws and Seals (Ordering code: 5KTM0OMS01)

B) External Seals for cartridges type VMPD 12 (Ordering code: 5KT1200300)

• CROSS SECTION

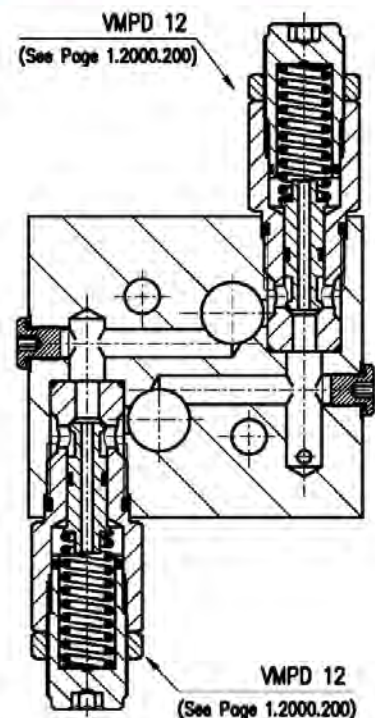

• **RECOMMANDATIONS**

Fluid: best use mineral oil with viscosity ranging between 10 and 200 cSt.

Filter: see General Informations.

Weight:

- aluminium valves 2.5 kg

- steel valves 4.85 kg

Cartridge used: consult our Technical Department.

Material: made out of high grade steel duly treated and fabricated.

For more information please ask our Technical Department .

Variations and modifications of technical features and dimensions are reserved. **HANSA-TMP s.r.l.** also reserves the right to stop production of each and any model listed in the catalogue with no notice.

Copyrights on the text contained herein belong to **HANSA-TMP s.r.l.**. Partial and full reproductions or copies of this catalogue are forbidden.

• **RATING DIAGRAMS**

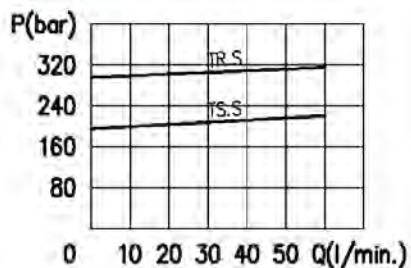

Oil viscosity 46 cSt

• **CODE NUMBER**

VADDF/OMS/D/SF/12/ □□.S / □□

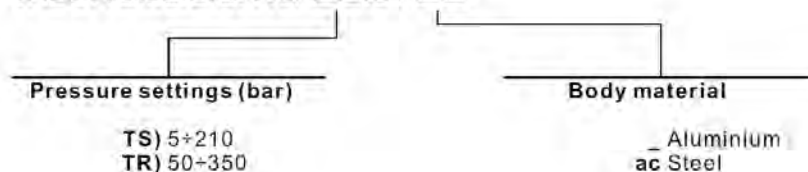

• DIMENSIONS (mm)

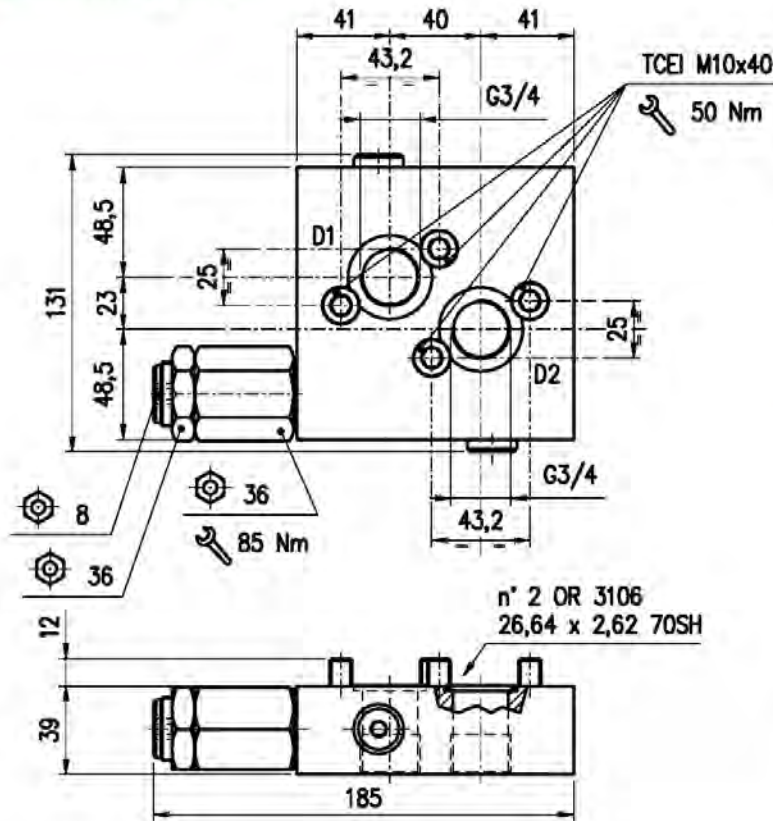

• HYDRAULIC DIAGRAM

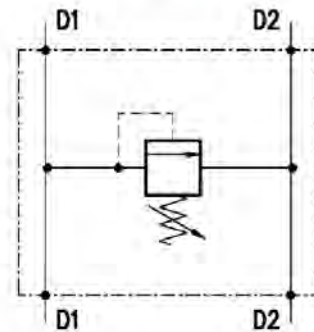

• ASSEMBLY DIAGRAM

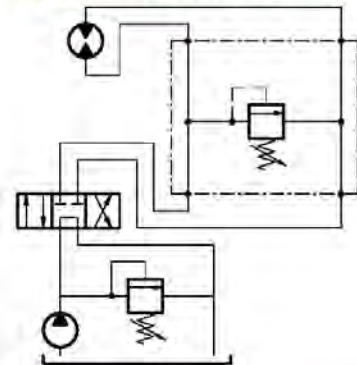

• DESCRIPTION

Single cross-line relief valve. Differential control, conical seat, face mounting for Sauer-Danfoss motor OMT series, including O-Rings and screws.

• OPERATION

Allows pressure relief on delivery pipes to engines and cylinders.

• PERFORMANCE

Maximum flow: 100 l/min.

Maximum Pressure:

- 210 bar aluminium valve
- 350 bar steel valve

Application range with standard springs:

- 5 ÷ 210 bar, pressure increase = 37 bar/turn (test setting: 150 bar at 5 l/min.) STANDARD
- 50 ÷ 350 bar, pressure increase = 63 bar/turn (test setting: 250 bar at 5 l/min.)

To perform setting of the valve see the pressure drop / flow diagram.

Hysteresis: 85% of the valve setting for 1 L. flow capacity per minute.

Oil leak between P and T : disregarable.

Working temperature:

- min. -25°C max. 90°C with standard BUNA N gaskets
- min. -20°C max. 120°C with optional VITON gaskets

Spare parts KIT:

- A) Screws and Seals (Ordering code: 5KTM00MT01)
- B) External Seals for cartridges type VMPD 34 (Ordering code: 5KT1200400)

• CROSS SECTION

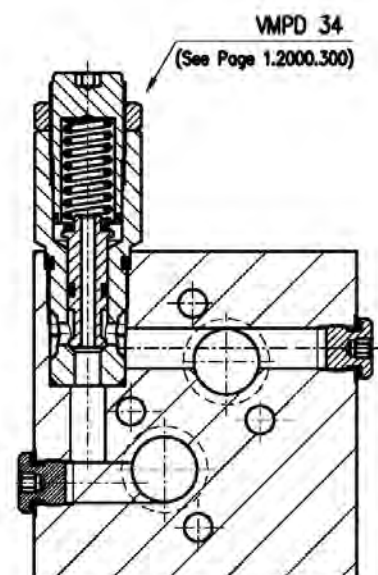

RECOMMENDATIONS

Fluid: best use mineral oil with viscosity ranging between 10 and 200 cSt.

Filter: see General Informations.

Weight:

- aluminium valves 2.2 kg

- steel valves 5.8 kg

Cartridge used: consult our Technical Department.

Material: made out of high grade steel duly treated and fabricated.

For more information please ask our Technical Department .

Variations and modifications of technical features and dimensions are reserved. **HANSA-TMP s.r.l.** also reserves the right to stop production of each and any model listed in the catalogue with no notice.

Copyrights on the text contained herein belong to **HANSA-TMP s.r.l.**. Partial and full reproductions or copies of this catalogue are forbidden.

• RATING DIAGRAMS

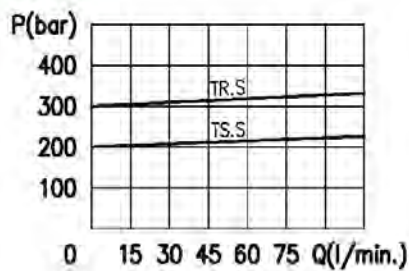

Oil viscosity 46 cSt

• CODE NUMBER

VADDF/ OMT/S 34 / □□ .S / □□

Pressure settings (bar)

TS) 5+210
TR) 50+350

Body material

Aluminium
ac Steel

• RECOMMANDATIONS

Fluid: best use mineral oil with viscosity ranging between 10 and 200 cSt.

Filter: see General Informations.

Weight:

- aluminium valves 2.8 kg

- steel valves 6.3 kg

Cartridge used: consult our Technical Department.

Material: made out of high grade steel duly treated and fabricated.

For more information please ask our Technical Department .

Variations and modifications of technical features and dimensions are reserved. HANSA-TMP s.r.l. also reserves the right to stop production of each and any model listed in the catalogue with no notice.

Copyrights on the text contained herein belong to HANSA-TMP s.r.l.. Partial and full reproductions or copies of this catalogue are forbidden.

• RATING DIAGRAMS

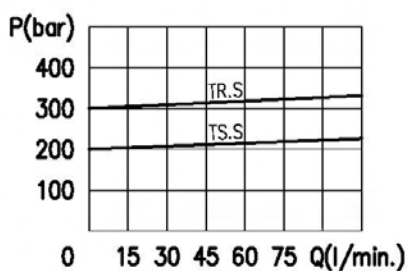

Oil viscosity 46 cSt

• CODE NUMBER

VADDF/OMT /D/ 34 / □□.S / □□

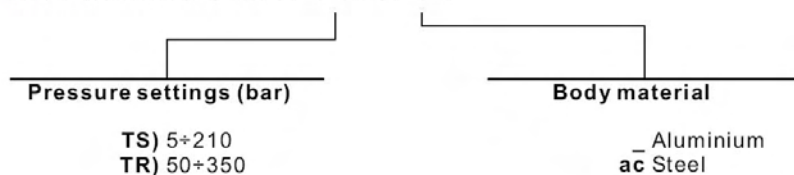

• DIMENSIONS (mm)

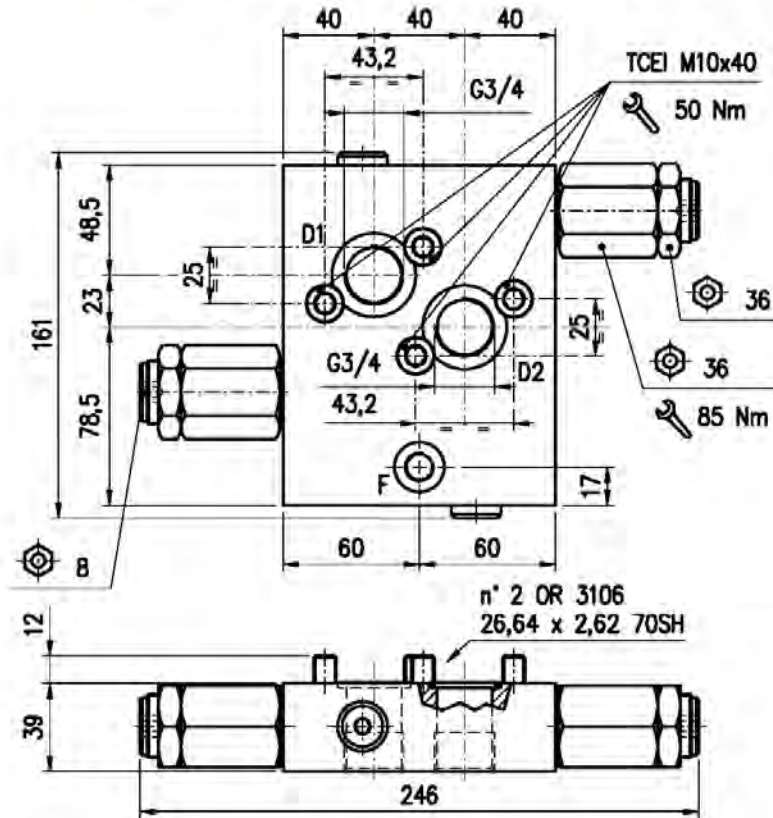

• HYDRAULIC DIAGRAM

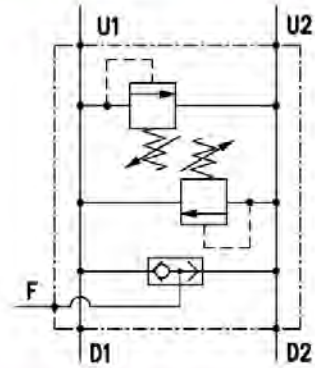

• ASSEMBLY DIAGRAM

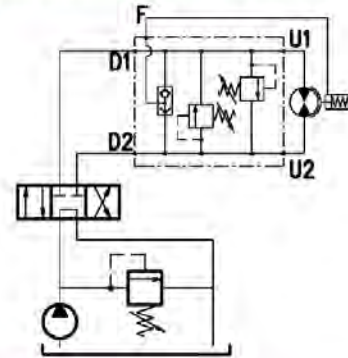

• DESCRIPTION

Dual cross-line relief valve. Differential control, conical seat, with shuttle valve, face mounting for Sauer-Danfoss motor OMT series, including O-Rings and screws.

• OPERATION

Allows pressure relief on delivery pipes to engines and cylinders. The special shuttle valve allows releasing of the hydraulic parking brakes.

• PERFORMANCE

Maximum flow: 100 l/min.

Maximum Pressure:

- 210 bar aluminium valve
- 350 bar steel valve

Application range with standard springs:

- 5 ÷ 210 bar, pressure increase = 37 bar/turn (test setting: 150 bar at 5 l/min.) STANDARD
- 50 ÷ 350 bar, pressure increase = 63 bar/turn (test setting: 250 bar at 5 l/min.)

To perform setting of the valve see the pressure drop / flow diagram.

Hysteresis: 85% of the valve setting for 1 L. flow capacity per minute.

Oil leak between P and T: disregarable.

Working temperature:

- min. -25°C max. 90°C with standard BUNAN gaskets
- min. -20°C max. 120°C with optional VITON gaskets

Spare parts KIT:

- A) Screws and Seals (Ordering code: 5KTM00MT01)
- B) External Seals for cartridges type VMPD 34 (Ordering code: 5KT1200400)

• CROSS SECTION

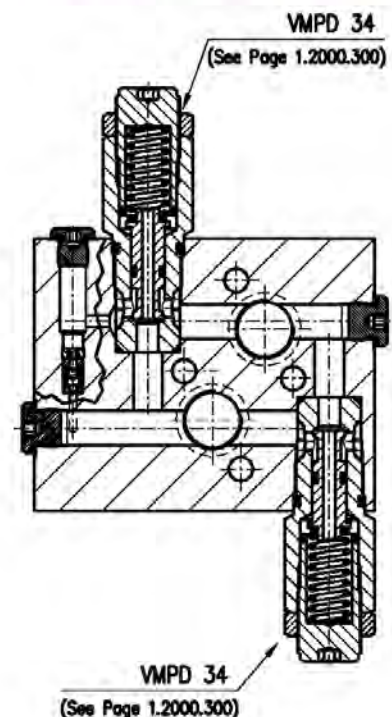

RECOMMENDATIONS

Fluid: best use mineral oil with viscosity ranging between 10 and 200 cSt.

Filter: see General Informations.

Weight:

- aluminium valves 3.2 kg
- steel valves 7.2 kg

Cartridge used: consult our Technical Department.

Material: made out of high grade steel duly treated and fabricated.

For more information please ask our Technical Department.

Variations and modifications of technical features and dimensions are reserved. HANSA-TMP s.r.l. also reserves the right to stop production of each and any model listed in the catalogue with no notice.

Copyrights on the text contained herein belong to HANSA-TMP s.r.l.. Partial and full reproductions or copies of this catalogue are forbidden.

• **RATING DIAGRAMS**

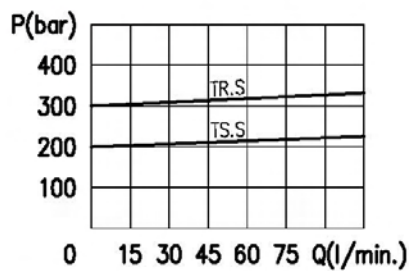

Oil viscosity 46 cSt

• **CODE NUMBER**

VADDF/OMT/D/SF 34 / □□.S / □□

Pressure settings (bar)

TS) 5+210
 TR) 50+350

Body material

_ Aluminium
 ac Steel

• DIMENSIONS (mm)

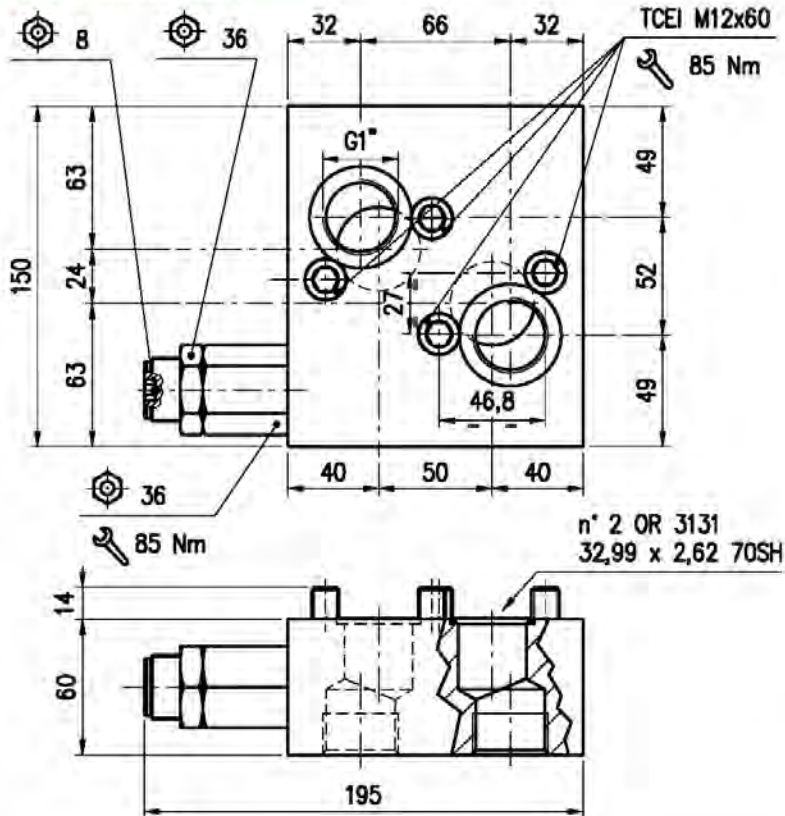

• HYDRAULIC DIAGRAM

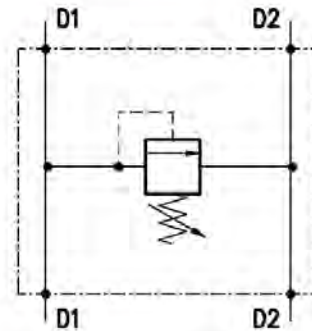

• ASSEMBLY DIAGRAM

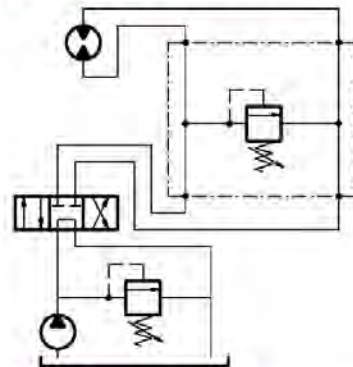

• DESCRIPTION

Single cross-line relief valve. Differential control, conical seat, face mounting for Sauer-Danfoss motor OMV series, including O-Rings and screws.

• OPERATION

Allows pressure relief on delivery pipes to engines and cylinders.

• PERFORMANCE

Maximum flow: 180 l/min.

Maximum Pressure:

- 210 bar aluminium valve
- 350 bar steel valve

Application range with standard springs:

- 5 + 210 bar, pressure increase = 46 bar/turn (test setting: 150 bar at 5 l/min.) STANDARD
- 50 + 350 bar, pressure increase = 96 bar/turn (test setting: 250 bar at 5 l/min.)

To perform setting of the valve see the pressure drop / flow diagram.

Hysteresis: 85% of the valve setting for 1 L. flow capacity per minute.

Oil leak between P and T: disregarable.

Working temperature:

- min. -25°C max. 90°C with standard BUNAN gaskets
- min. -20°C max. 120°C with optional VITON gaskets

Spare parts KIT:

- A) Screws and Seals (Ordering code: 5KTM00MV00)
- B) External Seals for cartridges type VMPD 100 (Ordering code: 5KT1200502)

• CROSS SECTION

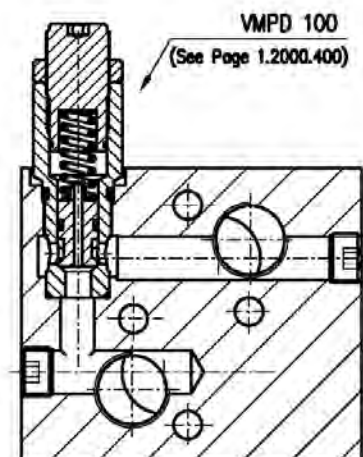

• **RECOMMANDATIONS**

Fluid: best use mineral oil with viscosity ranging between 10 and 200 cSt.

Filter: see General Informations.

Weight:

- aluminium valves 3.3 kg

- steel valves 7.1 kg

Cartridge used: consult our Technical Department.

Material: made out of high grade steel duly treated and fabricated.

For more information please ask our Technical Department.

Variations and modifications of technical features and dimensions are reserved. **HANSA-TMP s.r.l.** also reserves the right to stop production of each and any model listed in the catalogue with no notice.

Copyrights on the text contained herein belong to **HANSA-TMP s.r.l.**. Partial and full reproductions or copies of this catalogue are forbidden.

• **RATING DIAGRAMS**

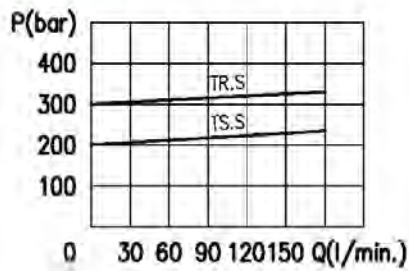

Oil viscosity 46 cSt

• **CODE NUMBER**

VADDF/ OMV/S 100 / □□ .S / □□

Pressure settings (bar)

TS) 5+210
TR) 50+350

Body material

Aluminium
ac Steel

• DIMENSIONS (mm)

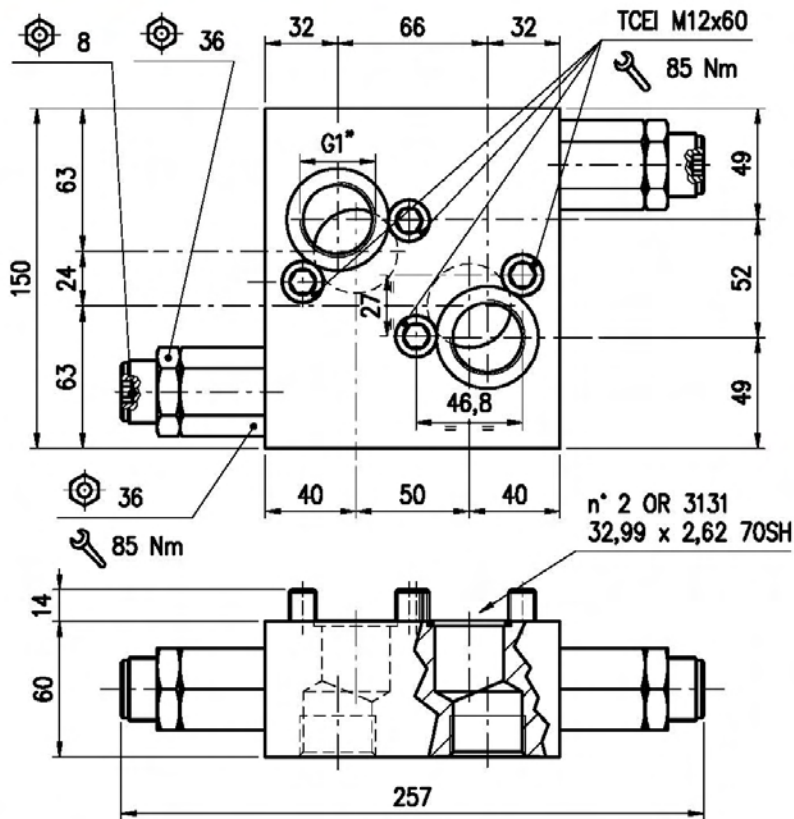

• HYDRAULIC DIAGRAM

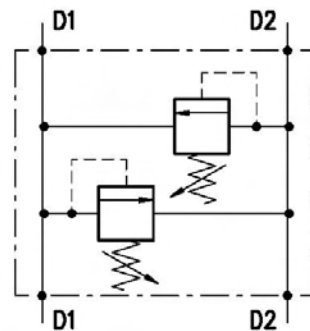

• ASSEMBLY DIAGRAM

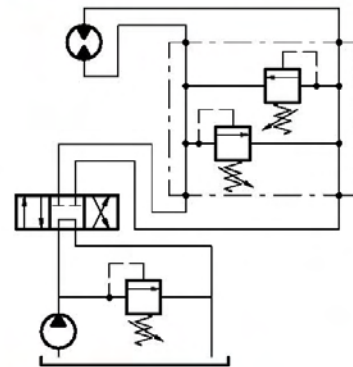

• DESCRIPTION

Dual cross-line relief valve. Differential control, conical seat, face mounting for Sauer-Danfoss motor OMV series, including O-Rings and screws.

• OPERATION

Allows pressure relief on delivery pipes to engines and cylinders.

• PERFORMANCE

Maximum flow: 180 l/min.

Maximum Pressure:

- 210 bar aluminium valve
- 350 bar steel valve

Application range with standard springs:

- 5 + 210 bar, pressure increase = 46 bar/turn (test setting: 150 bar at 5 l/min.) STANDARD
- 50 + 350 bar, pressure increase = 96 bar/turn (test setting: 250 bar at 5 l/min.)

To perform setting of the valve see the pressure drop / flow diagram.

Hysteresis: 85% of the valve setting for 1 L. flow capacity per minute.

Oil leak between P and T: disregardable.

Working temperature:

- min. -25°C max. 90°C with standard BUNAN gaskets
- min. -20°C max. 120°C with optional VITON gaskets

Spare parts KIT:

- A) Screws and Seals (Ordering code: 5KTM00MV00)
- B) External Seals for cartridges type VMPD 100 (Ordering code: 5KT1200502)

• CROSS SECTION

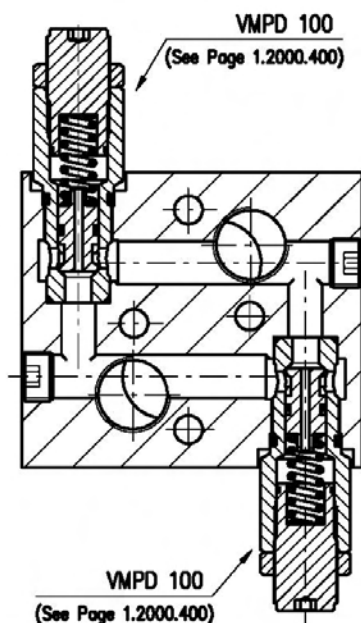

RECOMMENDATIONS

Fluid: best use mineral oil with viscosity ranging between 10 and 200 cSt.

Filter: see General Informations.

Weight:

- aluminium valves 3.9kg

- steel valves 7.7 kg

Cartridge used: consult our Technical Department.

Material: made out of high grade steel duly treated and fabricated.

For more information please ask our Technical Department.

Variations and modifications of technical features and dimensions are reserved. HANSA-TMP s.r.l. also reserves the right to stop production of each and any model listed in the catalogue with no notice.

Copyrights on the text contained herein belong to HANSA-TMP s.r.l.. Partial and full reproductions or copies of this catalogue are forbidden.

• RATING DIAGRAMS

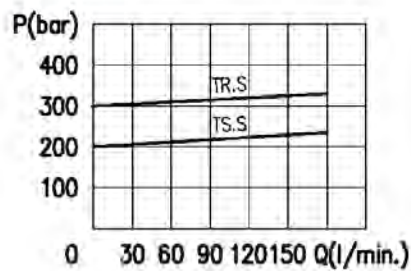

Oil viscosity 46 cSt

• CODE NUMBER

VADDF/ OMV/D 100 / □□ .S / □□

Pressure settings (bar)

TS) 5÷210
TR) 50÷350

Body material

_ Aluminium
ac Steel

• DIMENSIONS (mm)

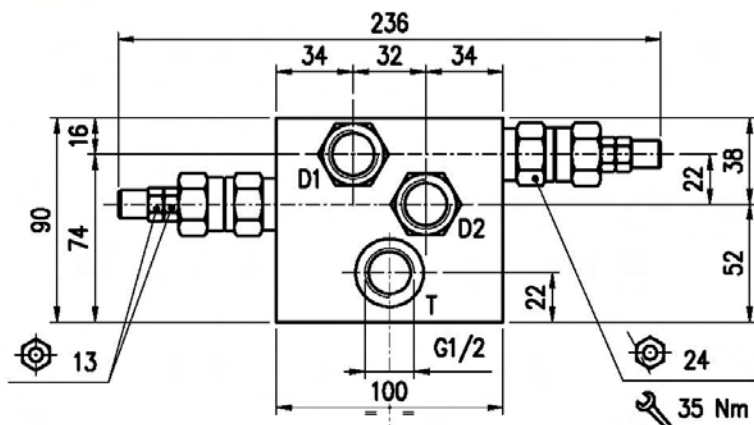

n° 4 WASHER 26x21,5x1,5
Cod. 4RD1211500

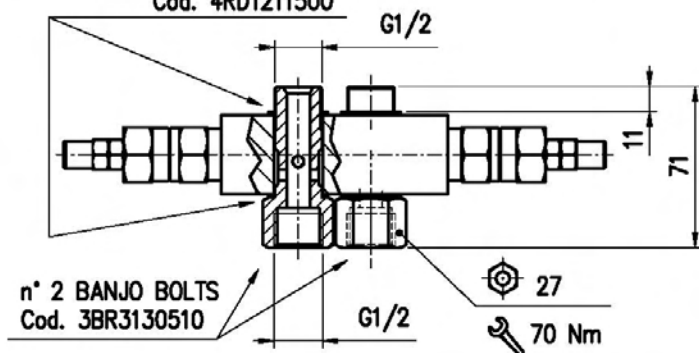

n° 2 BANJO BOLTS
Cod. 3BR3130510

• HYDRAULIC DIAGRAM

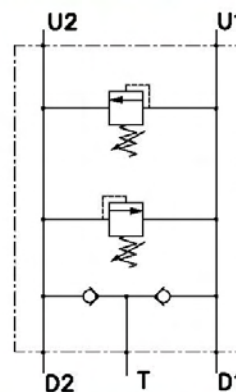

• ASSEMBLY DIAGRAM

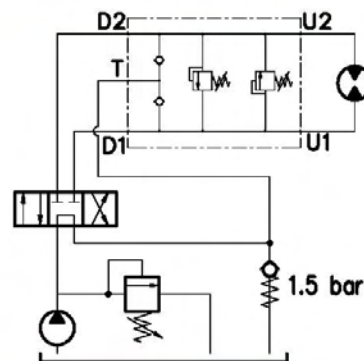

• DESCRIPTION

Dual cross-line relief valve with anti cavitation. Direct acting, poppet type, face mounting for Sauer-Danfoss motor OMS series, including washers and banjo bolts

• OPERATION

Allows pressure relief on delivery pipes to engines and cylinders. When the actuator is braking, two check valves allow for anti cavitation on delivery side.

• PERFORMANCE

Maximum flow: 35 l/min.

Maximum Pressure:

- 210 bar (aluminium valves)
- 350 bar (steel valves)

Application range with standard springs:

- 5 ÷ 40 bar; pressure increase= 1.59 bar/turn (test setting: 30 bar at 5 l/min.)
- 20 ÷ 80 bar; pressure increase= 7.03 bar/turn (test setting: 60 bar at 5 l/min.)
- 50 ÷ 220 bar; pressure increase= 24.15 bar/turn (test setting: 160 bar at 5 l/min.) STANDARD
- 180 ÷ 350 bar; pressure increase= 72.24 bar/turn (test setting: 250 bar at 5 l/min.)

Hysteresis: 85% of the valve setting for 1 L. flow capacity per minute.

To perform setting of the valve see the pressure drop / flow diagram.

Working temperature:

- min. -25°C max. 90°C with standard BUNAN gaskets
- min. -20°C max. 120°C with optional VITON gaskets

Spare Parts KIT:

- Banjo bolts (Ordering code: 3BR3130510)
- External Seals for cartridges type VMP 12 (Ordering code: 5KT1000301)

• CROSS SECTION

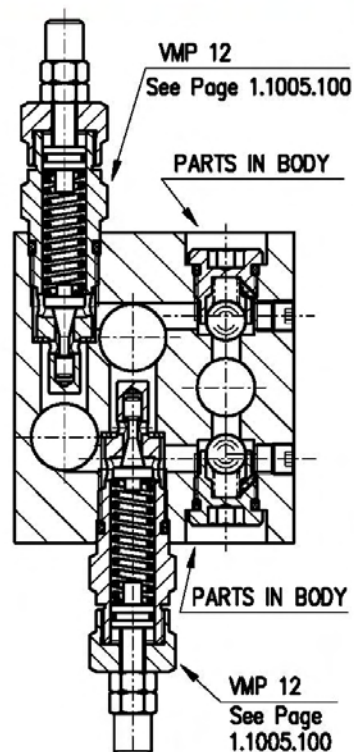

RECOMMENDATIONS

Fluid: best use mineral oil with viscosity ranging between 10 and 200 cSt.

Filter: see General Informations.

Weight:

- 2.5 kg aluminium valves

- 3.3 kg steel valves

Cartridge used: consult our Technical Department.

Material: internal components made out of high grade steel duly treated and fabricated.

For more information please ask our Technical Department.

Variations and modifications of technical features and dimensions are reserved. HANSA-TMP s.r.l. also reserves the right to stop production of each and any model listed in the catalogue with no notice.

Copyrights on the text contained herein belong to HANSA-TMP s.r.l. . Partial and full reproductions or copies of this catalogue are forbidden.

• RATING DIAGRAMS

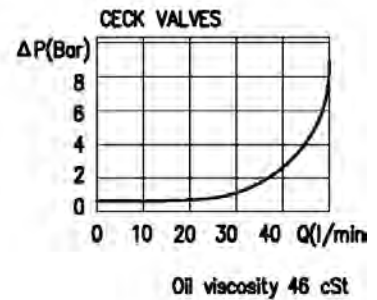
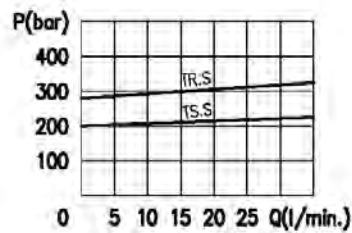
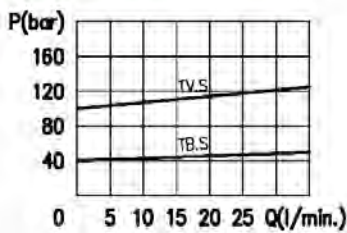

• ADJUSTMENTS

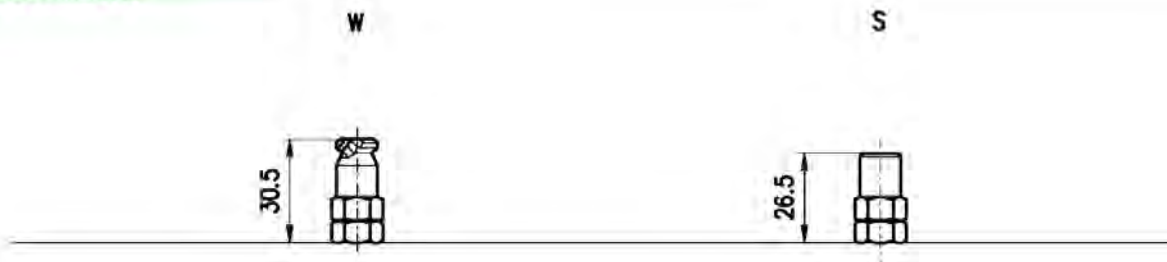

• CODE NUMBER

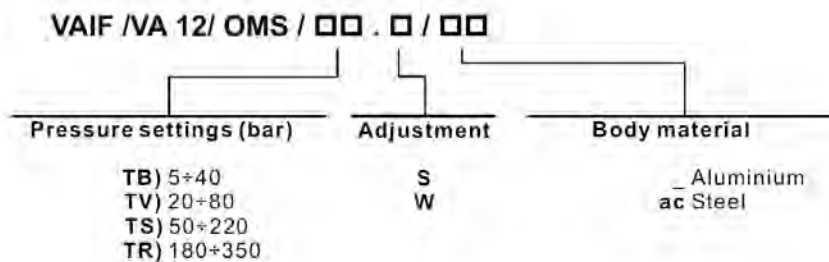

ANTISHOCK VALVES INDEX

Description	type	code	page
Antishock valve with anti-cavitation	VAA / RU / DF 12 / OMR	A.1150.200	54
Antishock valve with anti-cavitation	VAA / RU / DF 12 / OMS	A.1150.300	56
Antishock valve with anti-cavitation	VAA / RU / DF 34 / OMT	A.1150.400	58
Antishock valve with anti-cavitation	VAA / RU / DF 100 / OMV	A.1150.500	60

• DIMENSIONS (mm)

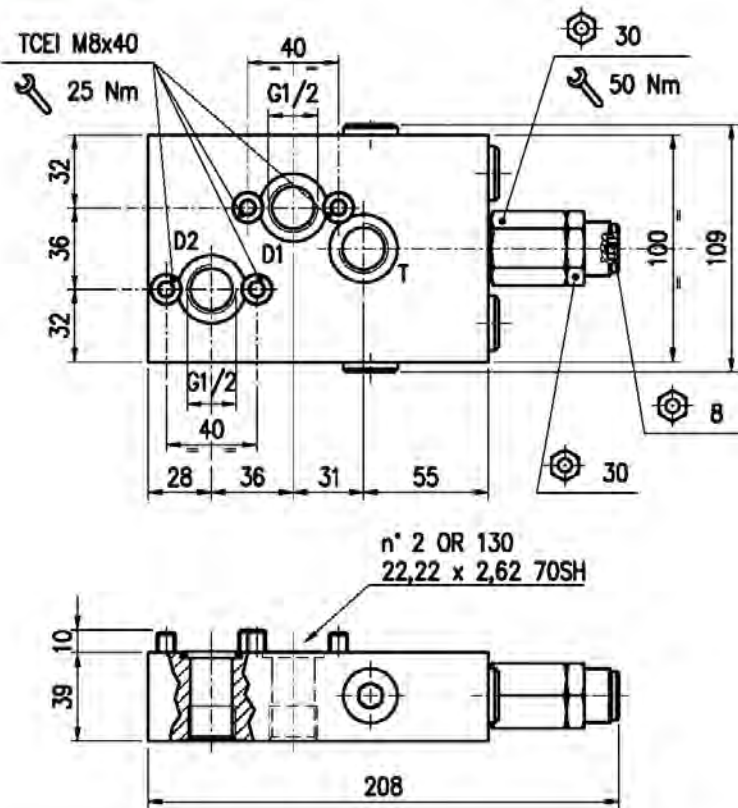

• HYDRAULIC DIAGRAM

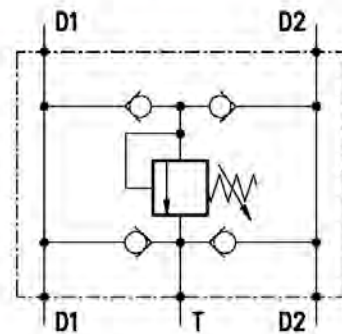

• ASSEMBLY DIAGRAM

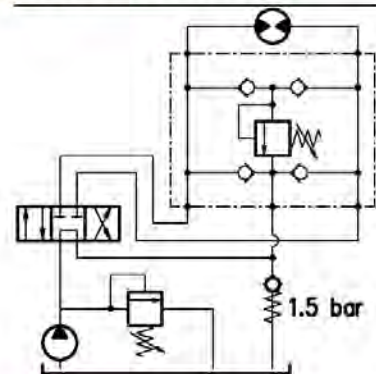

• DESCRIPTION

Antishock valve with anti cavitation and single pressure adjustment. Differential control, conical seat, face mounting for Sauer Danfoss motor OMR series, including O-Rings and screws.

• OPERATION

Allows pressure relief on delivery pipes to engines and cylinders. When the actuator is braking, two check valves allow for anti cavitation on delivery side.

• PERFORMANCE

Maximum flow: 60 l/min.

Maximum Pressure:

- 210 bar (aluminium valve)
- 350 bar (steel valve)

Application range with standard springs:

- 5 - 210 bar, pressure increase = 47 bar/turn (test setting: 150 bar at 5 l/min.) STANDARD
- 50 - 350 bar, pressure increase = 99 bar/turn (test setting: 250 bar at 5 l/min.)

To perform setting of the valve see the pressure drop / flow diagram.

Hysteresis: 85% of the valve setting for 1 L. flow capacity per minute.

Oil leak between P and T: disregarable.

Working temperature:

- min. -25°C max. 90°C with standard BUNAN gaskets
- min. -20°C max. 120°C with optional VITON gaskets

Spare parts KIT:

A) Screws and Seals (Ordering code: 5KTM00MR01)

B) External Seals for cartridges type VMPD 12 (Ordering code: 5KT1200300)

• CROSS SECTION

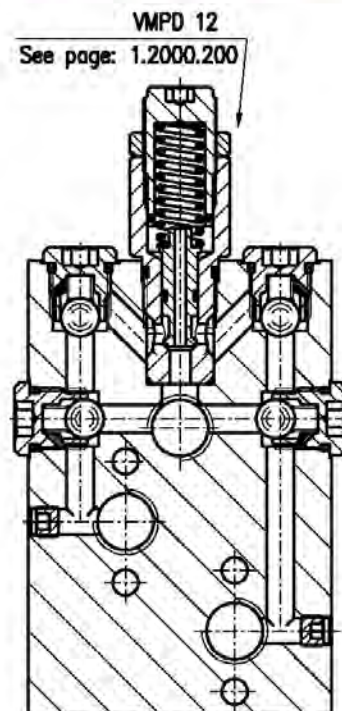

• RECOMMANDATIONS

Fluid: best use mineral oil with viscosity ranging between 10 and 200 cSt.

Filter: see General Informations.

Weight:

- aluminium valves 1.85 kg

- steel valves 3.8 kg

Cartridge used: consult our Technical Department.

Material: made out of high grade steel duly treated and fabricated.

For more information please ask our Technical Department.

Variations and modifications of technical features and dimensions are reserved. HANSA-TMP s.r.l. also reserves the right to stop production of each and any model listed in the catalogue with no notice.

Copyrights on the text contained herein belong to HANSA-TMP s.r.l.. Partial and full reproductions or copies of this catalogue are forbidden.

• RATING DIAGRAMS

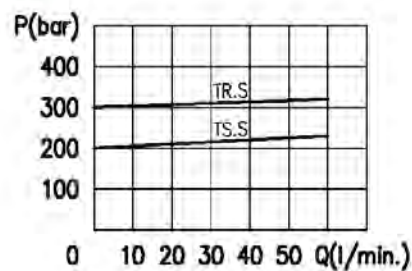

Oil viscosity 46 cSt

• CODE NUMBER

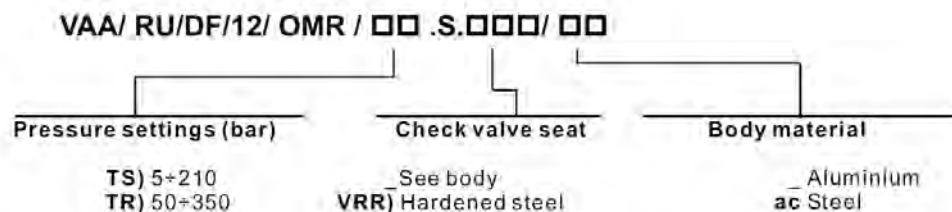

• DIMENSIONS (mm)

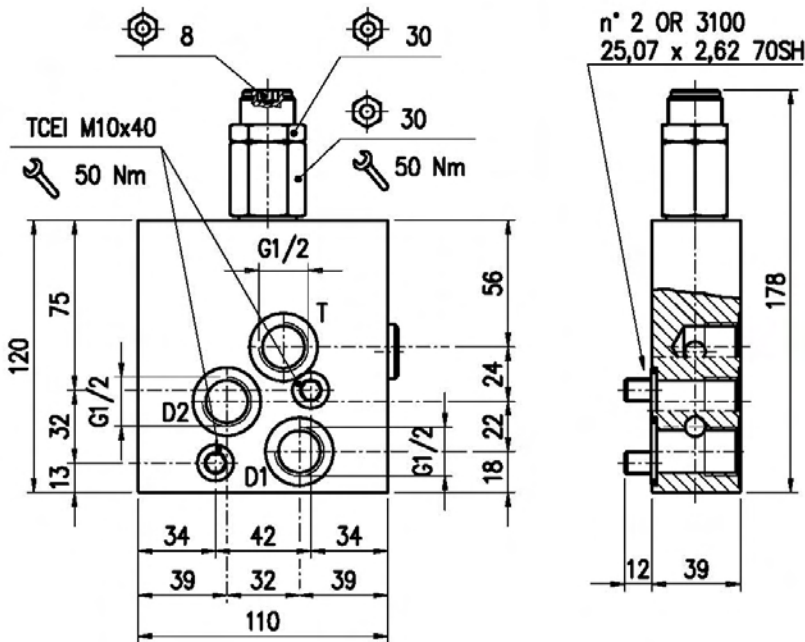

• HYDRAULIC DIAGRAM

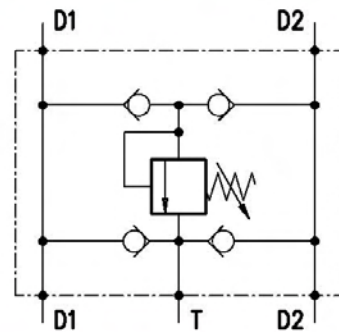

• ASSEMBLY DIAGRAM

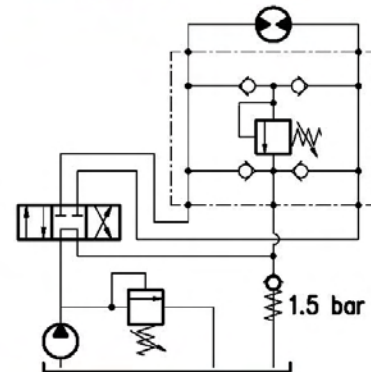

• DESCRIPTION

Antishock valve with anti cavitation and single pressure adjustment. Differential control, conical seat, face mounting for Sauer Danfoss motor OMS series, including O-Rings and screws.

• OPERATION

Allows pressure relief on delivery pipes to engines and cylinders. When the actuator is braking, two check valves allow for anti cavitation on delivery side.

• PERFORMANCE

Maximum flow: 60 l/min.

Maximum Pressure:

- 210 bar (aluminium valve)
- 350 bar (steel valve)

Application range with standard springs:

- 5 ÷ 210 bar, pressure increase = 47 bar/turn (test setting: 150 bar at 5 l/min.) STANDARD
- 50 ÷ 350 bar, pressure increase = 99 bar/turn (test setting: 250 bar at 5 l/min.)

To perform setting of the valve see the pressure drop / flow diagram.

Hysteresis: 85% of the valve setting for 1 L. flow capacity per minute.

Oil leak between P and T: disregardable.

Working temperature:

- min. -25°C max. 90°C with standard BUNAN gaskets
- min. -20°C max. 120°C with optional VITON gaskets

Spare parts KIT:

A) Screws and Seals (Ordering code: 5KTM0OMS02)

B) External Seals for cartridges type VMPD 12 (Ordering code: 5KT1200300)

• CROSS SECTION

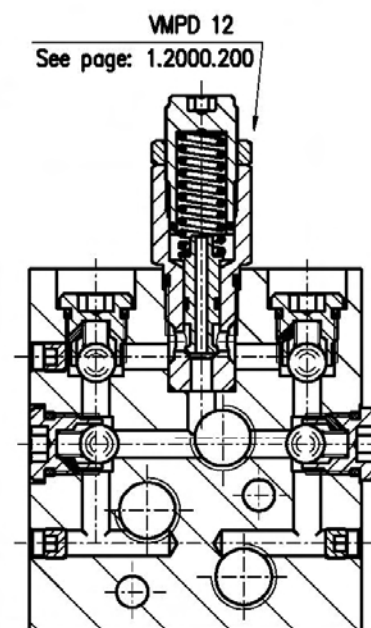

• RECOMMANDATIONS

Fluid: best use mineral oil with viscosity ranging between 10 and 200 cSt.

Filter: see General Informations.

Weight:

- aluminium valves 1.6 kg

- steel valves 3.3 kg

Cartridge used: consult our Technical Department.

Material: made out of high grade steel duly treated and fabricated.

For more information please ask our Technical Department.

Variations and modifications of technical features and dimensions are reserved. HANSA-TMP s.r.l. also reserves the right to stop production of each and any model listed in the catalogue with no notice.

Copyrights on the text contained herein belong to HANSA-TMP s.r.l.. Partial and full reproductions or copies of this catalogue are forbidden.

• RATING DIAGRAMS

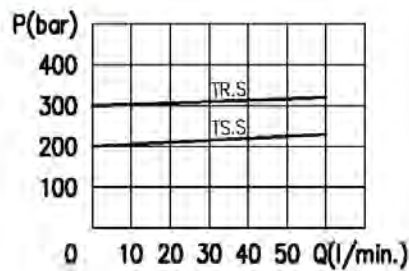

Oil viscosity 46 cSt

• CODE NUMBER

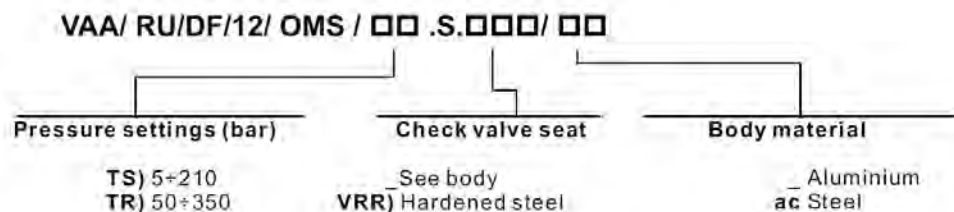

• DIMENSIONS (mm)

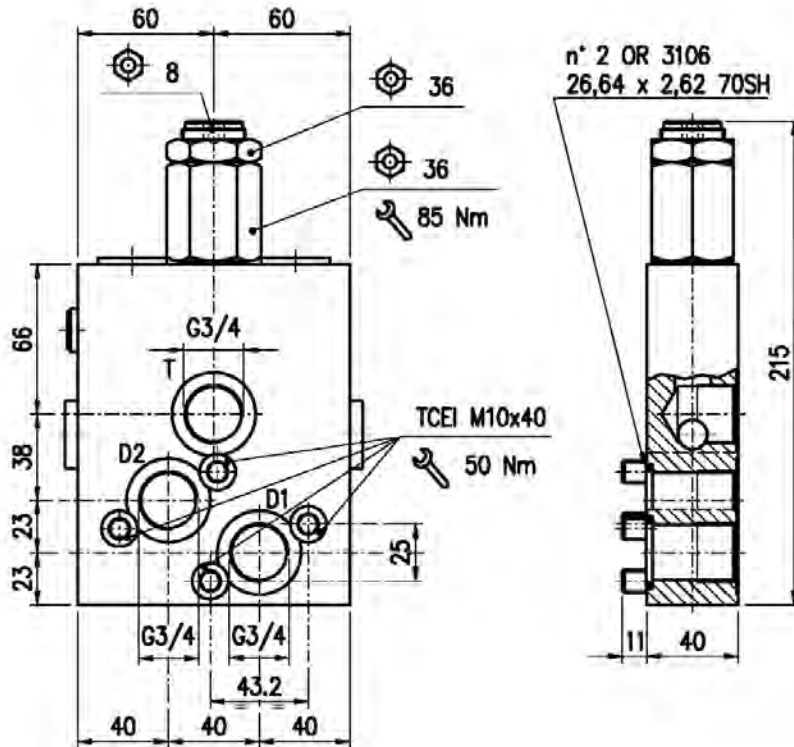

• HYDRAULIC DIAGRAM

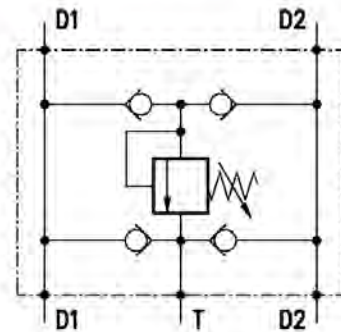

• ASSEMBLY DIAGRAM

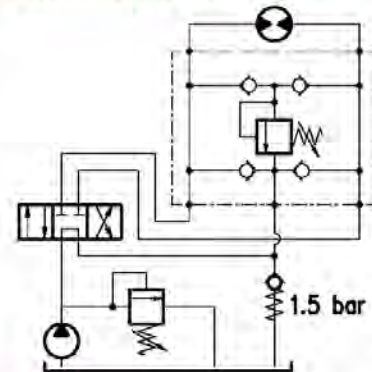

• DESCRIPTION

Antishock valve with anti cavitation and single pressure adjustment, Differential control, conical seat, face mounting for Sauer Danfoss motor OMT series, including O-Rings and screws.

• OPERATION

Allows pressure relief on delivery pipes to engines and cylinders. When the actuator is braking, two check valves allow for anti cavitation on delivery side.

• PERFORMANCE

Maximum flow: 100 l/min.

Maximum Pressure:

- 210 bar (aluminium valve)

- 350 bar (steel valve)

Application range with standard springs:

- 5 ÷ 210 bar, pressure increase = 37 bar/turn (test setting: 150 bar at 5 l/min.) STANDARD

- 50 ÷ 350 bar, pressure increase = 63 bar/turn (test setting: 250 bar at 5 l/min.)

To perform setting of the valve see the pressure drop / flow diagram.

Hysteresis: 85% of the valve setting for 1 L. flow capacity per minute.

Oil leak between P and T: disregardable.

Working temperature:

- min. -25°C max. 90°C with standard BUNAN gaskets

- min. -20°C max. 120°C with optional VITON gaskets

Spare parts KIT:

A) Screws and Seals (Ordering code: 5KTM00MT01)

B) External Seals for cartridges type VMPD 34 (Ordering code: 5KT1200400)

• CROSS SECTION

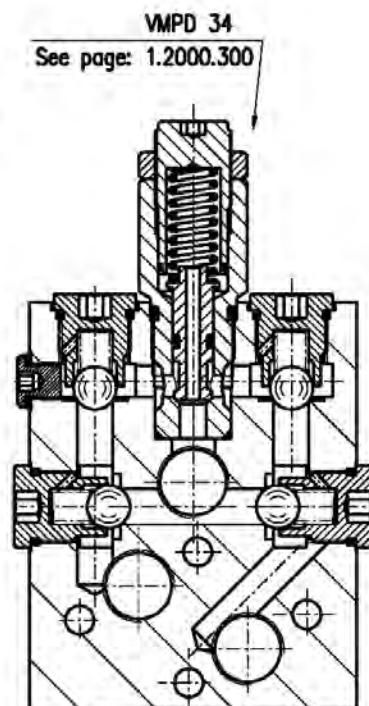

• RECOMMANDATIONS

Fluid: best use mineral oil with viscosity ranging between 10 and 200 cSt.

Filter: see General Informations.

Weight:

- aluminium valves 2.5 kg
- steel valves 4.7 kg

Cartridge used: consult our Technical Department.

Material: made out of high grade steel duly treated and fabricated.

For more information please ask our Technical Department.

Variations and modifications of technical features and dimensions are reserved. HANSA-TMP s.r.l. also reserves the right to stop production of each and any model listed in the catalogue with no notice.

Copyrights on the text contained herein belong to HANSA-TMP s.r.l.. Partial and full reproductions or copies of this catalogue are forbidden.

• **RATING DIAGRAMS**

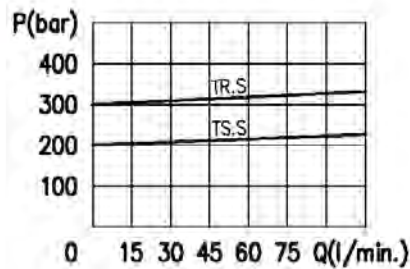

Oil viscosity 46 cSt

• **CODE NUMBER**

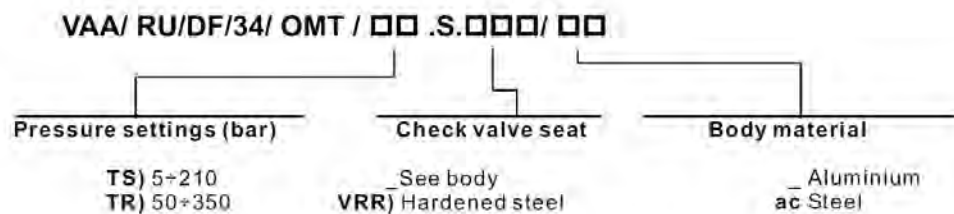

RECOMMENDATIONS

Fluid: best use mineral oil with viscosity ranging between 10 and 200 cSt.

Filter: see General Informations.

Weight:

- aluminium valves 4.75 kg
- steel valves 9.2 kg

Cartridge used: consult our Technical Department.

Material: made out of high grade steel duly treated and fabricated.

For more information please ask our Technical Department.

Variations and modifications of technical features and dimensions are reserved. HANSA-TMP s.r.l. also reserves the right to stop production of each and any model listed in the catalogue with no notice.

Copyrights on the text contained herein belong to HANSA-TMP s.r.l.. Partial and full reproductions or copies of this catalogue are forbidden.

• **RATING DIAGRAMS**

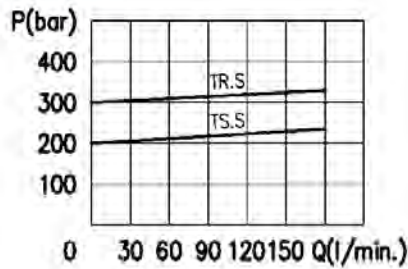

Oil viscosity 46 cSt

• **CODE NUMBER**

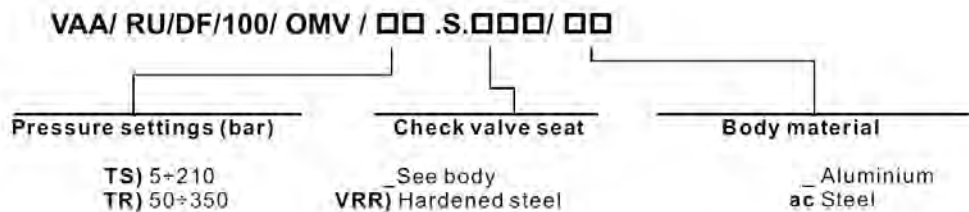

CHECK VALVES INDEX

Description	type	code	page
Anticavitation valve	VANT / F12 / OMS	A.1410.300	64
Shuttle valve, ball type	VTF / OMR 12	A.1450.200	66
Shuttle valve, ball type	VTF / OMS 12	A.1450.300	68

• DIMENSIONS (mm)

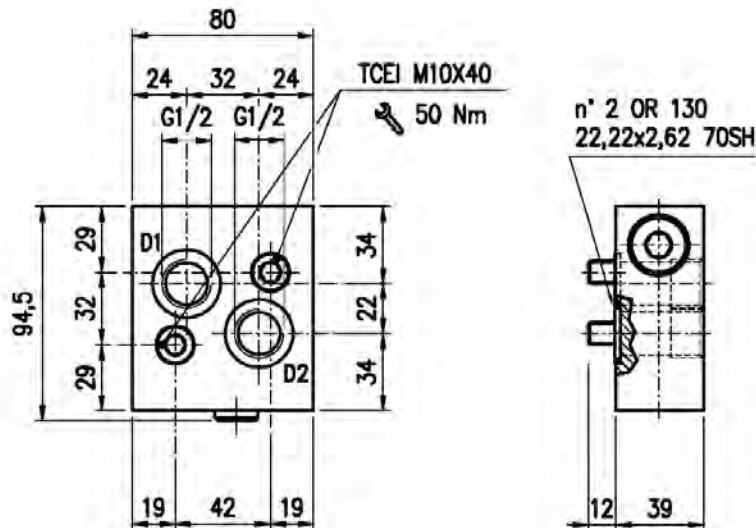

• HYDRAULIC DIAGRAM

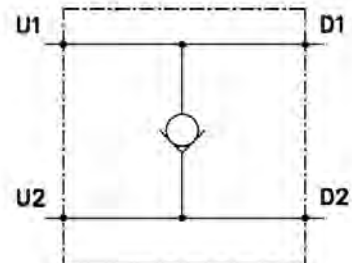

• ASSEMBLY DIAGRAM

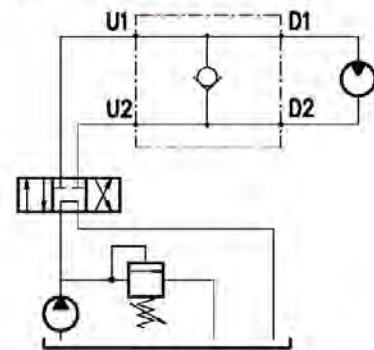

• DESCRIPTION

Anti cavitation valve, face mounting for Sauer Danfoss motor OMS series, including O-Rings and screws.

• OPERATION

When the actuator is braking, the check valve allow for anti cavitation on delivery side.

• PERFORMANCE

Maximum flow: 70 l/min.

Maximum Pressure:

- 210 bar (aluminium valve)

- 350 bar (steel valve)

Hysteresis: 85% of the valve setting for 1 L. flow capacity per minute.

Working temperature:

- min. -25°C max. 90°C with standard BUNAN gaskets

- min. -20°C max. 120°C with optional VITON gaskets

Spare parts KIT:

A) Screws and Seals (Ordering code: 5KTM0OMS00)

• RECOMMANDATIONS

Fluid: best use mineral oil with viscosity ranging between 10 and 200 cSt.

Filter: see page Z.9000.000.

Weight:

- aluminium valves 0.85 kg

- steel valves 2 kg

• CROSS SECTION

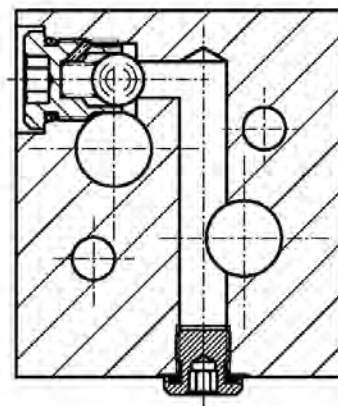

Fluid: best use mineral oil with viscosity ranging between 10 and 200 cSt.

Filter: see General Informations.

Cartridge used: parts in body.

Material: made out of high grade steel duly treated and fabricated.

For more information please ask our Technical Department.

Variations and modifications of technical features and dimensions are reserved. HANSA-TMP s.r.l. also reserves the right to stop production of each and any model listed in the catalogue with no notice.

Copyrights on the text contained herein belong to HANSA-TMP s.r.l.. Partial and full reproductions or copies of this catalogue are forbidden.

• RATING DIAGRAMS

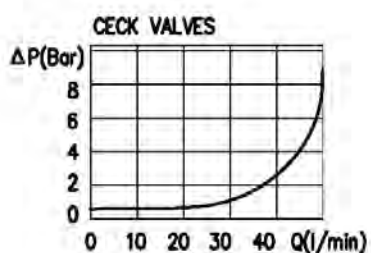

Oil viscosity 46 cSt

• CODE NUMBER

VANT/ F 12 OMS / □□

Body material

— Aluminium
ac Steel

• DIMENSIONS (mm)

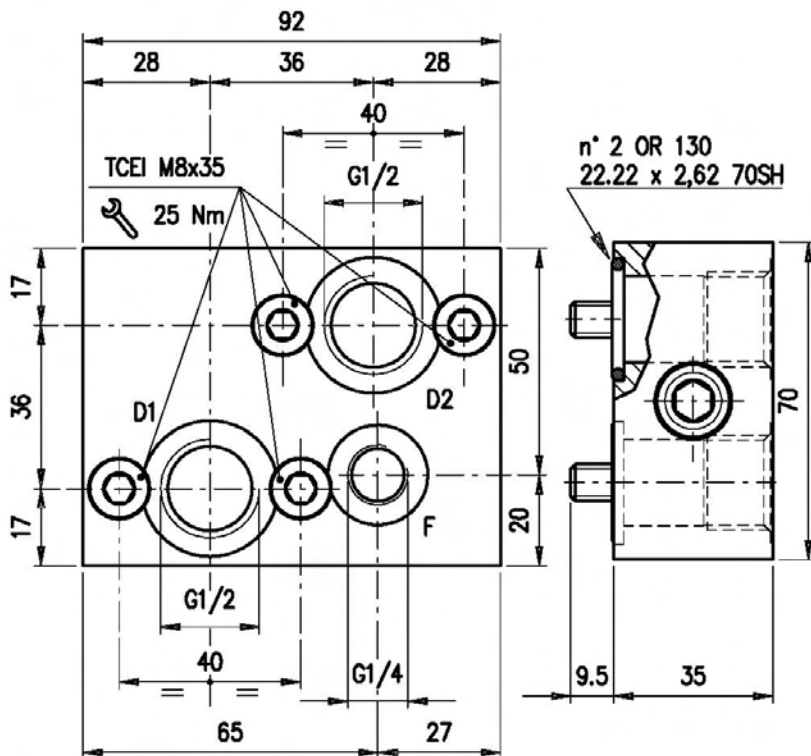

• HYDRAULIC DIAGRAM

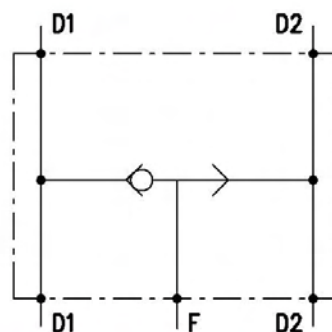

• ASSEMBLY DIAGRAM

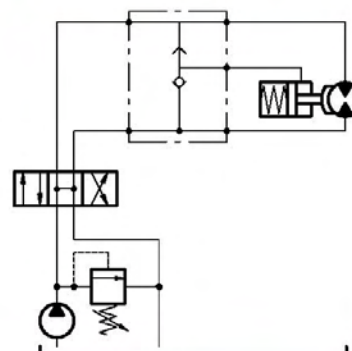

• DESCRIPTION

Shuttle valve, ball type, face mounting for Sauer-Danfoss motor OMR series, including O-Rings and screws.

• OPERATION

Oil flow is produced from D1 to F or D2 to F with priority to the way with the bigger pressure.

• PERFORMANCE

Maximum flow: 50 l/min.

Maximum Pressure:

- 210 bar aluminium valve
- 350 bar steel valve

Working temperature:

- minimum -25°C and max +90°C with standard BUNA gaskets
- minimum -20°C and max +120°C with special VITON gaskets on request

Spare parts KIT:

Screws and Seals (Ordering code: 5KTM00MR00)

• RECOMMENDATIONS

Fluid: best use mineral oil with viscosity ranging between 10 and 200 cSt.

Filter: see page Z.9000.000.

Weight:

- aluminium valves 0.52kg
- steel valves 1.3 kg

• CROSS SECTION

PARTS IN BODY

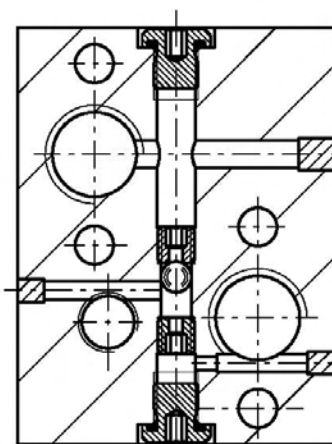

Fluid: best use mineral oil with viscosity ranging between 10 and 200 cSt.

Filter: see General Informations.

Cartridge used: parts in body.

Material: made out of high grade steel duly treated and fabricated.

For more information please ask our Technical Department.

Variations and modifications of technical features and dimensions are reserved. HANSA-TMP s.r.l. also reserves the right to stop production of each and any model listed in the catalogue with no notice.

Copyrights on the text contained herein belong to HANSA-TMP s.r.l.. Partial and full reproductions or copies of this catalogue are forbidden.

• CODE NUMBER

VTF/OMR 12 □□

Body material

_ Aluminium
ac Steel

• DIMENSIONS (mm)

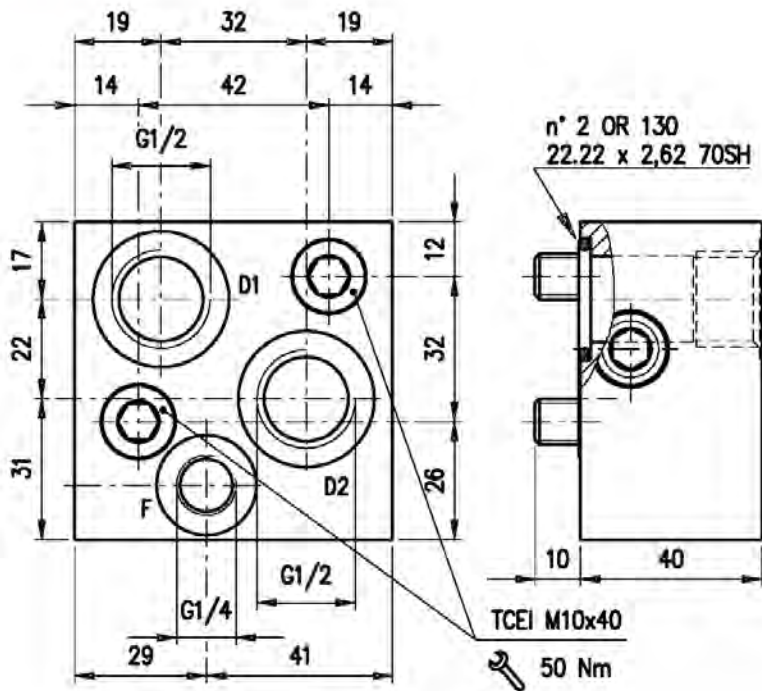

• HYDRAULIC DIAGRAM

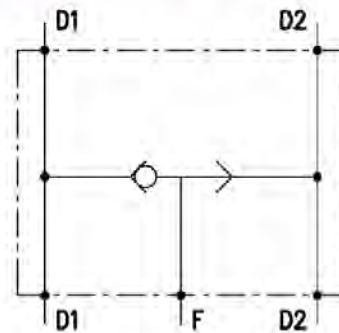

• ASSEMBLY DIAGRAM

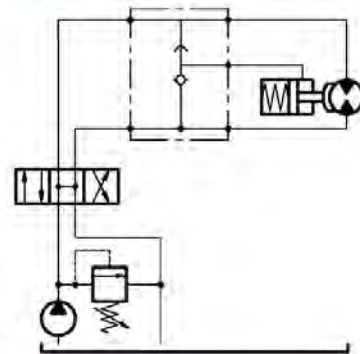

• DESCRIPTION

Shuttle valve, ball type, face mounting for Sauer-Danfoss motor OMS series, including O-Rings and screws.

• OPERATION

Oil flow is produced from D1 to F or D2 to F with priority to the way with the bigger pressure.

• PERFORMANCE

Maximum flow: 50 l/min.

Maximum Pressure:

- 210 bar aluminium valve
- 350 bar steel valve

Working temperature:

- minimum -25°C and max +90°C with standard BUNAgaskets
- minimum -20°C and max +120°C with special VITON gaskets on request

Spare parts KIT:

Screws and Seals (Ordering code: 5KTM0OMS00)

• RECOMMANDATIONS

Fluid: best use mineral oil with viscosity ranging between 10 and 200 cSt.

Filter: see page Z.9000.000.

Weight:

- aluminium valves 0.45 kg
- steel valves 1.3 kg

Material internal components: made out of high grade steel duly treated and fabricated.

• CROSS SECTION

PARTS IN BODY

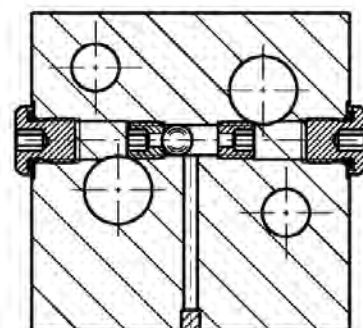

Fluid: best use mineral oil with viscosity ranging between 10 and 200 cSt.

Filter: see General Informations.

Cartridge used: parts in body.

Material: made out of high grade steel duly treated and fabricated.

For more information please ask our Technical Department.

Variations and modifications of technical features and dimensions are reserved. HANSA-TMP s.r.l. also reserves the right to stop production of each and any model listed in the catalogue with no notice.

Copyrights on the text contained herein belong to HANSA-TMP s.r.l.. Partial and full reproductions or copies of this catalogue are forbidden.

• CODE NUMBER

VTF/OMS 12 / □□

Body material

Aluminium
or Steel

OVERCENTER VALVES INDEX

Description	type	code	page
Single Overcenter valve	VOSL / SC / F 12 / OMR	A.1610.200	72
Dual Overcenter valve	VODL / SC / F 12 / OMR	A.1610.250	74
Single Overcenter valve	VOSL / SC / F 12 / OMS	A.1610.300	76
Dual Overcenter valve	VODL / SC / F 12 / OMS	A.1610.350	78
Single Overcenter valve	VOSL / SC / F 34 / OMT	A.1610.400	80
Dual Overcenter valve	VODL / SC / F 34 / OMT	A.1610.450	82
Single Overcenter valve, with brake valve	VOSL / SC / F / A 12 / OMR	A.1620.200	84
Dual Overcenter valve, with brake valve	VODL / SC / F / A 12 / OMR	A.1620.250	86
Single Overcenter valve, with brake valve	VOSL / SC / F / A 12 / OMS	A.1620.300	88
Dual Overcenter valve, with brake valve	VODL / SC / F / A 12 / OMS	A.1620.350	90
Single Overcenter valve, with brake valve	VOSL / SC / F / A 34 / OMT	A.1620.400	92
Dual Overcenter valve, with brake valve	VODL / SC / F / A 34 / OMT	A.1620.450	94
Single Overcenter valve, with brake valve	VOSL / SC / F / A 100 / OMV	A.1620.500	96
Dual Overcenter valve, with brake valve	VODL / SC / F / A 100 / OMV	A.1620.550	98
Dual Overcenter valve,for closed centre	VODL / SC/CC/F / A 12 / OMR/ CC16	A.1640.250	100

• DIMENSIONS (mm)

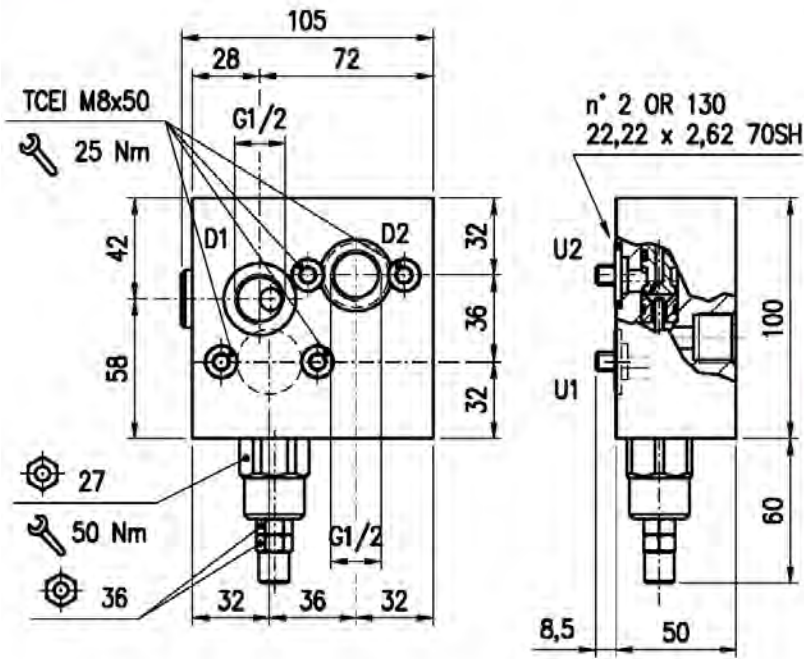

• HYDRAULIC DIAGRAM

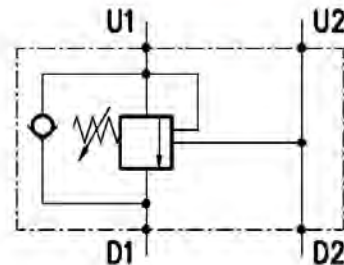

• ASSEMBLY DIAGRAM

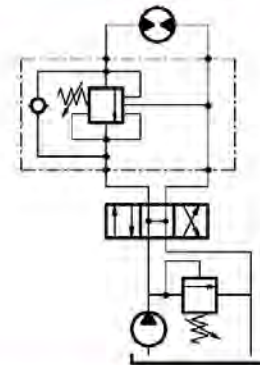

• CROSS SECTION

PARTS IN BODY

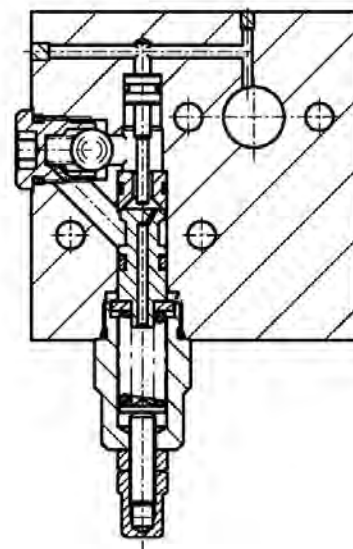

• DESCRIPTION

Single overcenter valves, face mounting for Sauer Danfoss motor OMR series.

• OPERATION

The oil flow is allowed from D1 to U1 and is stopped in the opposite way (from U1 to D1) up to the spring setting value. Free oil flow from U1 to D1 is strictly possible when the pilot pressure in D2 and U2 is strong enough to pilot the valve poppet.

Use the following formula to assert the applicable pilot pressure:

$$(\text{valve setting} - \text{load pressure}) \div \text{pilot ratio} = \text{pilot pressure}$$

For example:

If your pilot ratio is 1:4, your setting pressure is 250 bar and your load pressure is 130 bar then you will need 30 bar pilot pressure in order to displace the load. $((250 \text{ bar} - 130 \text{ bar}) \div 4 = 30 \text{ bar})$.

Should counterpressure arise in D1, the setting value of valve poppet (1:1 ratio) will increase and the pilot pressure be negatively affected (1:1 ratio).

• PERFORMANCE

Maximum flow: 40 l/min

Maximum Pressure:

- Aluminium body: 210 bar

- Steel body: 350 bar

Application range with standard springs:

- 5 - 210 bar pressure increase = 26 bar/turn (test setting: 170 bar at 5 l/min)

- 50 - 350 bar pressure increase = 87 bar/turn (test setting: 280 bar at 5 l/min) STANDARD

Oil leaks from U1 to D1: 0.25 cc/minute (5 drops) at 210 bar and 80% of the spring setting value with oil viscosity of 46 cSt

Pilot ratio:

1:4 (standard type)

**OVERCENTER VALVES (SAUER-DANFOSS MOTOR)
VOSL/SC/F 12/OMR**

Working temperature:

- Minimum -25°C max 90°C with standard BUNAN gaskets
- Minimum -20°C max 120°C with optional VITON gaskets

Spare parts KIT:

Screws and Seals (Ordering code: 5KTM00MR03)

RECOMMENDATIONS

Fluid: best use mineral oil with viscosity ranging between 10 and 200 cSt

Filter: see General Informations.

Weight:

- aluminium valves 1.5 kg
- steel valves 3.5 kg

Material: made out of high-grade steel duly treated and fabricated.

For more information please ask our Technical Department.

Variations and modifications of technical features and dimensions are reserved. HANSA-TMP s.r.l. also reserves the right to stop production of each and any model listed in the catalogue with no notice.

Copyrights on the text contained herein belong to HANSA-TMP s.r.l.. Partial and full reproductions or copies of this catalogue are forbidden.

• RATING DIAGRAMS

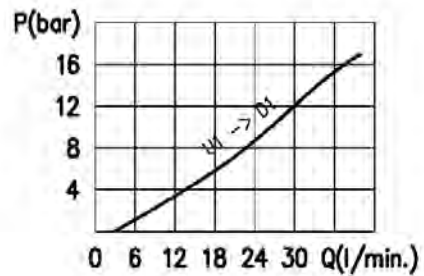
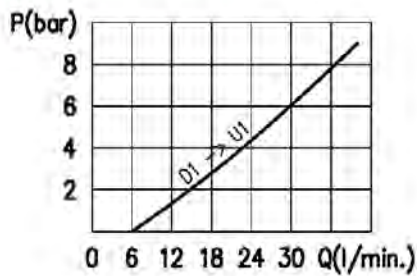

Oil viscosity 46 cSt

• CODE NUMBER

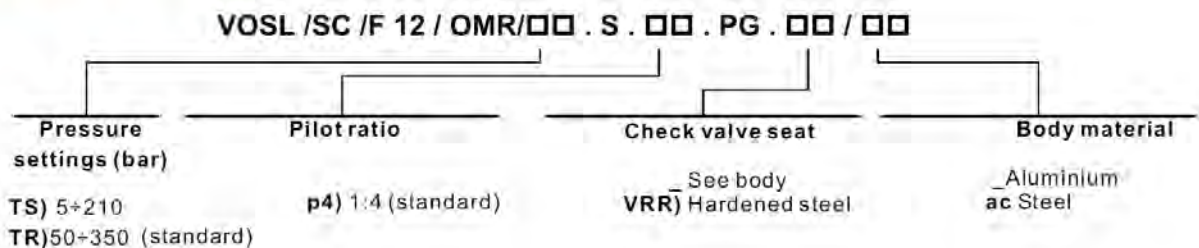

• DIMENSIONS (mm)

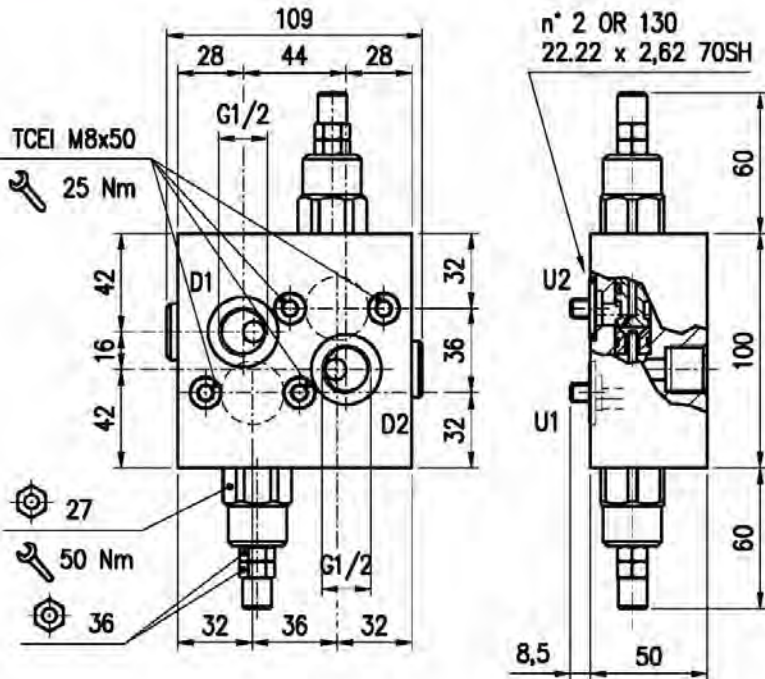

• HYDRAULIC DIAGRAM

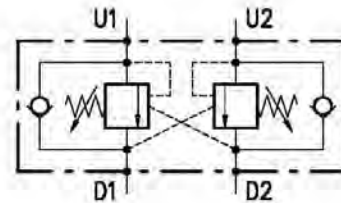

• ASSEMBLY DIAGRAM

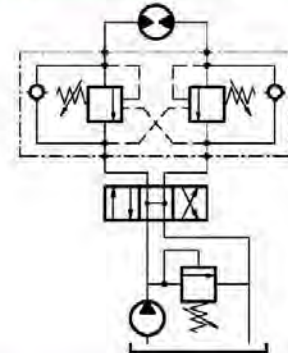

• DESCRIPTION

Dual overcenter valves, face mounting for Sauer Danfoss motor OMR series.

• OPERATION

The oil flow is allowed from D1 (D2) to U1 (U2) and is stopped in the opposite way from U1 (U2) to D1 (D2) up to the spring setting value. Free oil flow from U1 (U2) to D1 (D2) is strictly possible when the pilot pressure in D2 and U2 (D1 and U1) is strong enough to pilot the valve poppet.

Use the following formula to assert the applicable pilot pressure:

$$(\text{valve setting} - \text{load pressure}) \div \text{pilot ratio} = \text{pilot pressure}$$

For example:

If your pilot ratio is 1:4, your setting pressure is 250 bar and your load pressure is 130 bar then you will need 30 bar pilot pressure in order to displace the load. $[(250 \text{ bar} - 130 \text{ bar}) \div 4 = 30 \text{ bar}]$.

Should counterpressure arise in D1 (D2), the setting value of valve poppet (1:1 ratio) will increase and the pilot pressure be negatively affected (1:1 ratio).

• PERFORMANCE

Maximum flow: 40 l/min

Maximum Pressure:

- Aluminium body: 210 bar

- Steel body: 350 bar

Application range with standard springs:

- 5 - 210 bar pressure increase = 26 bar/turn (test setting: 170 bar at 5 l/min)

- 50 - 350 bar pressure increase = 87 bar/turn (test setting: 280 bar at 5 l/min) STANDARD

Oil leaks from U1 (U2) to D1 (D2): 0.25 cc/minute (5 drops) at 210 bar and 80% of the spring

• CROSS SECTION

PARTS IN BODY

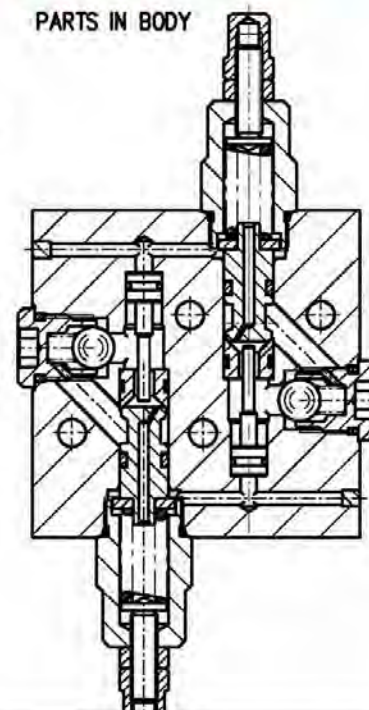

Working temperature:

- Minimum -25°C max 90°C with standard BUNAN gaskets
- Minimum -20°C max 120°C with optional VITON gaskets

Spare parts KIT:

Screws and Seals (Ordering code: 5KT00MR03)

• **RECOMMANDATIONS**

Fluid: best use mineral oil with viscosity ranging between 10 and 200 cSt

Filter: see General Informations.

Weight:

- aluminium valves 1.75 kg
- steel valves 3.75 kg

Material: made out of high-grade steel duly treated and fabricated.

For more information please ask our Technical Department.

Variations and modifications of technical features and dimensions are reserved. HANSA-TMP s.r.l. also reserves the right to stop production of each and any model listed in the catalogue with no notice.

Copyrights on the text contained herein belong to HANSA-TMP s.r.l.. Partial and full reproductions or copies of this catalogue are forbidden.

• **RATING DIAGRAMS**

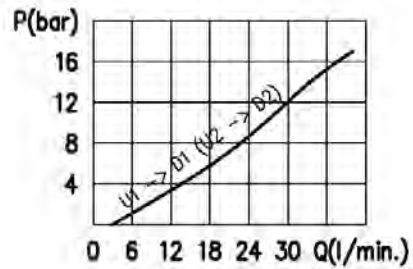
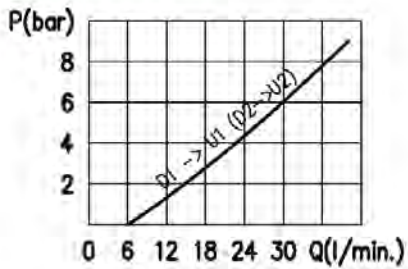

Oil viscosity 46 cSt

• **CODE NUMBER**

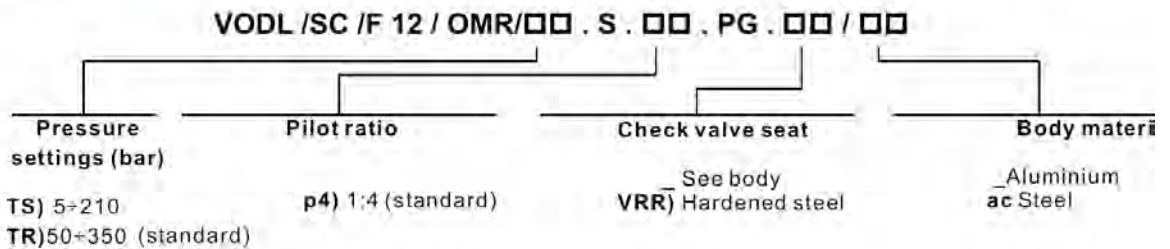

• DIMENSIONS (mm)

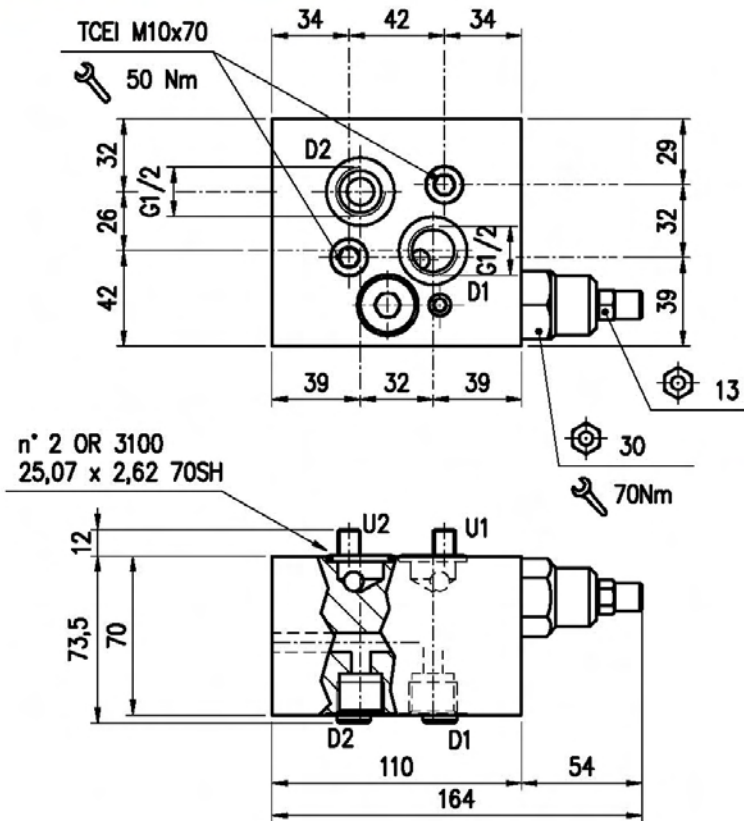

• HYDRAULIC DIAGRAM

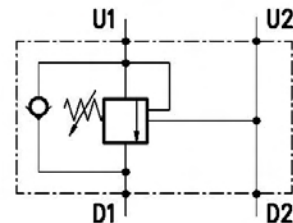

• ASSEMBLY DIAGRAM

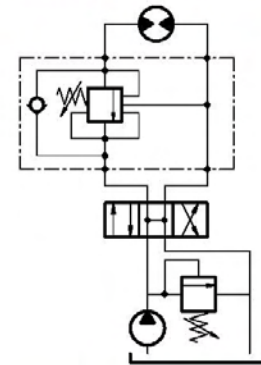

• DESCRIPTION

Single overcenter valves, face mounting for Sauer Danfoss motor OMS series.

• OPERATION

The oil flow is allowed from D1 to U1 and is stopped in the opposite way (from U1 to D1) up to the spring setting value. Free oil flow from U1 to D1 is strictly possible when the pilot pressure in D2 and U2 is strong enough to pilot the valve poppet.

Use the following formula to assert the applicable pilot pressure:

$$(\text{valve setting} - \text{load pressure}) \div \text{pilot ratio} = \text{pilot pressure}$$

For example:

If your pilot ratio is 1:3, your setting pressure is 250 bar and your load pressure is 130 bar then you will need 30 bar pilot pressure in order to displace the load. $[(250 \text{ bar} - 130 \text{ bar}) \div 3 = 40 \text{ bar}]$.

Should counterpressure arise in D1, the setting value of valve poppet (1:1 ratio) will increase and the pilot pressure be negatively affected (1:1 ratio).

• PERFORMANCE

Maximum flow: 70 l/min

Maximum Pressure:

- Aluminium body: 210 bar
- Steel body: 350 bar

Application range with standard springs:

- 5 - 210 bar pressure increase = 36 bar/turn (test setting: 170 bar at 5 l/min)
- 50 - 350 bar pressure increase = 90 bar/turn (test setting: 280 bar at 5 l/min) STANDARD

Oil leaks from U1 to D1: 0.25 cc/minute (5 drops) at 210 bar and 80% of the spring setting value with oil viscosity of 46 cSt

Pilot ratio:

- 1:4 (standard type)

• CROSS SECTION

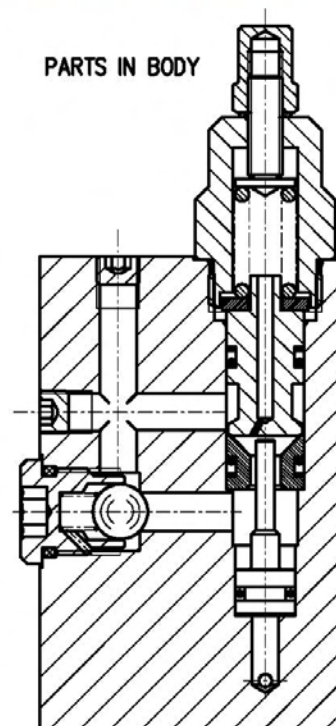

**OVERCENTER VALVES (SAUER-DANFOSS MOTOR)
VOSL/SC/F 12/OMS**

- 1:7 (on request only)

Working temperature

- Minimum -25°C max 90°C with standard BUNAN gaskets
- Minimum -20°C max 120°C with optional VITON gaskets

Spare parts KIT:

Screws and Seals (Ordering code: 5KTM0OMS03)

• **RECOMMANDATIONS**

Fluid: best use mineral oil with viscosity ranging between 10 and 200 cSt

Filter: see General Informations.

Weight:

- aluminium valves 2.2 kg
- steel valves 5.2 kg

Material: made out of high-grade steel duly treated and fabricated.

For more information please ask our Technical Department.

Variations and modifications of technical features and dimensions are reserved. HANSA-TMP s.r.l. also reserves the right to stop production of each and any model listed in the catalogue with no notice.

Copyrights on the text contained herein belong to HANSA-TMP s.r.l.. Partial and full reproductions or copies of this catalogue are forbidden.

• **RATING DIAGRAMS**

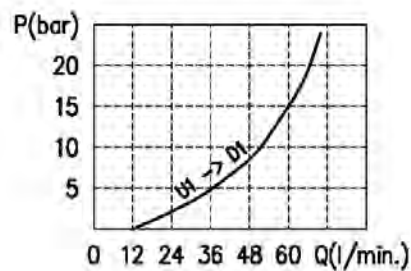
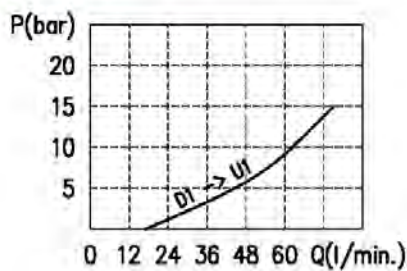

Oil viscosity 46 cSt

• **CODE NUMBER**

VOSL / SC / F 12 / OMS / □□ . S . □□ . PG . □□ / □□

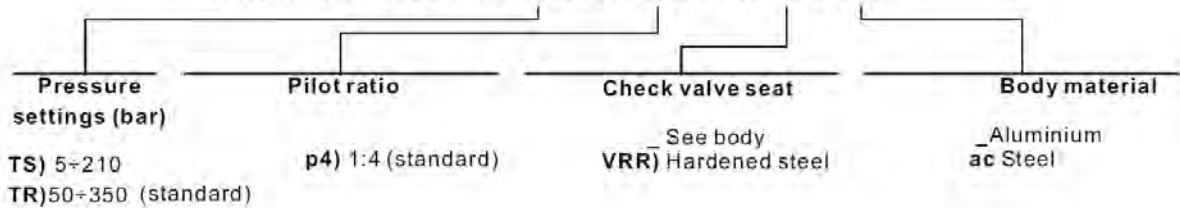

• DIMENSIONS (mm)

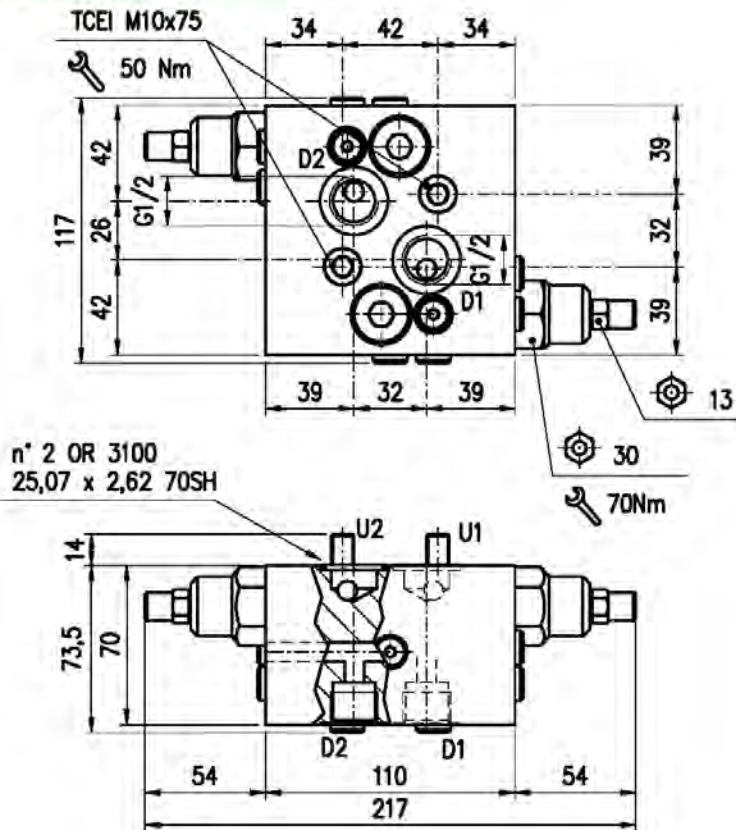

• HYDRAULIC DIAGRAM

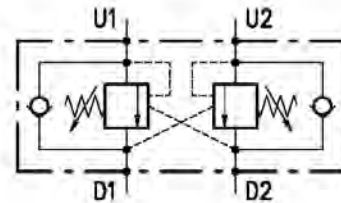

• ASSEMBLY DIAGRAM

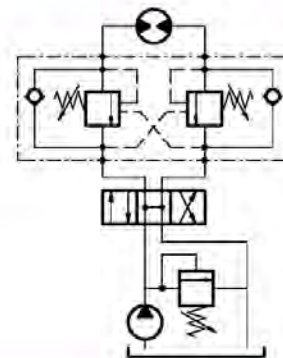

• DESCRIPTION

Dual overcenter valves, face mounting for Sauer Danfoss motor OMS series.

• OPERATION

The oil flow is allowed from D1 (D2) to U1 (U2) and is stopped in the opposite way from U1 (U2) to D1 (D2) up to the spring setting value. Free oil flow from U1 (U2) to D1 (D2) is strictly possible when the pilot pressure in D2 and U2 (D1 and U1) is strong enough to pilot the valve poppet.

Use the following formula to assert the applicable pilot pressure:

$$(\text{valve setting} - \text{load pressure}) \div \text{pilot ratio} = \text{pilot pressure}$$

For example:

If your pilot ratio is 1:7, your setting pressure is 250 bar and your load pressure is 130 bar then you will need 30 bar pilot pressure in order to displace the load. $[(250 \text{ bar} - 130 \text{ bar}) \div 7 = 17 \text{ bar}]$.

Should counterpressure arise in D1 (D2), the setting value of valve poppet (1:1 ratio) will increase and the pilot pressure be negatively affected (1:1 ratio).

• PERFORMANCE

Maximum flow: 70 l/min

Maximum Pressure:

- Aluminium body: 210 bar

- Steel body: 350 bar

Application range with standard springs:

- 5 - 210 bar pressure increase = 36 bar/turn (test setting: 170 bar at 5 l/min)

- 50 - 350 bar pressure increase = 90 bar/turn (test setting: 280 bar at 5 l/min) STANDARD

Oil leaks from U1 (U2) to D1 (D2): 0.25 cc/minute (5 drops) at 210 bar and 80% of the spring setting value with oil viscosity of 46 cSt

• CROSS SECTION

PARTS IN BODY

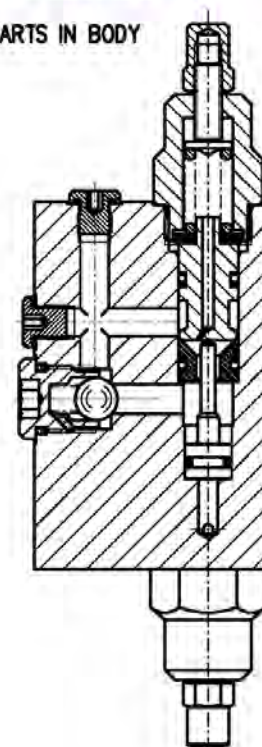

**OVERCENTER VALVES (SAUER-DANFOSS MOTOR)
VODL/SC/F 12/OMS**

Pilot ratio:

- 1:7 (standard type)
- 1:3 (on request only)

Working temperature:

- Minimum -25°C max 90°C with standard BUNANGaskets
- Minimum -20°C max 120°C with optional VITONGaskets

Spare parts KIT:

Screws and Seals (Ordering code: 5KTM00MS05)

• **RECOMMANDATIONS**

Fluid: best use mineral oil with viscosity ranging between 10 and 200 cSt

Filter: see General Informations.

Weight:

aluminium valves 2.6 kg
steel valves 5.6 kg

Material: made out of high-grade steel duly treated and fabricated.

For more information please ask our Technical Department.

Variations and modifications of technical features and dimensions are reserved. HANSA-TMP s.r.l. also reserves the right to stop production of each and any model listed in the catalogue with no notice.

Copyrights on the text contained herein belong to HANSA-TMP s.r.l.. Partial and full reproductions or copies of this catalogue are forbidden.

• **RATING DIAGRAMS**

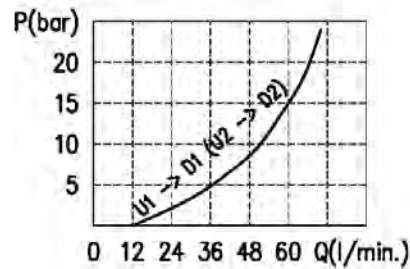
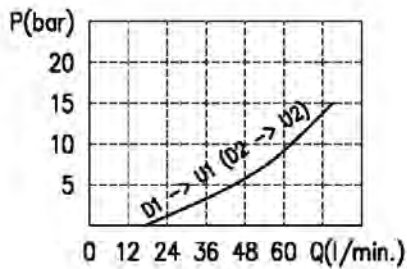

Oil viscosity 46 cSt

• **CODE NUMBER**

VODL / SC / F 12 / OMS / □□ . S . □□ . PG . □□ / □□

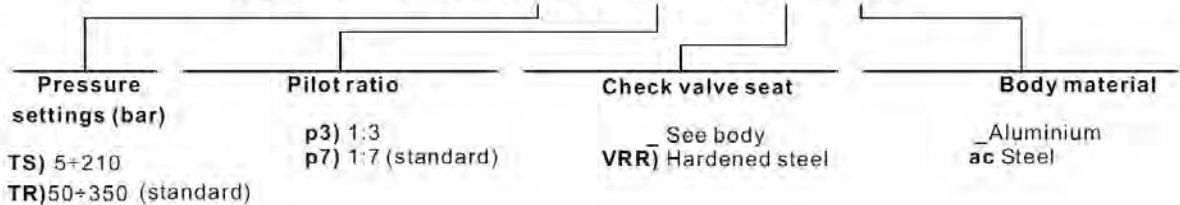

• DIMENSIONS (mm)

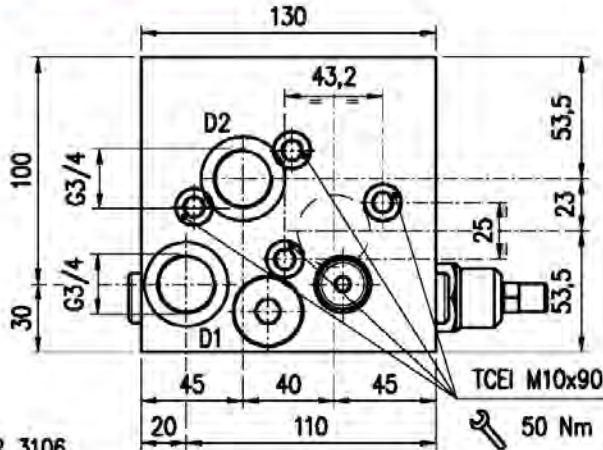

n° 2 OR 3106
26,64 x 2,62 70SH

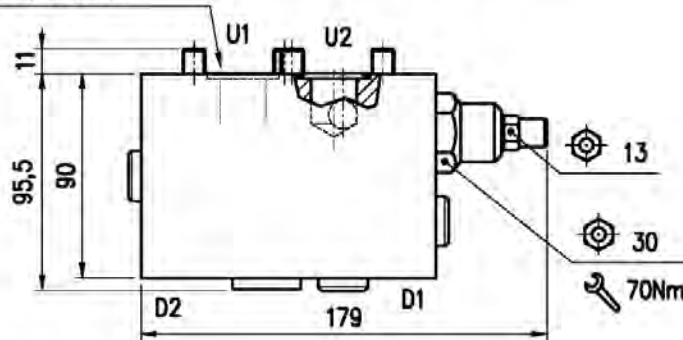

• HYDRAULIC DIAGRAM

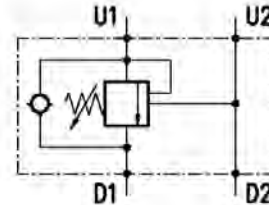

• ASSEMBLY DIAGRAM

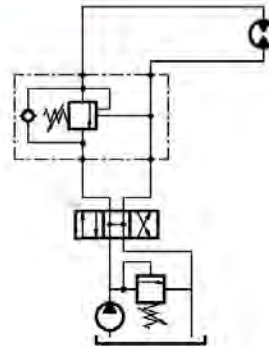

• DESCRIPTION

Single overcenter valves, face mounting for Sauer Danfoss motor OMT series.

• OPERATION

The oil flow is allowed from D1 to U1 and is stopped in the opposite way from U1 to D1 up to the spring setting value. Free oil flow from U1 to D1 is strictly possible when the pilot pressure in D2 and U2 is strong enough to pilot the valve poppet.

Use the following formula to assert the applicable pilot pressure:

$$(\text{valve setting} - \text{load pressure}) \div \text{pilot ratio} = \text{pilot pressure}$$

For example:

If your pilot ratio is 1:7, your setting pressure is 250 bar and your load pressure is 130 bar then you will need 30 bar pilot pressure in order to displace the load. $[(250 \text{ bar} - 130 \text{ bar}) \div 7 = 17 \text{ bar}]$.

Should counterpressure arise in D1 (D2), the setting value of valve poppet (1:1 ratio) will increase and the pilot pressure be negatively affected (1:1 ratio).

• PERFORMANCE

Maximum flow: 120 l/min

Maximum Pressure:

- aluminium body: 210 bar

- steel body: 350 bar

Application range with standard springs:

- 5 - 210 bar pressure increase = 36 bar/turn (test setting: 170 bar at 5 l/min)

- 50 - 350 bar pressure increase = 90 bar/turn (test setting: 280 bar at 5 l/min) STANDARD

Oil leaks from U1 to D1: 0.25 cc/minute (5 drops) at 210 bar and 80% of the spring setting value with oil viscosity of 46 cSt

Pilot ratio: 1:7

• CROSS SECTION

PARTS IN BODY

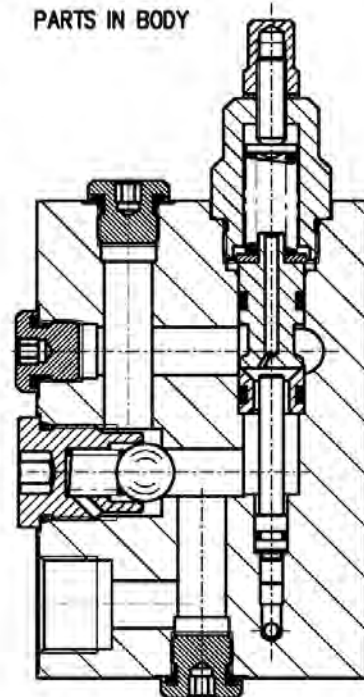

Working temperature:

- minimum -25°C max 90°C with standard BUNAN gaskets
- minimum -20°C max 120°C with optional VITON gaskets

Spare parts KIT:

screws and seals (Ordering code:5KT.....)

• **RECOMMANDATIONS**

Fluid: best use mineral oil with viscosity ranging between 10 and 200 cSt

Filter: see General Informations.

Weight:

- aluminium valves 4.5 kg
- steel valves 9.5 kg

Material: made out of high-grade steel duly treated and fabricated.

For more information please ask our Technical Department.

Variations and modifications of technical features and dimensions are reserved. HANSA-TMP s.r.l. also reserves the right to stop production of each and any model listed in the catalogue with no notice.

Copyrights on the text contained herein belong to HANSA-TMP s.r.l. Partial and full reproductions or copies of this catalogue are forbidden.

• **RATING DIAGRAMS**

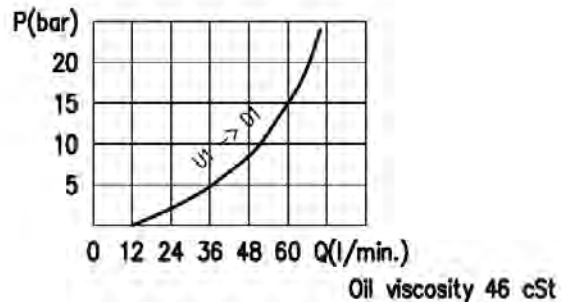
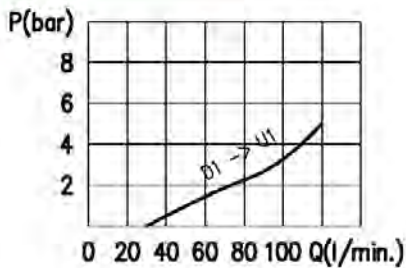

• **CODE NUMBER**

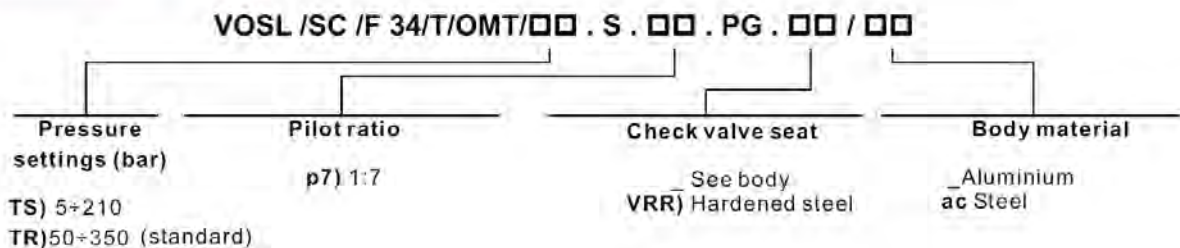

• DIMENSIONS (mm)

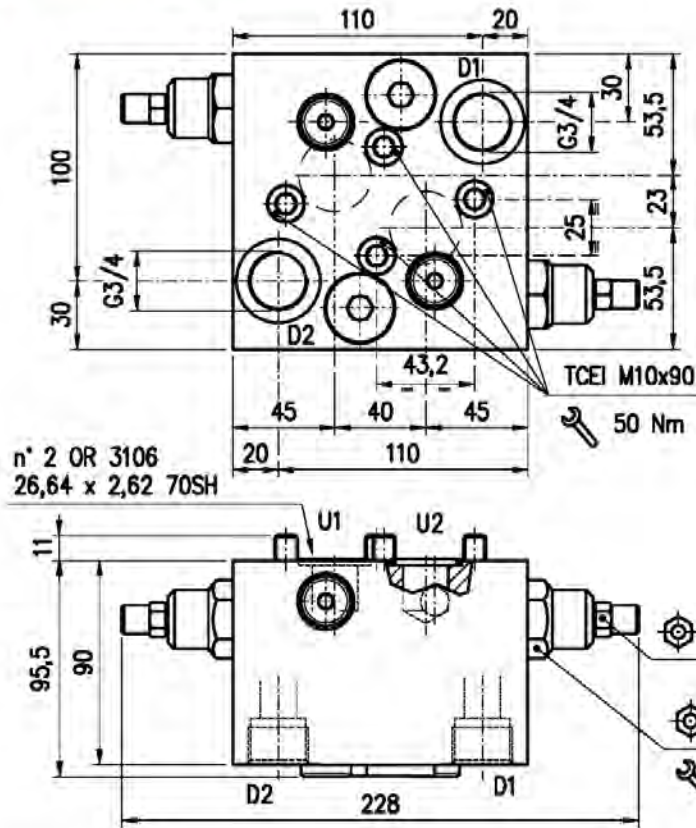

• HYDRAULIC DIAGRAM

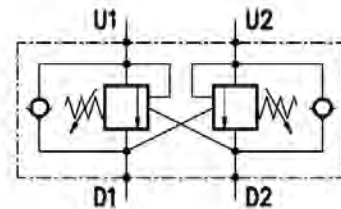

• ASSEMBLY DIAGRAM

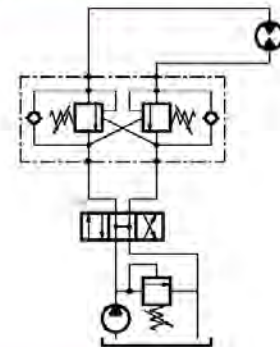

• DESCRIPTION

Dual overcenter valves, face mounting for Sauer Danfoss motor OMT series

• OPERATION

The oil flow is allowed from D1 (D2) to U1 (U2) and is stopped in the opposite way from U1 (U2) to D1 (D2) up to the spring setting value. Free oil flow from U1 (U2) to D1 (D2) is strictly possible when the pilot pressure in D2 and U2 (D1 and U1) is strong enough to pilot the valve poppet.

Use the following formula to assert the applicable pilot pressure:

$$(\text{valve setting} - \text{load pressure}) \div \text{pilot ratio} = \text{pilot pressure}$$

For example:

If your pilot ratio is 1:3, your setting pressure is 250 bar and your load pressure is 130 bar then you will need 30 bar pilot pressure in order to displace the load. $[(250 \text{ bar} - 130 \text{ bar}) \div 3 = 40 \text{ bar}]$.

Should counterpressure arise in D1 (D2), the setting value of valve poppet (1:1 ratio) will increase and the pilot pressure be negatively affected (1:1 ratio).

• PERFORMANCE

Maximum flow: 120 l/min

Maximum Pressure:

- aluminium body: 210 bar
- steel body: 350 bar

Application range with standard springs:

- 5 - 210 bar pressure increase = 36 bar/turn (test setting: 170 bar at 5 l/min)
- 50 - 350 bar pressure increase = 90 bar/turn (test setting: 280 bar at 5 l/min) STANDARD

Oil leaks from U1 (U2) to D1 (D2): 0.25 cc/minute (5 drops) at 210 bar and 80% of the spring setting value with oil viscosity of 46 cSt

Pilot ratio:

- 1:3 (standard type)
- 1:7 (on request only)

• CROSS SECTION

PARTS IN BODY

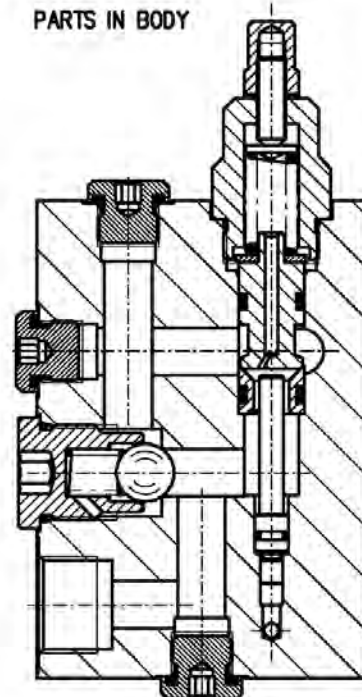

**OVERCENTER VALVES (SAUER-DANFOSS MOTOR)
VODL/SC/F 34/OMT**

Working temperature:

- minimum -25°C max 90°C with standard BUNANgaskets
- minimum -20°C max 120°C with optional VITONgaskets

Spare parts KIT:

screws and seals (Ordering code: 5KTM00MT03)

• **RECOMMANDATIONS**

Fluid: best use mineral oil with viscosity ranging between 10 and 200 cSt

Filter: see General Informations.

Weight:

- aluminium valves 4.5 kg
- steel valves 9.5 kg

Material: made out of high-grade steel duly treated and fabricated.

For more information please ask our Technical Department.

Variations and modifications of technical features and dimensions are reserved. HANSA-TMP s.r.l. also reserves the right to stop production of each and any model listed in the catalogue with no notice.

Copyrights on the text contained herein belong to HANSA-TMP s.r.l.. Partial and full reproductions or copies of this catalogue are forbidden.

• **RATING DIAGRAMS**

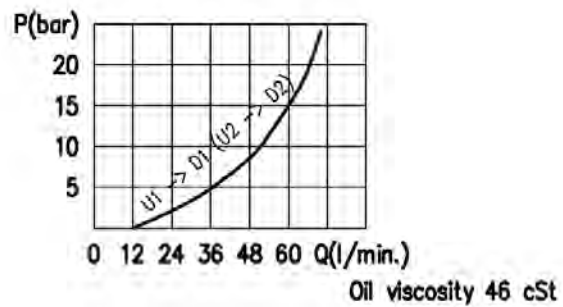
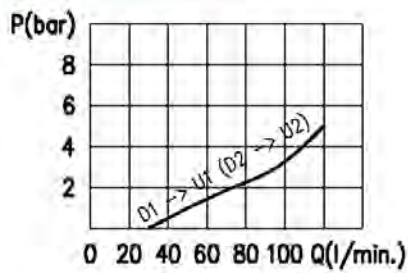

• **CODE NUMBER**

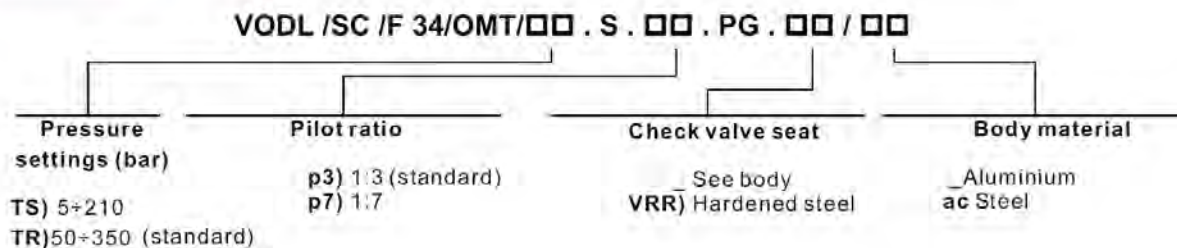

• DIMENSIONS (mm)

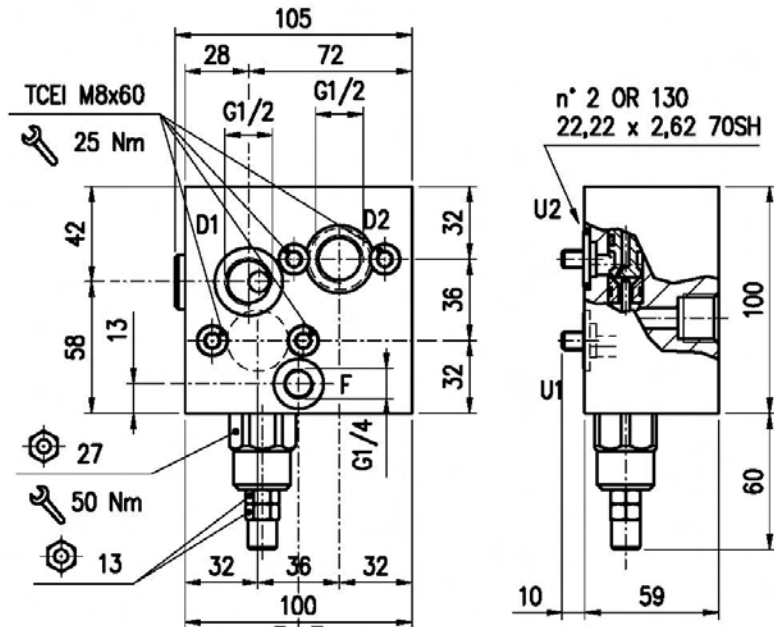

• HYDRAULIC DIAGRAM

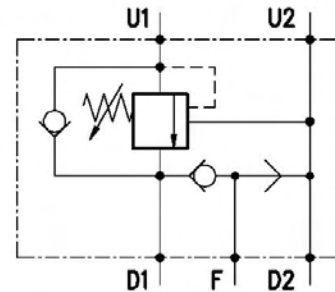

• ASSEMBLY DIAGRAM

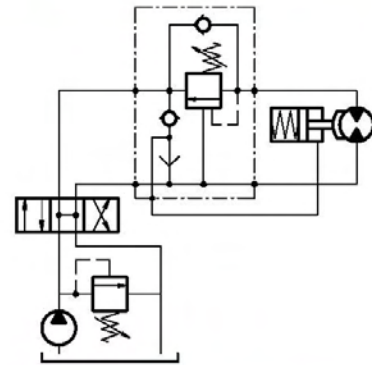

• DESCRIPTION

Single overcenter valves, face mounting for Sauer Danfoss motor OMR series with connection gate for hydraulic brake release.

• OPERATION

The oil flow is allowed from D1 to U1 and is stopped in the opposite way (from U1 to D1) up to the spring setting value. Free oil flow from U1 to D1 is strictly possible when the pilot pressure in D2 and U2 is strong enough to pilot the valve poppet.

Use the following formula to assert the applicable pilot pressure:

$$(\text{valve setting} - \text{load pressure}) \div \text{pilot ratio} = \text{pilot pressure}$$

For example:

If your pilot ratio is 1:3, your setting pressure is 250 bar and your load pressure is 130 bar then you will need 30 bar pilot pressure in order to displace the load. $[(250 \text{ bar} - 130 \text{ bar}) \div 3 = 40 \text{ bar}]$.

Should counterpressure arise in D1, the setting value of valve poppet (1:1 ratio) will increase and the pilot pressure be negatively affected (1:1 ratio).

The special shuttle valve allows releasing of the hydraulic parking brakes.

• PERFORMANCE

Maximum flow: 40 l/min

Maximum Pressure:

- Aluminium body: 210 bar

- Steel body: 350 bar

Application range with standard springs:

- 5 - 210 bar pressure increase = 26 bar/turn (test setting: 170 bar at 5 l/min)

- 50 - 350 bar pressure increase = 87 bar/turn (test setting: 280 bar at 5 l/min) STANDARD

Oil leaks from U1 to D1: 0.25 cc/minute (5 drops) at 210 bar and 80% of the spring setting value with oil viscosity of 46 cSt

Pilot ratio: 1:3 (standard type)

• CROSS SECTION

PARTS IN BODY

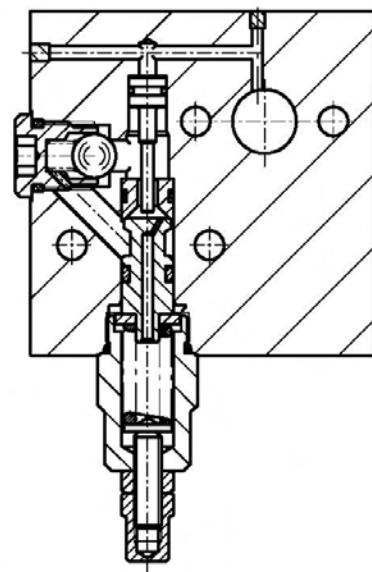

Working temperature:

- Minimum -25°C max 90°C with standard BUNAN gaskets
- Minimum -20°C max 120°C with optional VITON gaskets

Spare parts KIT:

Screws and Seals (Ordering code: 5KTM00MR02)

• **RECOMMANDATIONS**

Fluid: best use mineral oil with viscosity ranging between 10 and 200 cSt

Filter: see General Informations.

Weight:

aluminium valves 1.7 kg
 steel valves 3.6 kg

Material: made out of high-grade steel duly treated and fabricated.

For more information please ask our Technical Department.

Variations and modifications of technical features and dimensions are reserved. HANSA-TMP s.r.l. also reserves the right to stop production of each and any model listed in the catalogue with no notice.

Copyrights on the text contained herein belong to HANSA-TMP s.r.l.. Partial and full reproductions or copies of this catalogue are forbidden.

• **RATING DIAGRAMS**

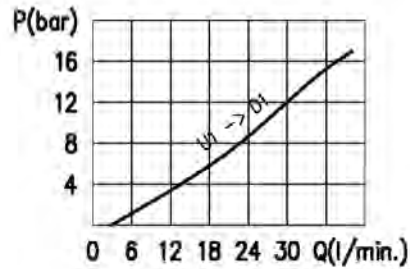
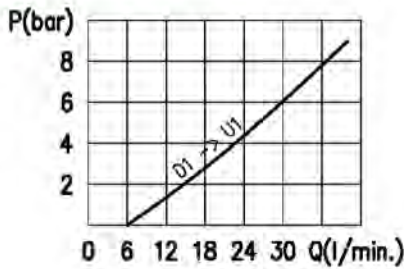

Oil viscosity 46 cSt

• **CODE NUMBER**

VOSL / SC / F / A 12 / OMR / □□ . S . □□ . PG . □□ / □□

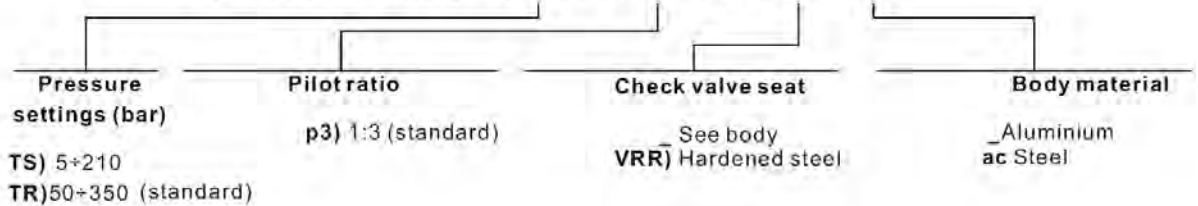

• DIMENSIONS (mm)

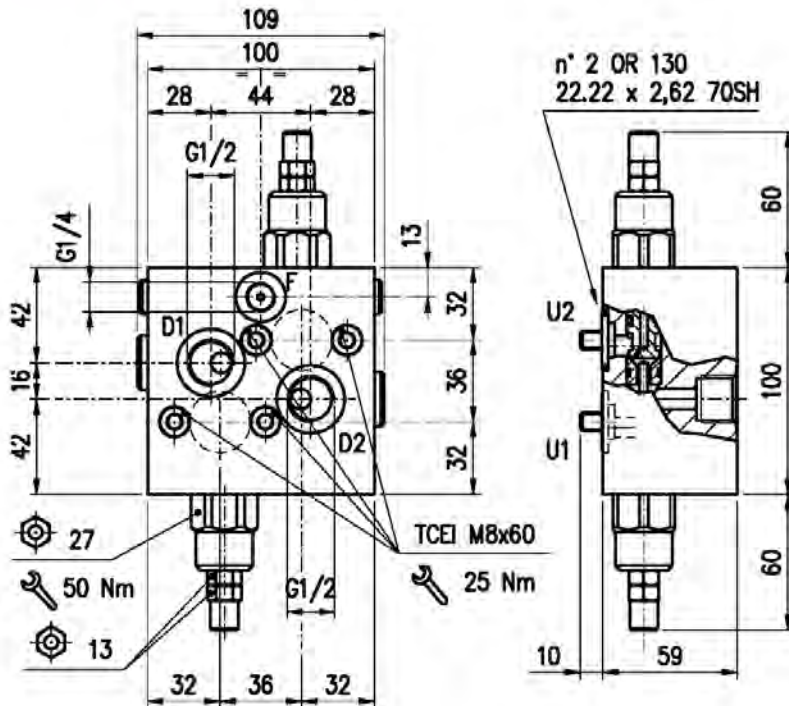

• HYDRAULIC DIAGRAM

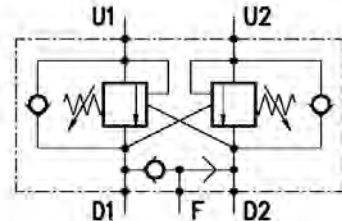

• ASSEMBLY DIAGRAM

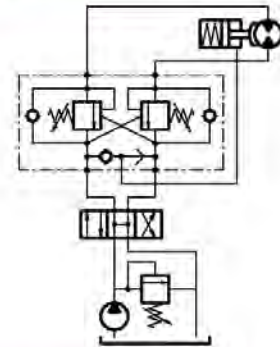

• DESCRIPTION

Dual overcenter valves, face mounting for Sauer Danfoss motor OMR series with connection gate for hydraulic brake release.

• OPERATION

The oil flow is allowed from D1 (D2) to U1 (U2) and is stopped in the opposite way from U1 (U2) to D1 (D2) up to the spring setting value. Free oil flow from U1 (U2) to D1 (D2) is strictly possible when the pilot pressure in D2 and U2 (D1 and U1) is strong enough to pilot the valve poppet.

Use the following formula to assert the applicable pilot pressure:

$$(\text{valve setting} - \text{load pressure}) \div \text{pilot ratio} = \text{pilot pressure}$$

For example:

If your pilot ratio is 1:3, your setting pressure is 250 bar and your load pressure is 130 bar then you will need 30 bar pilot pressure in order to displace the load. $((250 \text{ bar} - 130 \text{ bar}) \div 3 = 40 \text{ bar})$.

Should counterpressure arise in D1 (D2), the setting value of valve poppet (1:1 ratio) will increase and the pilot pressure be negatively affected (1:1 ratio).

The special shuttle valve allows releasing of the hydraulic parking brakes.

• PERFORMANCE

Maximum flow: 40 l/min

Maximum Pressure:

- Aluminium body: 210 bar
- Steel body: 350 bar

Application range with standard springs:

- 5 - 210 bar pressure increase = 26 bar/turn (test setting: 170 bar at 5 l/min)
- 50 - 350 bar pressure increase = 87 bar/turn (test setting: 280 bar at 5 l/min) STANDARD

Oil leaks from U1 (U2) to D1 (D2): 0.25 cc/minute (5 drops) at 210 bar and 80% of the spring setting value with oil viscosity of 46 cSt

• CROSS SECTION

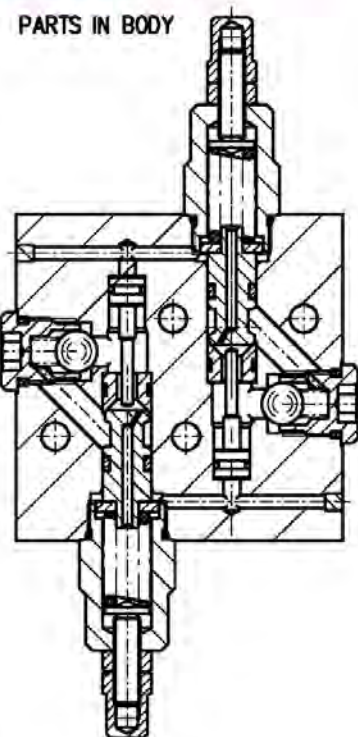

**OVERCENTER VALVES (SAUER-DANFOSS MOTOR)
VODL/SC/F/A 12/OMR**

Pilot ratio: 1:3 (standard type)

Working temperature:

- Minimum -25°C max 90°C with standard BUNANGaskets
- Minimum -20°C max 120°C with optional VITONGaskets

Spare parts KIT:

Screws and Seals (Ordering code: 5KT00MR02)

• **RECOMMANDATIONS**

Fluid: best use mineral oil with viscosity ranging between 10 and 200 cSt

Filter: see General Informations.

Weight:

- aluminium valves 2 kg
- steel valves 3.8 kg

Material:

made out of high-grade steel duly treated and fabricated.

For more information please ask our Technical Department.

Variations and modifications of technical features and dimensions are reserved. HANSA-TMP s.r.l. also reserves the right to stop production of each and any model listed in the catalogue with no notice.

Copyrights on the text contained herein belong to HANSA-TMP s.r.l.. Partial and full reproductions or copies of this catalogue are forbidden.

• **RATING DIAGRAMS**

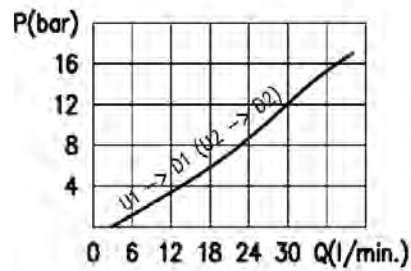
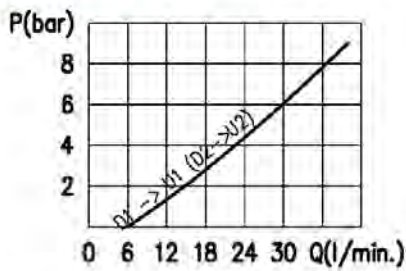

Oil viscosity 46 cSt

• **CODE NUMBER**

VODL / SC / F / A 12 / OMR / □□ . S . □□ . PG . □□ / □□

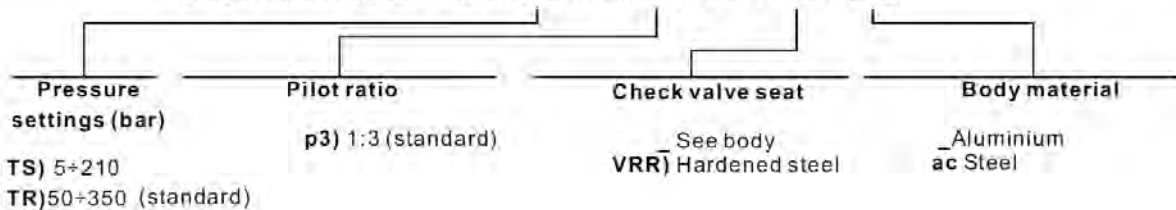

• DIMENSIONS (mm)

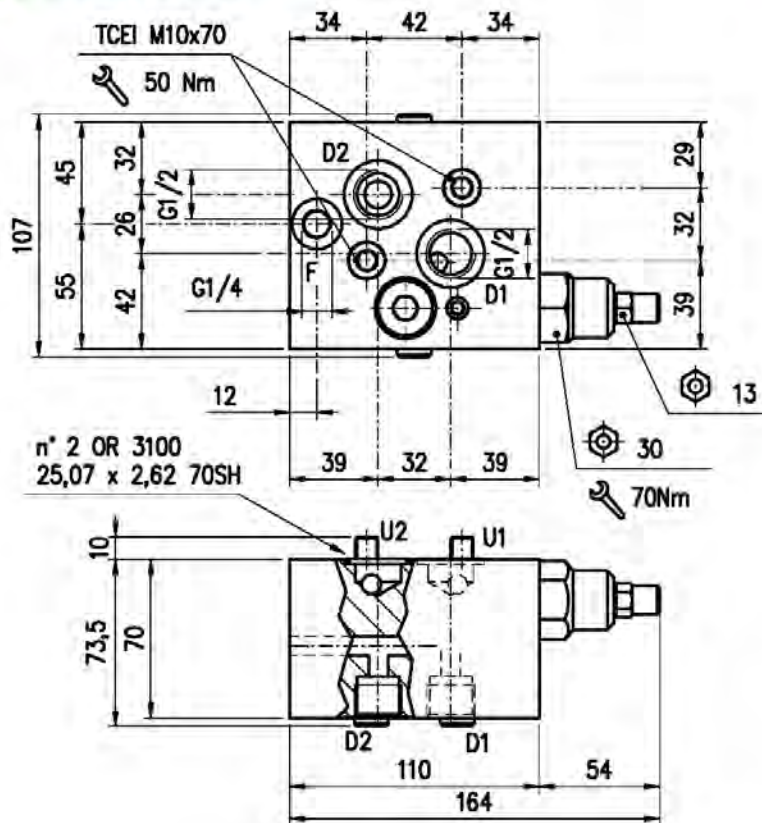

• HYDRAULIC DIAGRAM

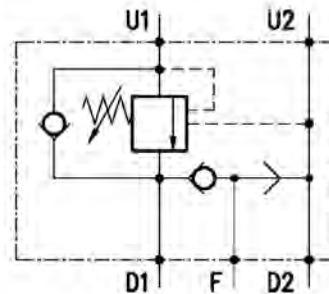

• ASSEMBLY DIAGRAM

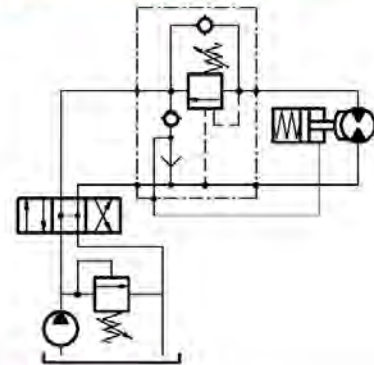

• DESCRIPTION

Single overcenter valves, face mounting for Sauer Danfoss motor OMS series with connection gate for hydraulic brake release.

• OPERATION

The oil flow is allowed from D1 to U1 and is stopped in the opposite way (from U1 to D1) up to the spring setting value. Free oil flow from U1 to D1 is strictly possible when the pilot pressure in D2 and U2 is strong enough to pilot the valve poppet.

Use the following formula to assert the applicable pilot pressure:

$$(\text{valve setting} - \text{load pressure}) \div \text{pilot ratio} = \text{pilot pressure}$$

For example:

If your pilot ratio is 1:3, your setting pressure is 250 bar and your load pressure is 130 bar then you will need 30 bar pilot pressure in order to displace the load. $[(250 \text{ bar} - 130 \text{ bar}) \div 3 = 40 \text{ bar}]$.

Should counterpressure arise in D1, the setting value of valve poppet (1:1 ratio) will increase and the pilot pressure be negatively affected (1:1 ratio).

The special shuttle valve allows releasing of the hydraulic parking brakes.

• PERFORMANCE

Maximum flow: 70 l/min

Maximum Pressure:

- Aluminium body: 210 bar

- Steel body: 350 bar

Application range with standard springs:

- 5 - 210 bar pressure increase = 36 bar/turn (test setting: 170 bar at 5 l/min)

- 50 - 350 bar pressure increase = 90 bar/turn (test setting: 280 bar at 5 l/min) STANDARD

Oil leaks from U1 to D1: 0,25 cc/minute (5 drops) at 210 bar and 80% of the spring setting value with oil viscosity of 46 cSt

• CROSS SECTION

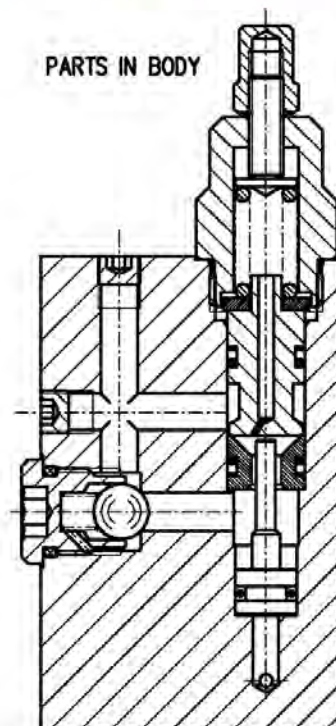

**OVERCENTER VALVES (SAUER-DANFOSS MOTOR)
VOSL/SC/F/A 12/OMS**

Pilot ratio:

- 1:3 (standard type)
- 1:7 (on request only)

Working temperature:

- Minimum -25°C max 90°C with standard BUNANGaskets
- Minimum -20°C max 120°C with optional VITONGaskets

Spare parts KIT:

Screws and Seals (Ordering code: 5KTM0OMS03)

• **RECOMMANDATIONS**

Fluid: best use mineral oil with viscosity ranging between 10 and 200 cSt

Filter: see General Informations.

Weight:

- aluminium valves 2.25 kg
- steel valves 5.3 kg

Material: made out of high-grade steel duly treated and fabricated.

For more information please ask our Technical Department.

Variations and modifications of technical features and dimensions are reserved. HANSA-TMP s.r.l. also reserves the right to stop production of each and any model listed in the catalogue with no notice.

Copyrights on the text contained herein belong to HANSA-TMP s.r.l.. Partial and full reproductions or copies of this catalogue are forbidden.

• **RATING DIAGRAMS**

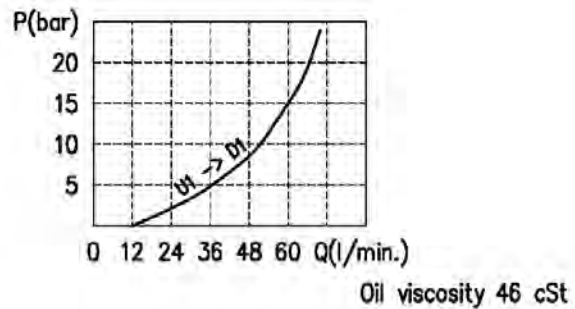
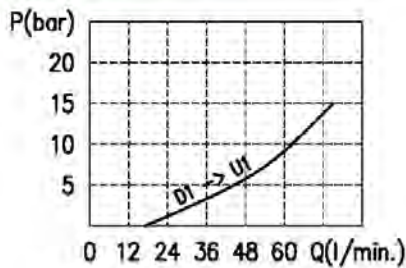

• **CODE NUMBER**

VOSL / SC / F / A 12 / OMS / □□ . S . □□ . PG . □□ / □□

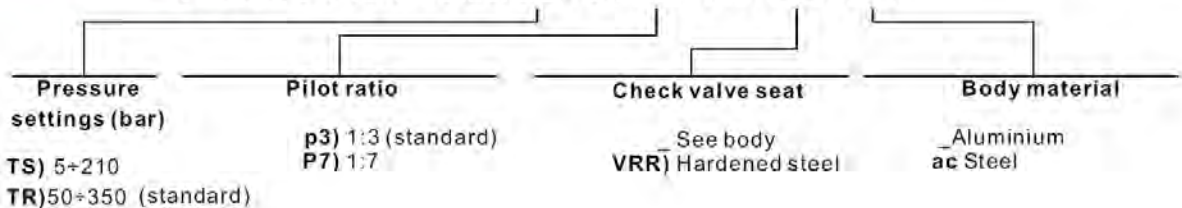

• DIMENSIONS (mm)

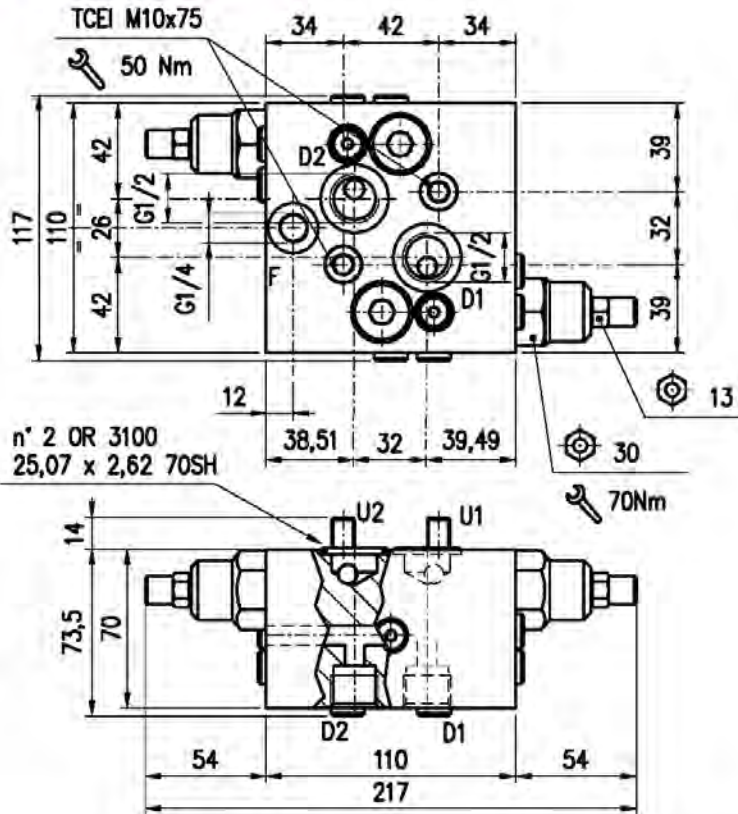

• HYDRAULIC DIAGRAM

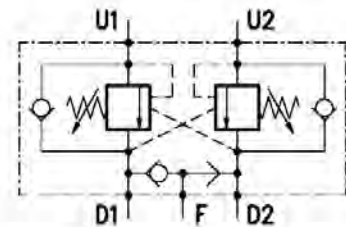

• ASSEMBLY DIAGRAM

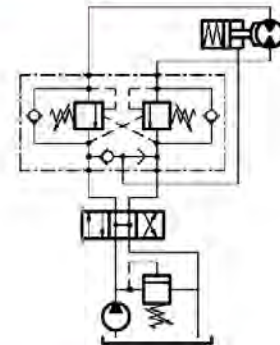

• DESCRIPTION

Dual overcenter valves, face mounting for Sauer Danfoss motor OMS series with connection gate for hydraulic brake release.

• OPERATION

The oil flow is allowed from D1 (D2) to U1 (U2) and is stopped in the opposite way from U1 (U2) to D1 (D2) up to the spring setting value. Free oil flow from U1 (U2) to D1 (D2) is strictly possible when the pilot pressure in D2 and U2 (D1 and U1) is strong enough to pilot the valve poppet.

Use the following formula to assert the applicable pilot pressure:

$$(\text{valve setting} - \text{load pressure}) \div \text{pilot ratio} = \text{pilot pressure}$$

For example:

If your pilot ratio is 1:3, your setting pressure is 250 bar and your load pressure is 130 bar then you will need 30 bar pilot pressure in order to displace the load. $[(250 \text{ bar} - 130 \text{ bar}) \div 3 = 40 \text{ bar}]$.

Should counterpressure arise in D1 (D2), the setting value of valve poppet (1:1 ratio) will increase and the pilot pressure be negatively affected (1:1 ratio).

The special shuttle valve allows releasing of the hydraulic parking brakes.

• PERFORMANCE

Maximum flow: 70 l/min

Maximum Pressure:

- Aluminium body: 210 bar

- Steel body: 350 bar

Application range with standard springs:

- 5 - 210 bar pressure increase = 36 bar/turn (test setting: 170 bar at 5 l/min)

- 50 - 350 bar pressure increase = 90 bar/turn (test setting: 280 bar at 5 l/min) STANDARD

Oil leaks from U1 (U2) to D1 (D2): 0.25 cc/minute (5 drops) at 210 bar and 80% of the spring setting value with oil viscosity of 46 cSt

• CROSS SECTION

PARTS IN BODY

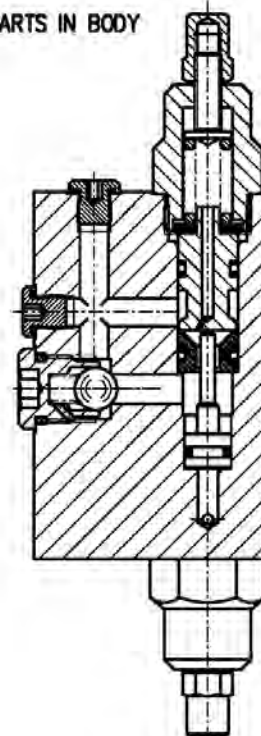

**OVERCENTER VALVES (SAUER-DANFOSS MOTOR)
VODL/SC/F/A 12/OMS**

Pilot ratio:

- 1:3 (standard type)
- 1:7 (on request only)

Working temperature:

- Minimum -25°C max 90°C with standard BUNANGaskets
- Minimum -20°C max 120°C with optional VITONGaskets

Spare parts KIT:

Screws and Seals (Ordering code: 5KTM00MS05)

• **RECOMMANDATIONS**

Fluid: best use mineral oil with viscosity ranging between 10 and 200 cSt

Filter: see General Informations.

Weight:

- aluminium valves 2.7 kg
- steel valves 5.7 kg

Material: made out of high-grade steel duly treated and fabricated.

For more information please ask our Technical Department.

Variations and modifications of technical features and dimensions are reserved. HANSA-TMP s.r.l. also reserves the right to stop production of each and any model listed in the catalogue with no notice.

Copyrights on the text contained herein belong to HANSA-TMP s.r.l.. Partial and full reproductions or copies of this catalogue are forbidden.

• **RATING DIAGRAMS**

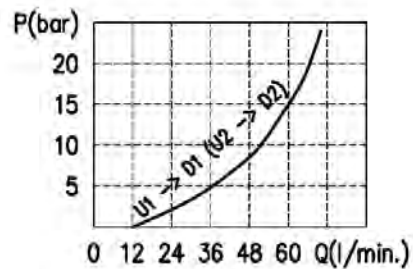
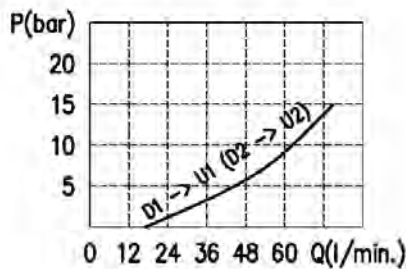

Oil viscosity 46 cSt

• **CODE NUMBER**

VODL / SC / F / A 12 / OMS / □□ . S . □□ . PG . □□ / □□

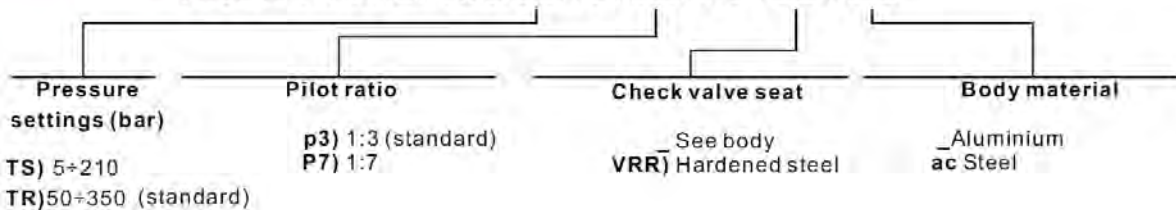

• DIMENSIONS (mm)

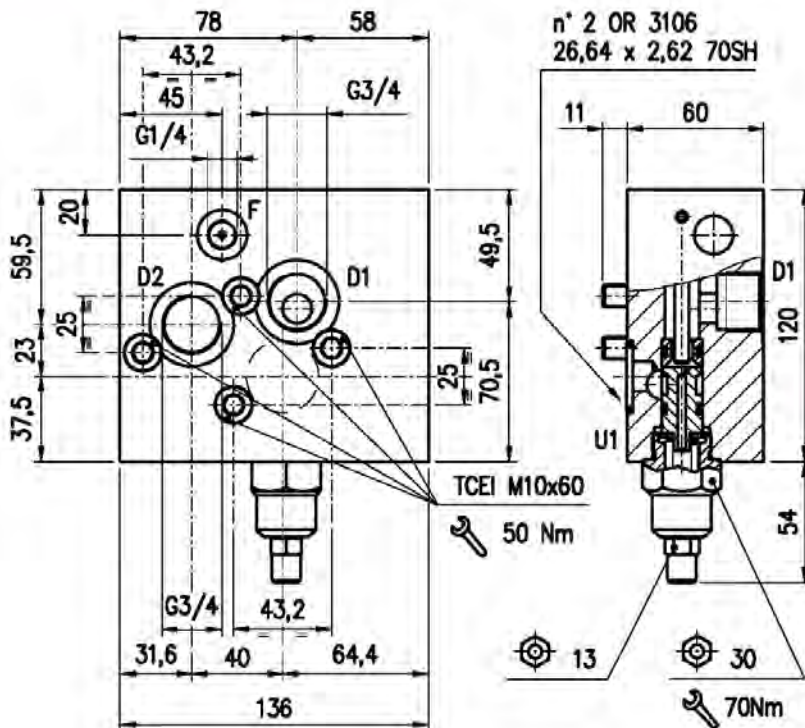

• HYDRAULIC DIAGRAM

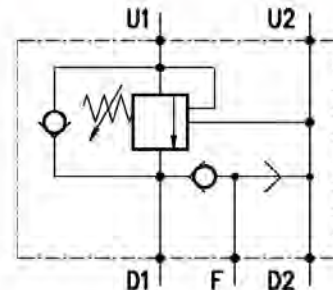

• ASSEMBLY DIAGRAM

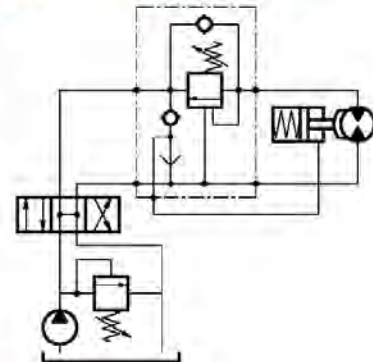

• DESCRIPTION

Dual overcenter valves, face mounting for Sauer Danfoss motor OMT series with connection gate for hydraulic brake release.

• OPERATION

The oil flow is allowed from D1 (D2) to U1 (U2) and is stopped in the opposite way from U1 (U2) to D1 (D2) up to the spring setting value. Free oil flow from U1 (U2) to D1 (D2) is strictly possible when the pilot pressure in D2 and U2 (D1 and U1) is strong enough to pilot the valve poppet.

Use the following formula to assert the applicable pilot pressure:

$$(\text{valve setting} - \text{load pressure}) \div \text{pilot ratio} = \text{pilot pressure}$$

For example:

If your pilot ratio is 1:3, your setting pressure is 250 bar and your load pressure is 130 bar then you will need 30 bar pilot pressure in order to displace the load. $[(250 \text{ bar} - 130 \text{ bar}) \div 3 = 40 \text{ bar}]$

Should counterpressure arise in D1 (D2), the setting value of valve poppet (1:1 ratio) will increase and the pilot pressure be negatively affected (1:1 ratio).

The special shuttle valve allows releasing of the hydraulic parking brakes.

• PERFORMANCE

Maximum flow: 120 l/min

Maximum Pressure:

- Aluminium body: 210 bar

- Steel body: 350 bar

Application range with standard springs:

- 5 - 210 bar pressure increase = 36 bar/turn (test setting: 170 bar at 5 l/min)

- 50 - 350 bar pressure increase = 90 bar/turn (test setting: 280 bar at 5 l/min) STANDARD

Oil leaks from U1 (U2) to D1 (D2): 0.25 cc/minute (5 drops) at 210 bar and 80% of the spring setting value with oil viscosity of 46 cSt

• CROSS SECTION

PARTS IN BODY

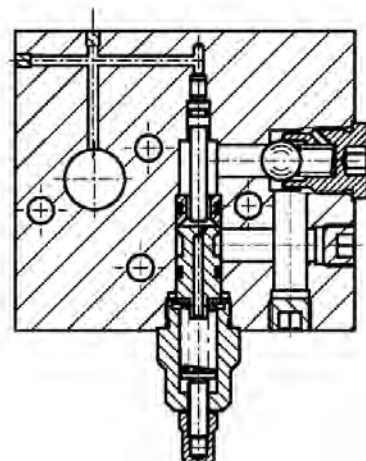

**OVERCENTER VALVES (SAUER-DANFOSS MOTOR)
VOSL/SC/F/A 34/OMT**

Pilot ratio:

- 1:3 (standard type)
- 1:7 (on request only)

Working temperature:

- Minimum -25°C max 90°C with standard BUNANGaskets
- Minimum -20°C max 120°C with optional VITONGaskets

Spare parts KIT:

Screws and Seals (Ordering code: 5KTM00MT02)

• **RECOMMANDATIONS**

Fluid: best use mineral oil with viscosity ranging between 10 and 200 cSt

Filter: see General Informations.

Weight:

- aluminium valves 4.5 kg
- steel valves 9.5 kg

Material: made out of high-grade steel duly treated and fabricated.

For more information please ask our Technical Department.

Variations and modifications of technical features and dimensions are reserved. HANSA-TMP s.r.l. also reserves the right to stop production of each and any model listed in the catalogue with no notice.

Copyrights on the text contained herein belong to HANSA-TMP s.r.l.. Partial and full reproductions or copies of this catalogue are forbidden.

• **RATING DIAGRAMS**

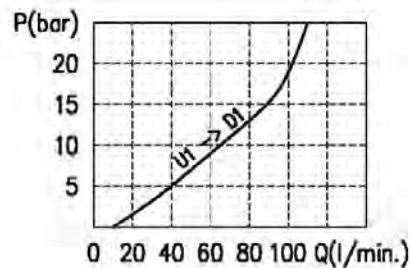
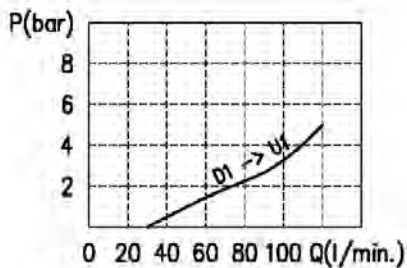

Oil viscosity 46 cSt

• **CODE NUMBER**

VOSL / SC / F / A 34 / OMT / □□ . S . □□ . PG . □□ / □□

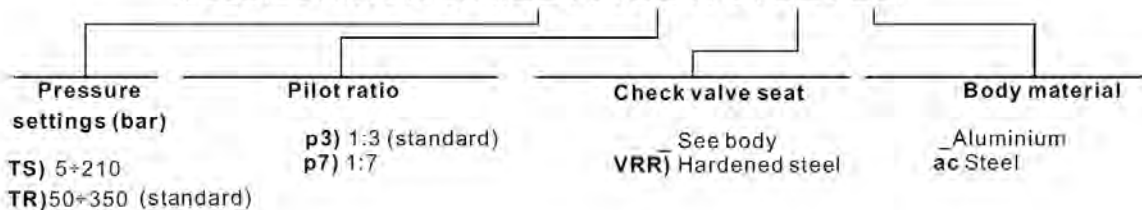

• DIMENSIONS (mm)

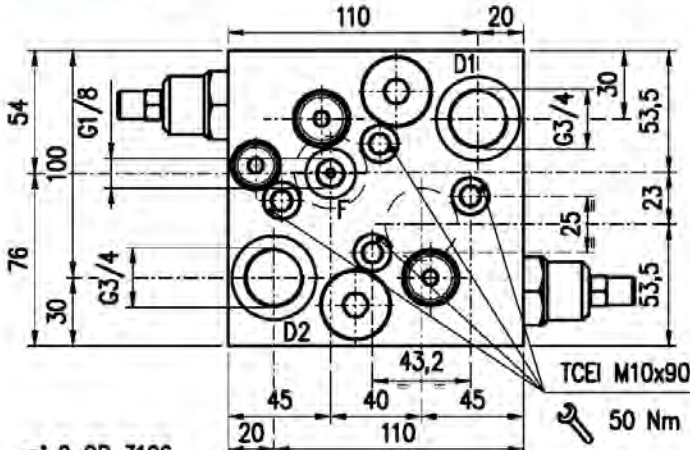

n° 2 OR 3106
26,64 x 2,62 70SH

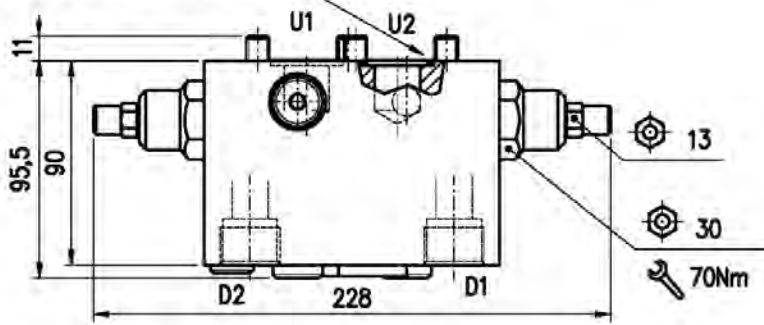

• HYDRAULIC DIAGRAM

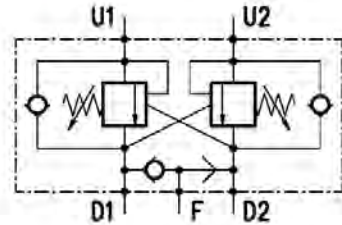

• ASSEMBLY DIAGRAM

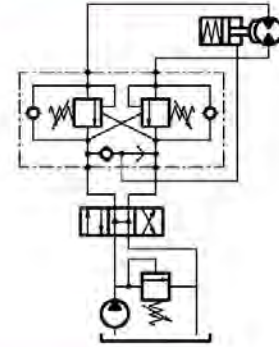

• DESCRIPTION

Dual overcenter valves, face mounting for Sauer Danfoss motor OMT series with connection gate for hydraulic brake release.

• OPERATION

The oil flow is allowed from D1 (D2) to U1 (U2) and is stopped in the opposite way from U1 (U2) to D1 (D2) up to the spring setting value. Free oil flow from U1 (U2) to D1 (D2) is strictly possible when the pilot pressure in D2 and U2 (D1 and U1) is strong enough to pilot the valve poppet.

Use the following formula to assert the applicable pilot pressure:

$$(\text{valve setting} - \text{load pressure}) \div \text{pilot ratio} = \text{pilot pressure}$$

For example:

If your pilot ratio is 1:3, your setting pressure is 250 bar and your load pressure is 130 bar then you will need 30 bar pilot pressure in order to displace the load. $[(250 \text{ bar} - 130 \text{ bar}) \div 3 = 40 \text{ bar}]$.

Should counterpressure arise in D1 (D2), the setting value of valve poppet (1:1 ratio) will increase and the pilot pressure be negatively affected (1:1 ratio).

The special shuttle valve allows releasing of the hydraulic parking brakes.

• PERFORMANCE

Maximum flow: 120 l/min

Maximum Pressure:

- Aluminium body: 210 bar
- Steel body: 350 bar

Application range with standard springs:

- 5 - 210 bar pressure increase= 36 bar/turn (test setting: 170 bar at 5 l/min)
- 50 - 350 bar pressure increase= 90 bar/turn (test setting: 280 bar at 5 l/min) STANDARD

Oil leaks from U1 (U2) to D1 (D2): 0.25 cc/minute (5 drops) at 210 bar and 80% of the spring setting value with oil viscosity of 46 cSt

• CROSS SECTION

PARTS IN BODY

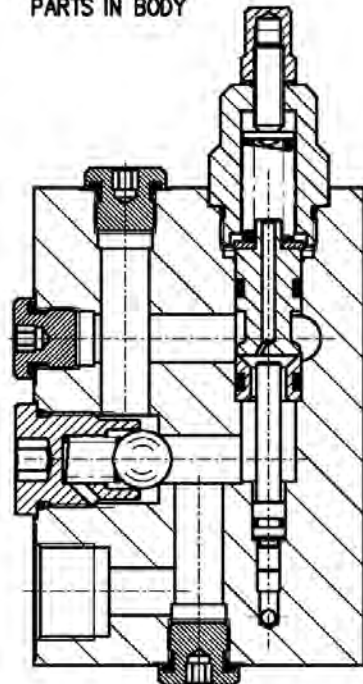

**OVERCENTER VALVES (SAUER-DANFOSS MOTOR)
VODL/SC/F/A 34/OMT**

Pilot ratio:

- 1:3 (standard type)
- 1:7 (on request only)

Working temperature:

- Minimum -25°C max 90°C with standard BUNAN gaskets
- Minimum -20°C max 120°C with optional VITON gaskets

Spare parts KIT:

Screws and Seals (Ordering code: 5KTM00MT03)

• **RECOMMANDATIONS**

Fluid: best use mineral oil with viscosity ranging between 10 and 200 cSt

Filter: see General Informations.

Weight:

- aluminium valves 4.5 kg
- steel valves 9.5 kg

Material: made out of high-grade steel duly treated and fabricated.

For more information please ask our Technical Department.

Variations and modifications of technical features and dimensions are reserved. HANSA-TMP s.r.l. also reserves the right to stop production of each and any model listed in the catalogue with no notice.

Copyrights on the text contained herein belong to HANSA-TMP s.r.l.. Partial and full reproductions or copies of this catalogue are forbidden.

• **RATING DIAGRAMS**

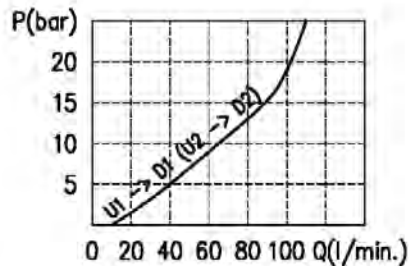
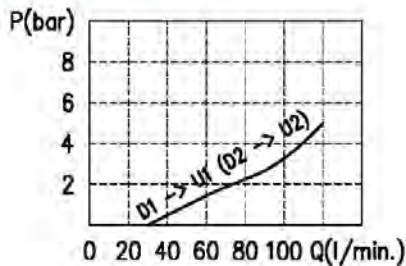

Oil viscosity 46 cSt

• **CODE NUMBER**

VODL / SC / F/A 34 / OMT/□□ . S . □□ . PG . □□ / □□

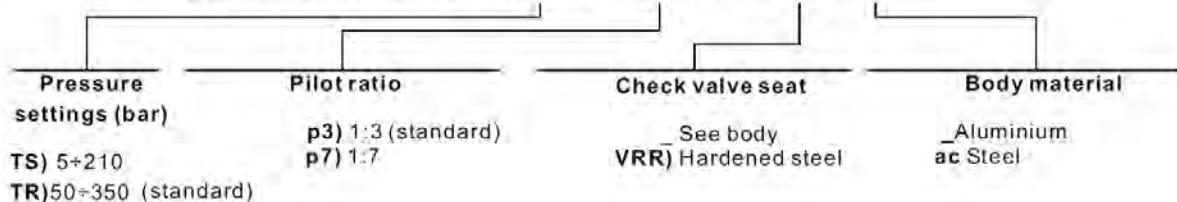

• DIMENSIONS (mm)

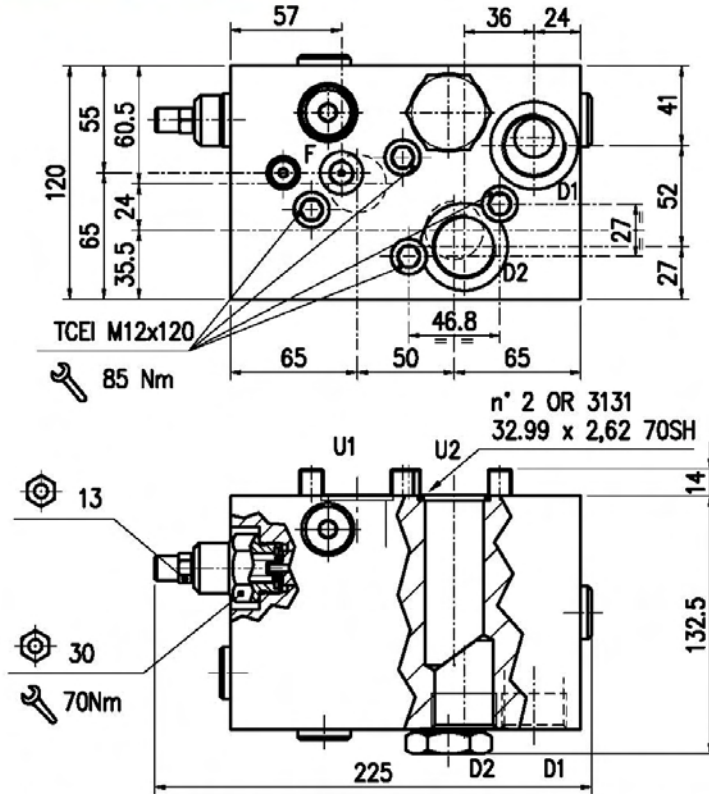

PORTS CONNECTIONS: D1, D2 = G 1"; F = G 1/4

• HYDRAULIC DIAGRAM

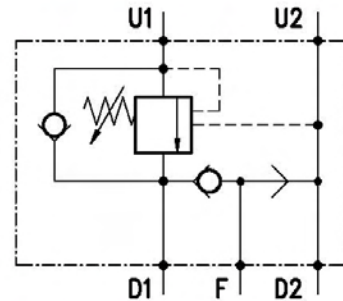

• ASSEMBLY DIAGRAM

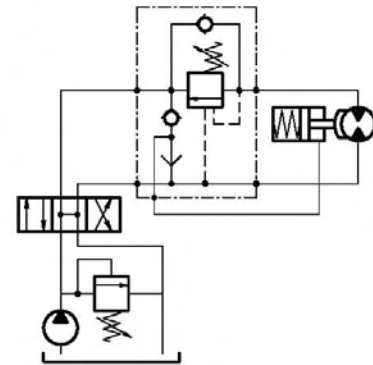

• DESCRIPTION

Dual overcenter valves, face mounting for Sauer Danfoss motor OMV series with connection gate for hydraulic brake release, including OR and Screws.

• OPERATION

The oil flow is allowed from D1 (D2) to U1 (U2) and is stopped in the opposite way from U1 (U2) to D1 (D2) up to the spring setting value. Free oil flow from U1 (U2) to D1 (D2) is strictly possible when the pilot pressure in D2 and U2 (D1 and U1) is strong enough to pilot the valve poppet.

Use the following formula to assert the applicable pilot pressure:

$$(\text{valve setting} - \text{load pressure}) \div \text{pilot ratio} = \text{pilot pressure}$$

For example:

If your pilot ratio is 1:3, your setting pressure is 250 bar and your load pressure is 130 bar then you will need 30 bar pilot pressure in order to displace the load. $[(250 \text{ bar} - 130 \text{ bar}) \div 3 = 40 \text{ bar}]$.

Should counterpressure arise in D1 (D2), the setting value of valve poppet (1:1 ratio) will increase and the pilot pressure be negatively affected (1:1 ratio).

The special shuttle valve allows releasing of the hydraulic parking brakes.

• PERFORMANCE

Maximum flow: 180 l/min

Maximum Pressure:

- Aluminium body: 210 bar
- Steel body: 350 bar

Application range with standard springs:

- 5 - 210 bar, pressure increase= 45 bar/turn (test setting: 170 bar at 5 l/min)
- 50 - 350 bar, pressure increase= 96 bar/turn (test setting: 280 bar at 5 l/min) STANDARD

Oil leaks from U1 (U2) to D1 (D2): 0.25 cc/minute (5 drops) at 210 bar and 80% of the spring setting value with oil viscosity of 46 cSt

• CROSS SECTION

PARTS IN BODY

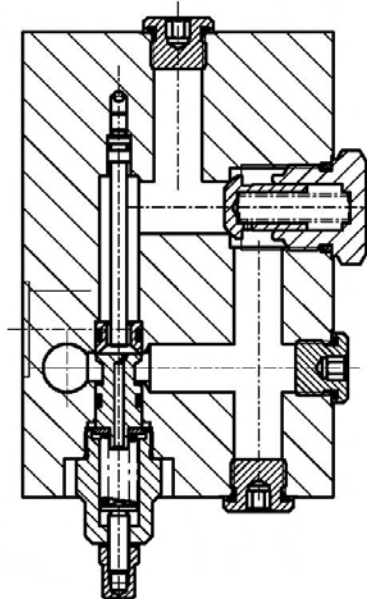

Pilot ratio:

- 1:3 (standard type)
- 1:7 (on request only)

Working temperature:

- Minimum -25°C max 90°C with standard BUNANGaskets
- Minimum -20°C max 120°C with optional VITONGaskets

Spare parts KIT:

Screws and Seals (Ordering code: 5KTM00MV01)

• **RECOMMENDATIONS**

Fluid: best use mineral oil with viscosity ranging between 10 and 200 cSt

Filter: see General Informations.

Weight:

- aluminium valves 9 kg
- steel valves 17,5 kg

Material: made out of high-grade steel duly treated and fabricated.

For more information please ask our Technical Department.

Variations and modifications of technical features and dimensions are reserved. HANSA-TMP s.r.l. also reserves the right to stop production of each and any model listed in the catalogue with no notice.

Copyrights on the text contained herein belong to HANSA-TMP s.r.l.. Partial and full reproductions or copies of this catalogue are forbidden.

• **RATING DIAGRAMS**

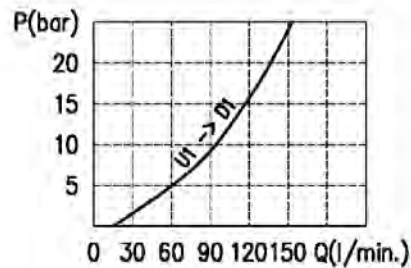
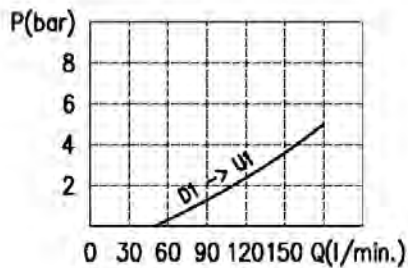

Oil viscosity 46 cSt

• **CODE NUMBER**

VOSL / SC / F / A 100 / OMV / □□ . S . □□ . PG . □□ / □□

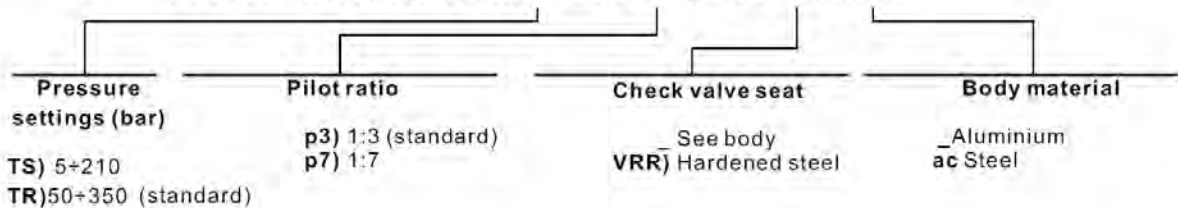

• DIMENSIONS (mm)

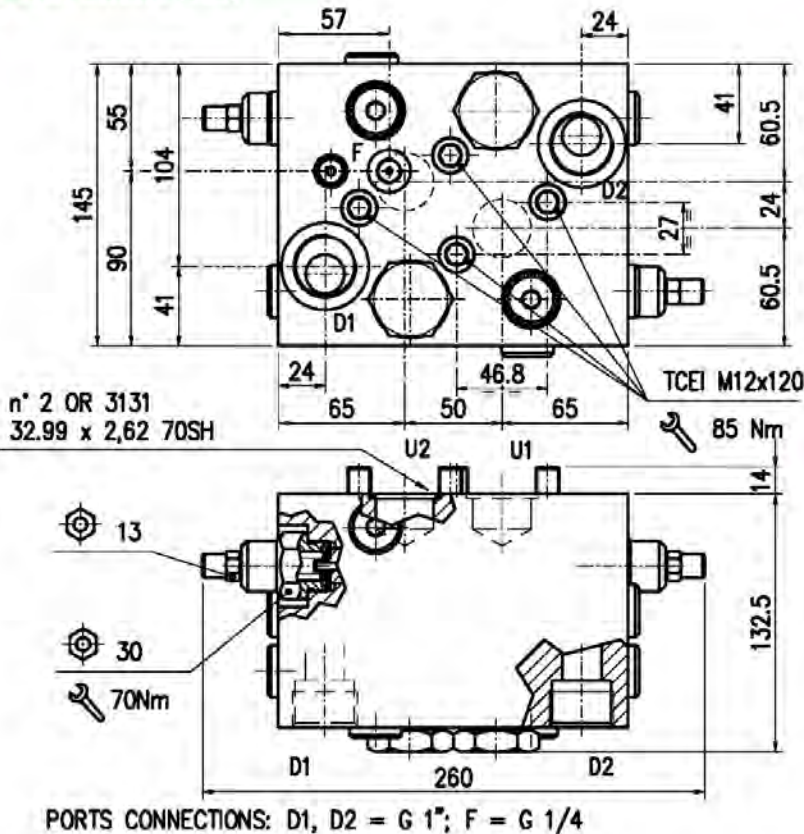

• HYDRAULIC DIAGRAM

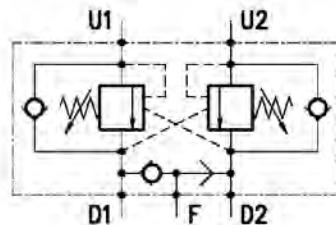

• ASSEMBLY DIAGRAM

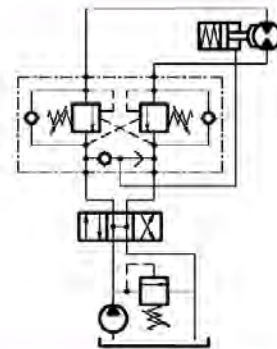

• DESCRIPTION

Dual overcenter valves, face mounting for Sauer Danfoss motor OMV series with connection gate for hydraulic brake release, including OR and Screws.

• OPERATION

The oil flow is allowed from D1 (D2) to U1 (U2) and is stopped in the opposite way from U1 (U2) to D1 (D2) up to the spring setting value. Free oil flow from U1 (U2) to D1 (D2) is strictly possible when the pilot pressure in D2 and U2 (D1 and U1) is strong enough to pilot the valve poppet.

Use the following formula to assert the applicable pilot pressure:

$$(\text{valve setting} - \text{load pressure}) \div \text{pilot ratio} = \text{pilot pressure}$$

For example:

If your pilot ratio is 1:3, your setting pressure is 250 bar and your load pressure is 130 bar then you will need 30 bar pilot pressure in order to displace the load. $[(250 \text{ bar} - 130 \text{ bar}) \div 3 = 40 \text{ bar}]$.

Should counterpressure arise in D1 (D2), the setting value of valve poppet (1:1 ratio) will increase and the pilot pressure be negatively affected (1:1 ratio).

The special shuttle valve allows releasing of the hydraulic parking brakes.

• PERFORMANCE

Maximum flow: 180 l/min

Maximum Pressure:

- Aluminium body: 210 bar

- Steel body: 350 bar

Application range with standard springs:

- 5 - 210 bar, pressure increase= 45 bar/turn (test setting: 170 bar at 5 l/min)

- 50 - 350 bar, pressure increase= 96 bar/turn (test setting: 280 bar at 5 l/min) STANDARD

Oil leaks from U1 (U2) to D1 (D2): 0.25 cc/minute (5 drops) at 210 bar and 80% of the spring setting value with oil viscosity of 46 cSt

• CROSS SECTION

PARTS IN BODY

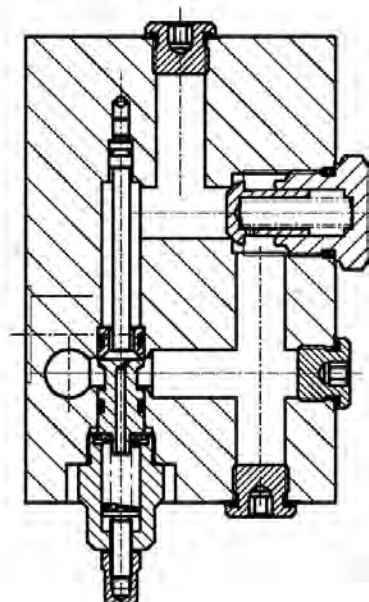

Pilot ratio:

- 1:3 (standard type)
- 1:7 (on request only)

Working temperature:

- Minimum -25°C max 90°C with standard BUNANgaskets
- Minimum -20°C max 120°C with optional VITONgaskets

Spare parts KIT:

Screws and Seals (Ordering code: 5KTM00MV01)

• **RECOMMANDATIONS**

Fluid: best use mineral oil with viscosity ranging between 10 and 200 cSt

Filter: see General Informations.

Weight:

- aluminium valves 9 kg
- steel valves 17,5 kg

Material: made out of high-grade steel duly treated and fabricated.

For more information please ask our Technical Department.

Variations and modifications of technical features and dimensions are reserved. **HANSA-TMP s.r.l.** also reserves the right to stop production of each and any model listed in the catalogue with no notice.

Copyrights on the text contained herein belong to **HANSA-TMP s.r.l.**. Partial and full reproductions or copies of this catalogue are forbidden.

• **RATING DIAGRAMS**

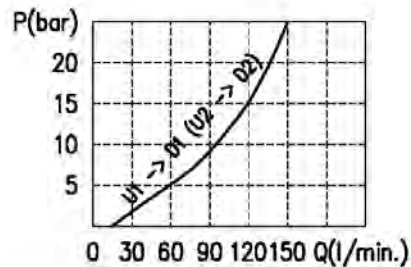
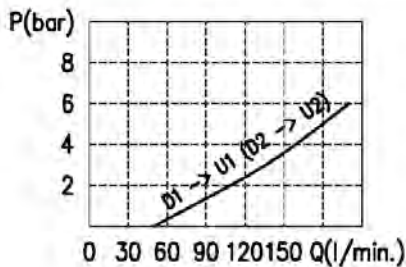

Oil viscosity 46 cSt

• **CODE NUMBER**

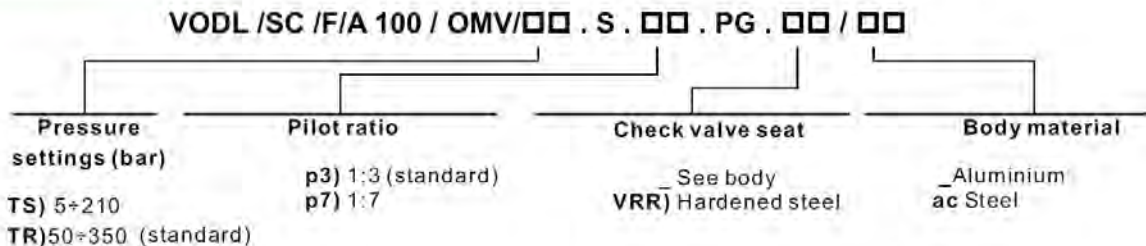

• DIMENSIONS (mm)

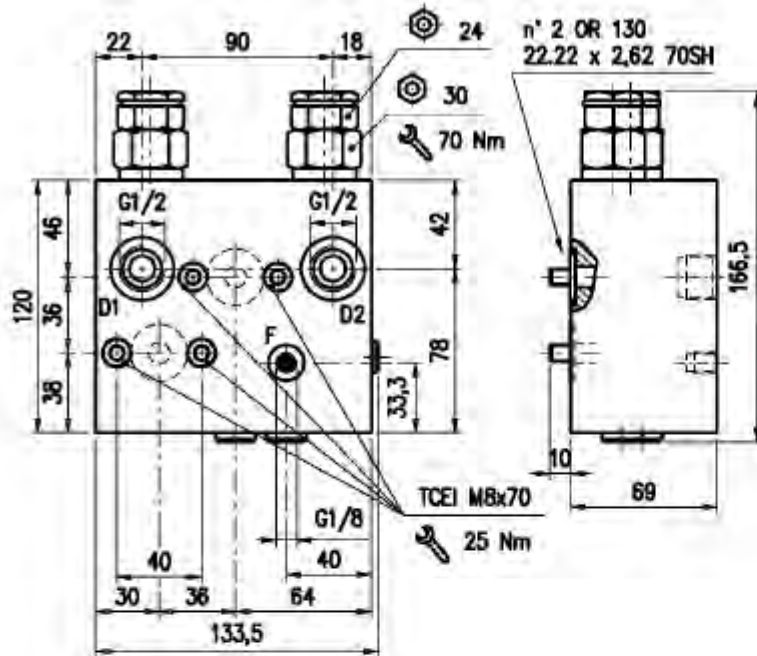

• HYDRAULIC DIAGRAM

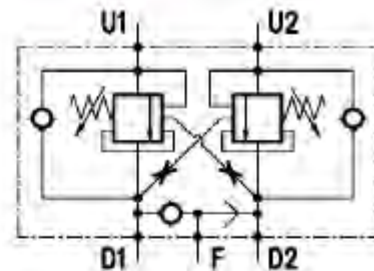

• ASSEMBLY DIAGRAM

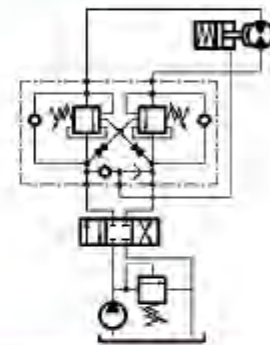

• DESCRIPTION

Dual overcenter valves for closed centre, face mounting for Sauer-Danfoss motor OMR Series, including OR and Screws.

• OPERATION

The oil flow is allowed from D1 (D2) to U1 (U2) and is stopped in the opposite way, from U1 (U2) to D1 (D2) up to the spring setting value. Free oil flow from U1 (U2) to D1 (D2) is strictly possible when the pilot pressure in D2 and U2 (D1 and U1) is strong enough to pilot the valve poppet.

Use the following formula to assert the applicable pilot pressure:

(valve setting – load pressure) ÷ pilot ratio = pilot pressure

For example:

If your pilot ratio is 1:4, your setting pressure is 250 bar and your load pressure is 130 bar then you will need 30 bar pilot pressure in order to displace the load. $[(250 \text{ bar} - 130 \text{ bar}) \div 4 = 30 \text{ bar}]$

Should counterpressure arise in D1 (D2), the pilot pressure (1:1 ratio) be negatively affected.

• PERFORMANCE

Maximum flow: 90 l/min

Maximum Pressure:

- Aluminium body: 210 bar

- Steel body: 350 bar

Application range with standard springs:

- 50-220 bar, pressure increase = 36.7 bar/tum; (test setting: 180 bar at 5 l/min) STANDARD

- 180-350 bar, pressure increase = 76.9 bar/tum; (test setting: 250 bar at 5 l/min)

Oil leaks from U1 (U2) to D1 (D2): 0.25 cc/minute (5 drops) at 210 bar and 80% of the spring setting value with oil viscosity of 46 cSt.

• CROSS SECTION

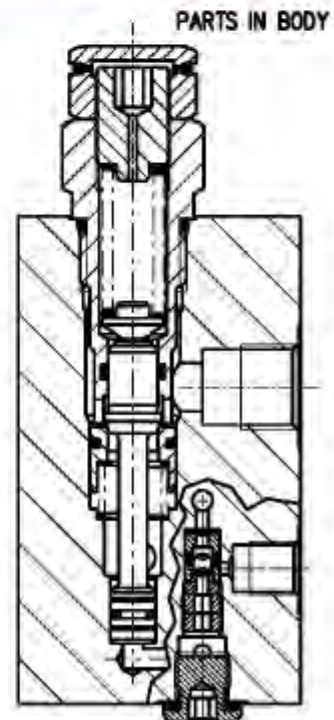

Pilot ratio: 1:4

Working temperature:

- Minimum -25°C max 90°C with standard BUNAN gaskets

- Minimum -20°C max 120°C with optional VITON gaskets

Spare parts KIT:

Screws and Seals (Ordering code: 5KTM00MR04)

• RECOMMANDATIONS

Fluid: best use mineral oil with viscosity ranging between 10 and 200 cSt

Filter: see General Informations.

Weight:

- aluminium body 3 kg

- steel body 5,9 kg

Material: made out of high-grade steel duly treated and fabricated.

For more information please ask our Technical Department.

Variations and modifications of technical features and dimensions are reserved. HANSA-TMP s.r.l. also reserves the right to stop production of each and any model listed in the catalogue with no notice.

Copyrights on the text contained herein belong to HANSA-TMP s.r.l.. Partial and full reproductions or copies of this catalogue are forbidden.

• CODE NUMBER

VODL / SC / CC / F / A 12 / OMR / CC 16 / □□ .p4 / □□

Pressure settings (bar)

TS) 50÷220
TR) 180÷350

Body material

_Aluminium
ac Steel

MOTION CONTROL VALVES INDEX

Description	type	code	page
Cross line valve with anti cav. ,anti shock	VABAL / SC / F 12 / OMR	A.16H0.200	104
Cross line valve with anti cav. ,anti shock	VABAL / SC / F 12 / OMS	A.16H0.300	106
Cross line valve with anti cav. ,anti shock	VABAL / SC / F 34 / OMT	A.16H0.400	108
Cross line valve with anti cav. ,anti shock	VABAL / SC / F 100 / OMV	A.16H0. 500	110
Cross line valve with anti cav. ,anti shock	VABAL / SC / F / A 12 / OMR	A.16H5.200	112
Cross line valve with anti cav. ,anti shock	VABAL / SC / F / A 12 / OMS	A.16H5.300	114
Cross line valve with anti cav. ,anti shock	VABAL / SC / F / A 34 / OMT	A.16H5.400	116

• DIMENSIONS (mm)

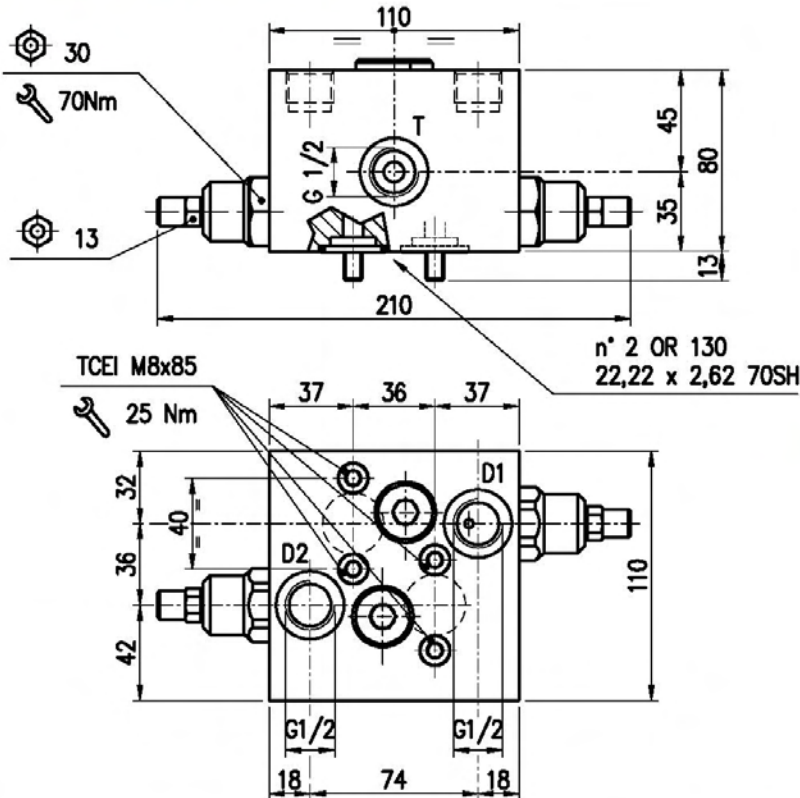

• HYDRAULIC DIAGRAM

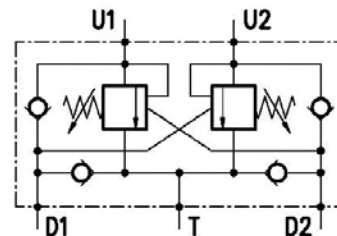

• ASSEMBLY DIAGRAM

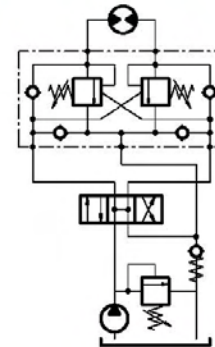

• DESCRIPTION

Cross-line, relief valves for motion control, anti-shock and anti-cavitation, face mounting for Sauer-Danfoss motor OMR Series including OR and Screws.

• OPERATION

The oil flow is allowed from D1 (D2) to U1 (U2) and is stopped in the opposite way from U1 (U2) to D1 (D2) up to the spring setting value. Free oil flow from U1 (U2) to D1 (D2) is strictly possible when the pilot pressure in D2 and U2 (D1 and U1) is strong enough to pilot the valve poppet.

Use the following formula to assert the applicable pilot pressure:

$$(\text{valve setting} - \text{load pressure}) \div \text{pilot ratio} = \text{pilot pressure}$$

For example:

If your pilot ratio is 1:4, your setting pressure is 250 bar and your load pressure is 130 bar then you will need 30 bar pilot pressure in order to displace the load. $[(250 \text{ bar} - 130 \text{ bar}) \div 4 = 30 \text{ bar}]$.

Counterpressure in D1 (D2) increase the setting value (1:1 ratio) of the poppet spring and negatively affect the pilot pressure (1:1 ratio).

Use of two check-valves between D1 (D2) and T avoids cavitation on the pressure line during relief operation.

• PERFORMANCE

Maximum flow: 40 l/min

Maximum Pressure:

- aluminium body 210 bar
- steel body 350 bar

Application range with standard springs:

- 5 - 210 bar, pressure increase= 26 bar/turn (test setting: 170 bar at 5 l/min)
- 50 - 350 bar, pressure increase= 87 bar/turn (test setting: 280 bar at 5 l/min)

Oil leaks from U1 (U2) to D1 (D2): 0,25 cc/minute (5 drops) at 210 bar and 80% of the spring setting value with oil viscosity of 46 cSt.

• CROSS SECTION

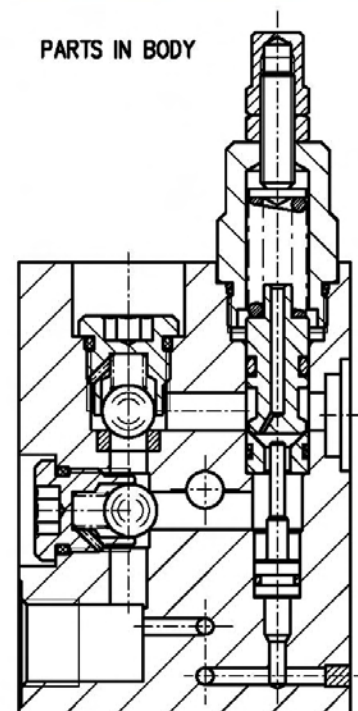

Pilot ratio: 1:4

Working temperature:

- minimum -25°C max 90°C with standard BUNA N gaskets
- minimum -20°C max 120°C with optional VITON gaskets

Spare parts KIT:

screws and seals (Ordering code: 5KTM00MR05)

• RECOMMANDATIONS

Fluid: best use mineral oil with viscosity ranging between 10 and 200 cSt

Filter: see General Informations.

Weight:

- aluminium body: 3.1 kg
- steel body: 6 kg

Material: internal components made out of high-grade steel duly treated and fabricated.

For more information please ask our Technical Department.

Variations and modifications of technical features and dimensions are reserved. HANSA-TMP s.r.l. also reserves the right to stop production of each and any model listed in the catalogue with no notice.

Copyrights on the text contained herein belong to HANSA-TMP s.r.l.. Partial and full reproductions or copies of this catalogue are forbidden.

• RATING DIAGRAMS

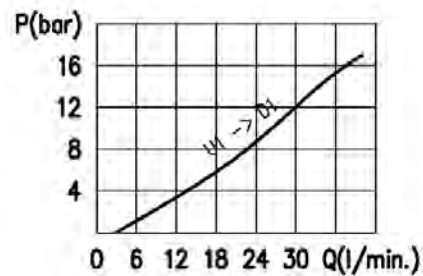
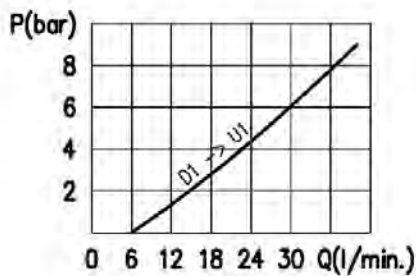

Oil viscosity 46 cSt

• CODE NUMBER

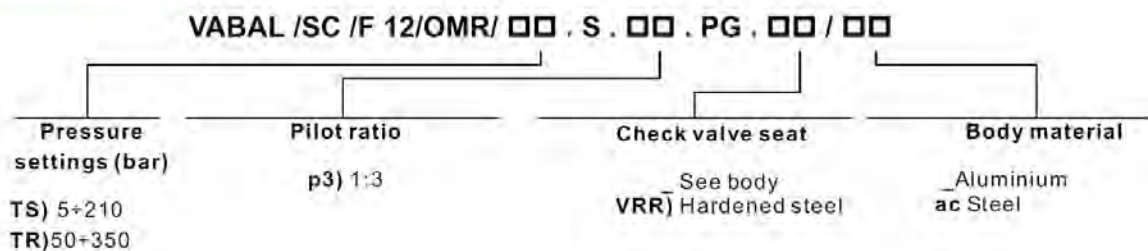

• DIMENSIONS (mm)

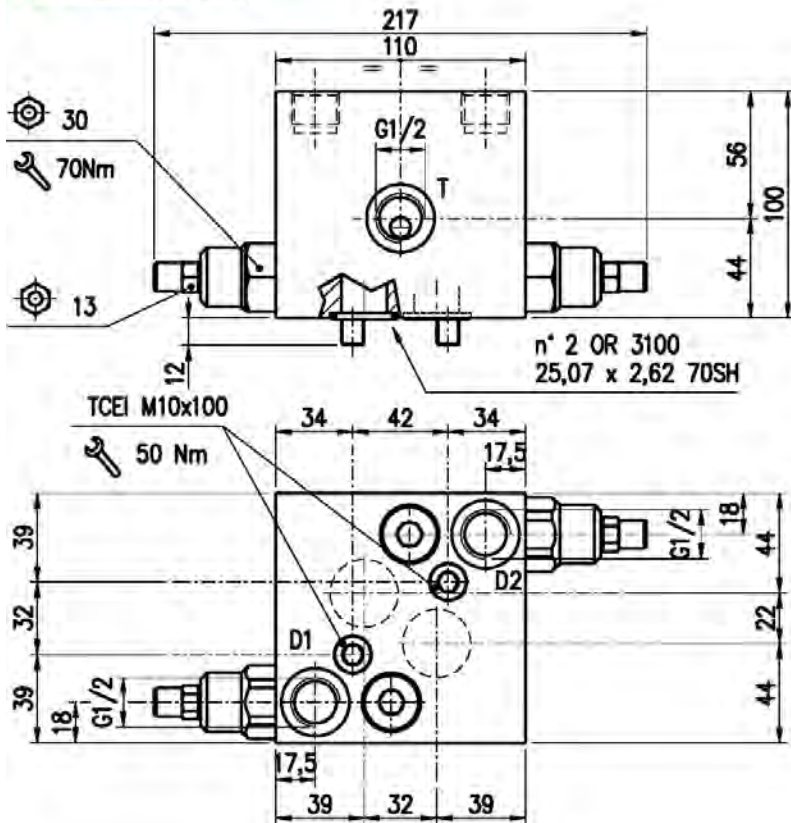

• HYDRAULIC DIAGRAM

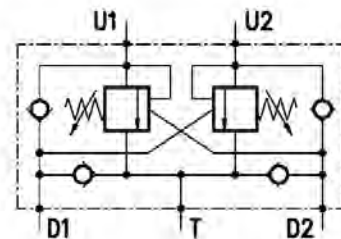

• ASSEMBLY DIAGRAM

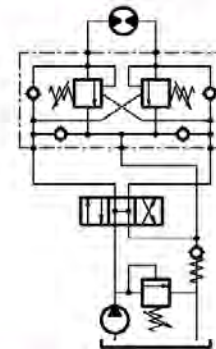

• DESCRIPTION

Cross-line, relief valves for motion control, anti-shock and anti-cavitation, face mounting for Sauer-Danfoss motor OMS Series including OR and Screws.

• OPERATION

The oil flow is allowed from D1 (D2) to U1 (U2) and is stopped in the opposite way from U1 (U2) to D1 (D2) up to the spring setting value. Free oil flow from U1 (U2) to D1 (D2) is strictly possible when the pilot pressure in D2 and U2 (D1 and U1) is strong enough to pilot the valve poppet.

Use the following formula to assert the applicable pilot pressure:

$$(\text{valve setting} - \text{load pressure}) \div \text{pilot ratio} = \text{pilot pressure}$$

For example:

If your pilot ratio is 1:7, your setting pressure is 250 bar and your load pressure is 130 bar then you will need 30 bar pilot pressure in order to displace the load, $[(250 \text{ bar} - 130 \text{ bar}) \div 7 = 17 \text{ bar}]$.

Counterpressure in D1 (D2) increase the setting value (1:1 ratio) of the poppet spring and negatively affect the pilot pressure (1:1 ratio).

Use of two check-valves between D1 (D2) and T avoids cavitation on the pressure line during relief operation.

• PERFORMANCE

Maximum flow: 70 l/min

Maximum Pressure:

- Aluminium body 210 bar
- Steel body 350 bar

Application range with standard springs:

- 5 - 210 bar, pressure increase= 47 bar/turn (test setting: 170 bar at 5 l/min)
- 50 - 350 bar, pressure increase= 99 bar/turn (test setting: 280 bar at 5 l/min)

• CROSS SECTION

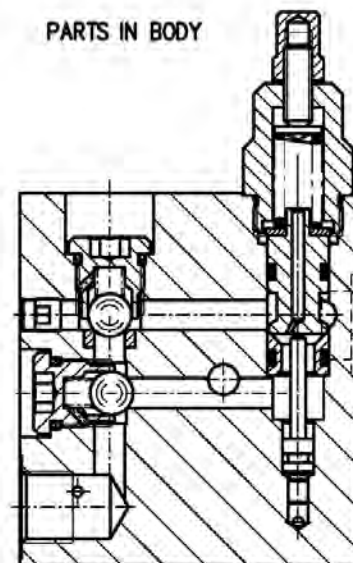

Oil leaks from U1 (U2) to D1 (D2): 0,25 cc/minute (5 drops) at 210 bar and 80% of the spring setting value with oil viscosity of 46 cSt.

Pilot ratio: 1:7

Working temperature:

- Minimum -25°C max 90°C with standard BUNA N gaskets

- Minimum -20°C max 120°C with optional VITON gaskets

Spare parts KIT:

Screws and Seals (Ordering code: 5KTM0OMS04)

• RECOMMANDATIONS

Fluid: best use mineral oil with viscosity ranging between 10 and 200 cSt

Filter: see General Informations.

Weight:

- aluminium body: 3,5 kg

- steel body: 6,9 kg

Material: internal components made out of high-grade steel duly treated and fabricated.

For more information please ask our Technical Department.

Variations and modifications of technical features and dimensions are reserved. HANSA-TMP s.r.l. also reserves the right to stop production of each and any model listed in the catalogue with no notice.

Copyrights on the text contained herein belong to HANSA-TMP s.r.l.. Partial and full reproductions or copies of this catalogue are forbidden.

• **RATING DIAGRAMS**

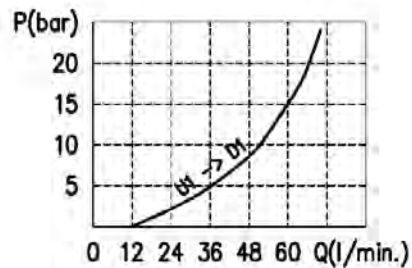
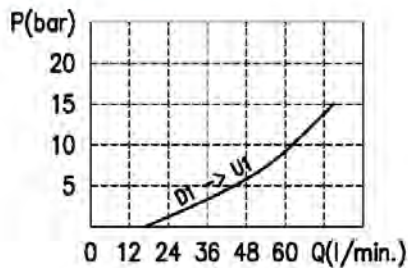

Oil viscosity 46 cSt

• **CODE NUMBER**

VABAL / SC / F 12/OMS/□□ . S . □□ . PG . □□ / □□

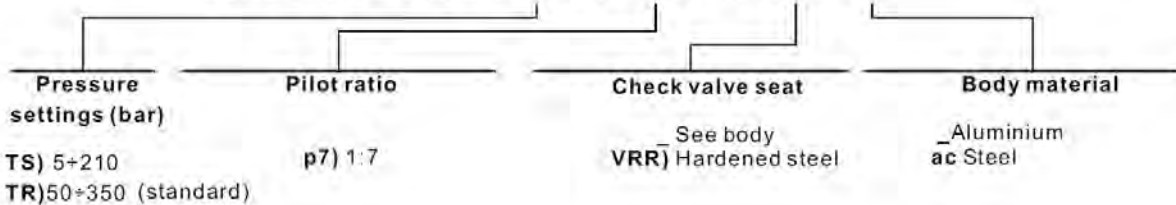

• DIMENSIONS (mm)

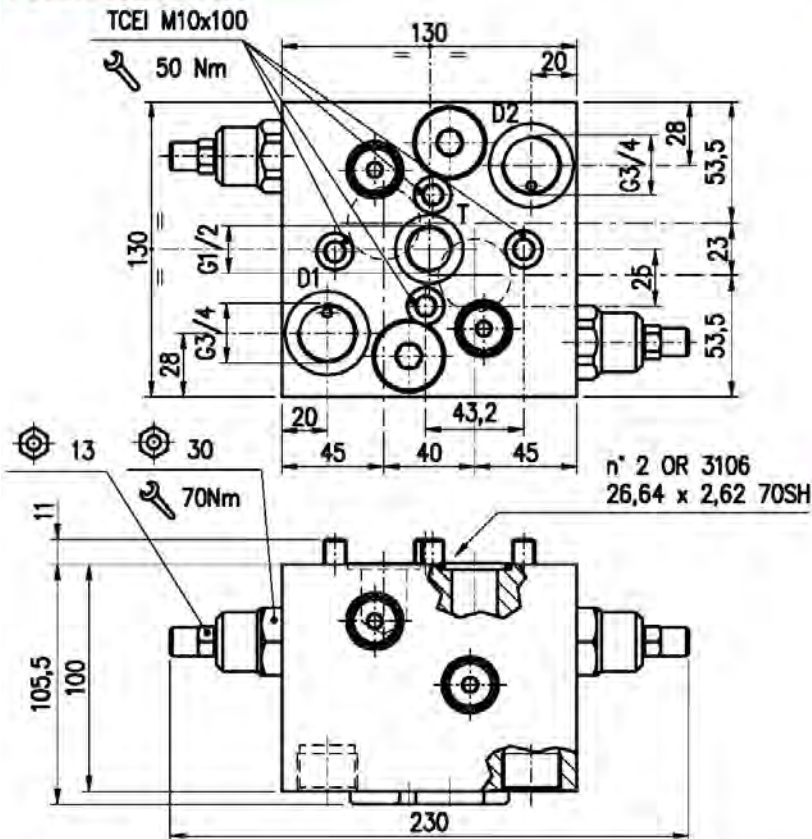

• HYDRAULIC DIAGRAM

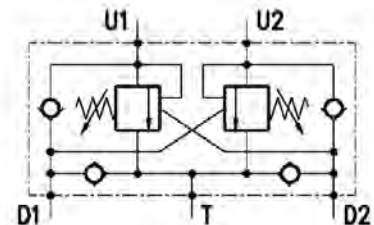

• ASSEMBLY DIAGRAM

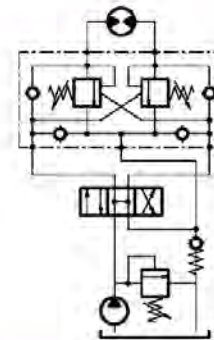

• DESCRIPTION

Cross-line, relief valves for motion control, anti-shock and anti-cavitation, face mounting for Sauer-Danfoss motor OMT Series including OR and Screws.

• OPERATION

The oil flow is allowed from D1 (D2) to U1 (U2) and is stopped in the opposite way from U1 (U2) to D1 (D2) up to the spring setting value. Free oil flow from U1 (U2) to D1 (D2) is strictly possible when the pilot pressure in D2 and U2 (D1 and U1) is strong enough to pilot the valve poppet.

Use the following formula to assert the applicable pilot pressure:

$$(\text{valve setting} - \text{load pressure}) \div \text{pilot ratio} = \text{pilot pressure}$$

For example:

If your pilot ratio is 1:7, your setting pressure is 250 bar and your load pressure is 130 bar then you will need 30 bar pilot pressure in order to displace the load. $[(250 \text{ bar} - 130 \text{ bar}) \div 7 = 17 \text{ bar}]$.

Counterpressure in D1 (D2) increase the setting value (1:1 ratio) of the poppet spring and negatively affect the pilot pressure (1:1 ratio).

Use of two check-valves between D1 (D2) and T avoids cavitation on the pressure line during relief operation.

• PERFORMANCE

Maximum flow: 100 l/min

Maximum Pressure:

- Aluminium body 210 bar
- Steel body 350 bar

Application range with standard springs:

- 5 - 210 bar, pressure increase = 37 bar/turn (test setting: 170 bar at 5 l/min)
- 50 - 350 bar, pressure increase = 63 bar/turn (test setting: 280 bar at 5 l/min) STANDARD

Oil leaks from U1 (U2) to D1 (D2): 0,25 cc/minute (5 drops) at 210 bar and 80% of the spring

• CROSS SECTION

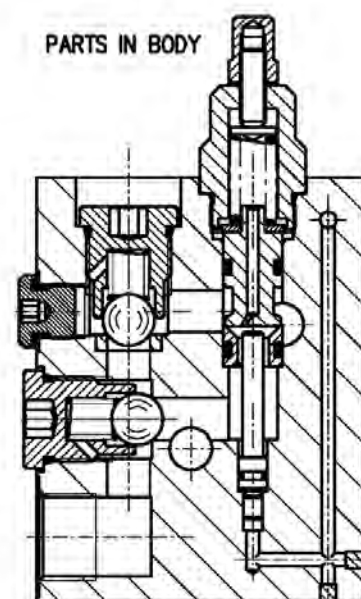

**MOTION CONTROL VALVES (SAUER-DANFOSS MOTOR)
VABAL/SC/F/34/OMT**

HANSA · TMP s.r.l

setting value with oil viscosity of 46 cSt.

Pilot ratio: 1:7

Working temperature:

- Minimum -25°C max 90°C with standard BUNA N gaskets
- Minimum -20°C max 120°C with optional VITON gaskets

Spare parts KIT:

Screws and Seals (Ordering code: 5KTM00MT04)

• RECOMMANDATIONS

Fluid: best use mineral oil with viscosity ranging between 10 and 200 cSt

Filter: see General Informations.

Weight:

- aluminium body: 4,8 kg
- steel body: 9,5 kg

Material: internal components made out of high-grade steel duly treated and fabricated.

For more information please ask our Technical Department.

Variations and modifications of technical features and dimensions are reserved. HANSA-TMP s.r.l. also reserves the right to stop production of each and any model listed in the catalogue with no notice.

Copyrights on the text contained herein belong to HANSA-TMP s.r.l.. Partial and full reproductions or copies of this catalogue are forbidden.

• RATING DIAGRAMS

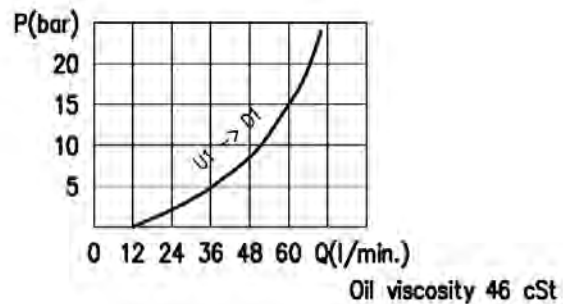
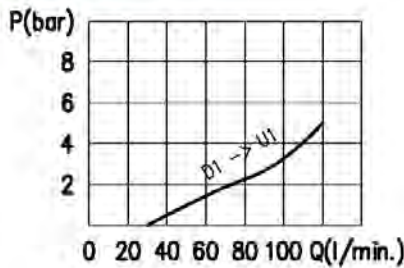

• CODE NUMBER

VABAL / SC / F 34 / OMT / □□ . S . □□ . PG . □□ / □□

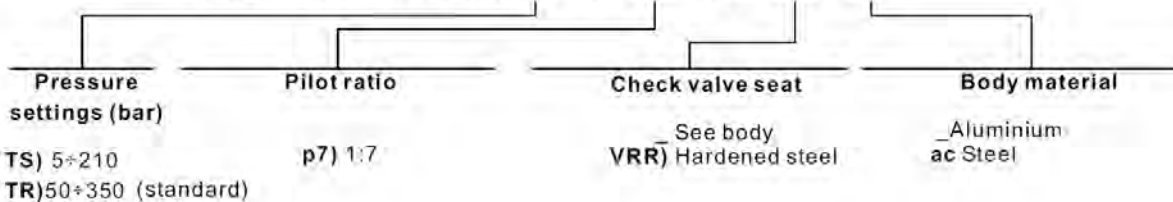

• DIMENSIONS (mm)

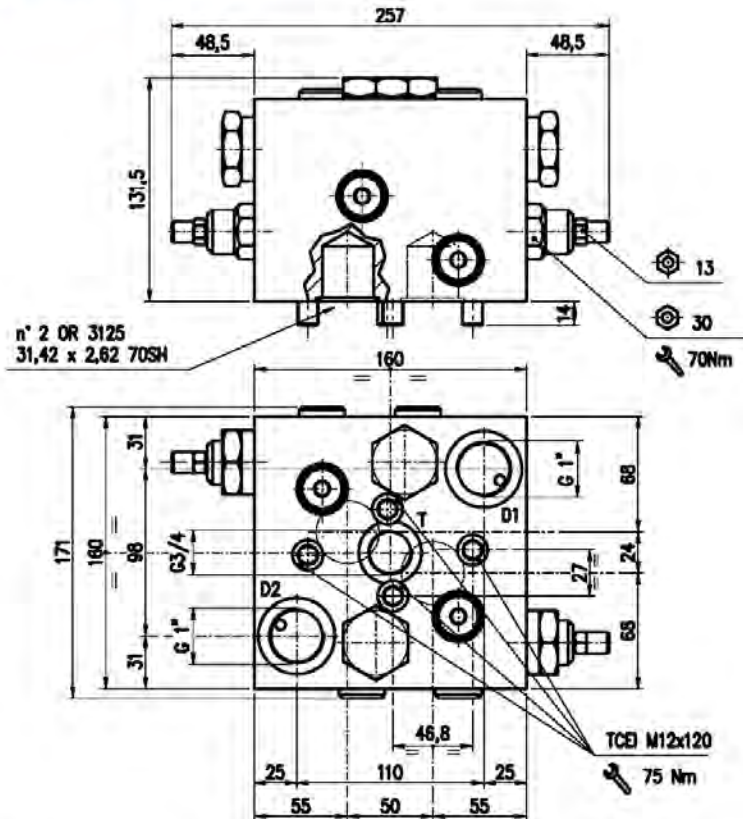

• HYDRAULIC DIAGRAM

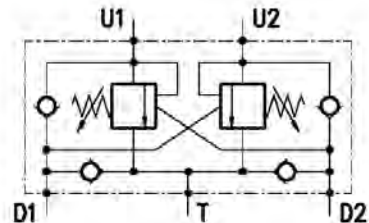

• ASSEMBLY DIAGRAM

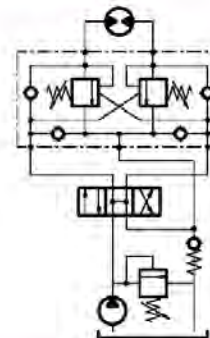

• DESCRIPTION

Cross-line, relief valves for motion control, anti-shock and anti-cavitation, face mounting for Sauer-Danfoss motor OMV Series including OR and Screws.

• OPERATION

The oil flow is allowed from D1 (D2) to U1 (U2) and is stopped in the opposite way from U1 (U2) to D1 (D2) up to the spring setting value. Free oil flow from U1 (U2) to D1 (D2) is strictly possible when the pilot pressure in D2 and U2 (D1 and U1) is strong enough to pilot the valve poppet.

Use the following formula to assert the applicable pilot pressure:

$$(\text{valve setting} - \text{load pressure}) \div \text{pilot ratio} = \text{pilot pressure}$$

For example:

If your pilot ratio is 1:7, your setting pressure is 250 bar and your load pressure is 130 bar then you will need 30 bar pilot pressure in order to displace the load. $[(250 \text{ bar} - 130 \text{ bar}) \div 7 = 17 \text{ bar}]$.

Counterpressure in D1 (D2) increase the setting value (1:1 ratio) of the poppet spring and negatively affect the pilot pressure (1:1 ratio).

Use of two check-valves between D1 (D2) and T avoids cavitation on the pressure line during relief operation. To obtain immediate valve response and no pressure drop, preferably mount this valve next to the application to check.

• PERFORMANCE

Maximum flow: 180 l/min

Maximum Pressure:

- aluminium body 210 bar

- steel body 350 bar

Application range with standard springs:

- 5 - 210 bar, pressure increase = 35 bar/turn (test setting: 170 bar at 5 l/min)

- 50 - 350 bar, pressure increase = 89 bar/turn (test setting: 280 bar at 5 l/min) STANDARD

• CROSS SECTION

PARTS IN BODY

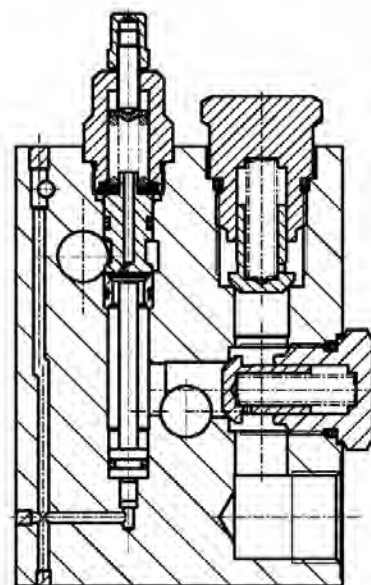

Oil leaks from U1 (U2) to D1 (D2): 0,25 cc/minute (5 drops) at 210 bar and 80% of the spring setting value with oil viscosity of 46 cSt.

Pilot ratio: 1:7

Working temperature:

- minimum -25°C max 90°C with standard BUNA N gaskets

- minimum -20°C max 120°C with optional VITON gaskets

Spare parts KIT: screws and seals (Ordering code: 5KTM00MV01)

• RECOMMANDATIONS

Fluid: best use mineral oil with viscosity ranging between 10 and 200 cSt

Filter: see General Informations.

Weight:

- aluminium body: 9.5 kg

- steel body: 18kg

Material: internal components made out of high-grade steel duly treated and fabricated.

For more information please ask our Technical Department.

Variations and modifications of technical features and dimensions are reserved. HANSA-TMP s.r.l. also reserves the right to stop production of each and any model listed in the catalogue with no notice.

Copyrights on the text contained herein belong to HANSA-TMP s.r.l.. Partial and full reproductions or copies of this catalogue are forbidden.

• RATING DIAGRAMS

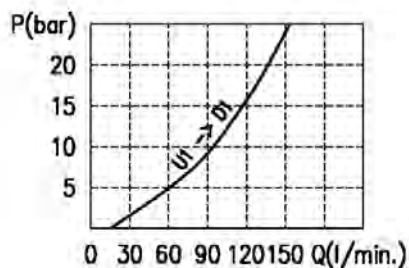
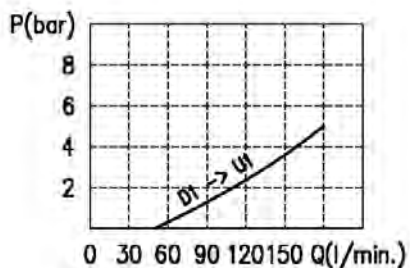

Oil viscosity 46 cSt

• CODE NUMBER

VABAL / SC / F 100 / OMV / □□ . S . □□ . PG . □□ / □□

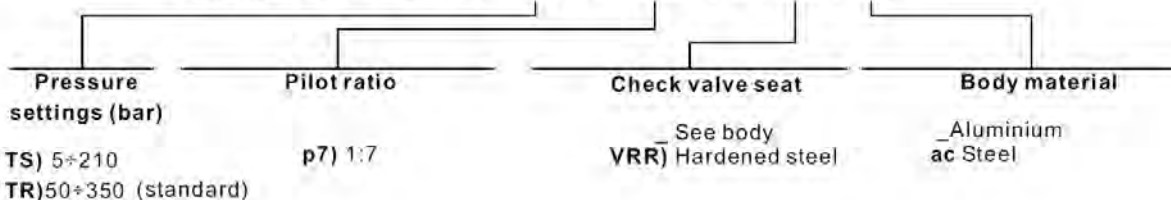

**MOTION CONTROL VALVES (SAUER-DANFOSS MOTOR)
VABAL/SC/F/A 12/OMR**

HANSA · TMP s.r.l

Oil leaks from U1 (U2) to D1 (D2): 0,25 cc/minute (5 drops) at 210 bar and 80% of the spring setting value with oil viscosity of 46 cSt.

Pilot ratio:

- 1:3 Standard
- 1:1,2

Working temperature:

- minimum -25°C max 90°C with standard BUNA N gaskets
- minimum -20°C max 120°C with optional VITON gaskets

Spare parts KIT:

screws and seals (Ordering code: 5KTM00MR05)

• **RECOMMANDATIONS**

Fluid: best use mineral oil with viscosity ranging between 10 and 200 cSt

Filter: see General Informations.

Weight:

- aluminium body: 3.1 kg
- steel body: 6 kg

Material: internal components made out of high-grade steel duly treated and fabricated.

For more information please ask our Technical Department.

Variations and modifications of technical features and dimensions are reserved. HANSA-TMP s.r.l. also reserves the right to stop production of each and any model listed in the catalogue with no notice.

Copyrights on the text contained herein belong to HANSA-TMP s.r.l.. Partial and full reproductions or copies of this catalogue are forbidden.

• **RATING DIAGRAMS**

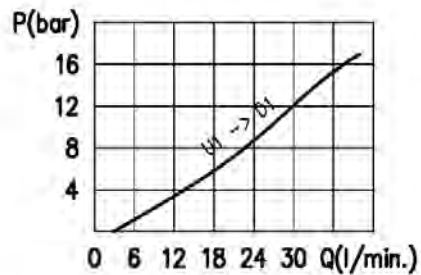
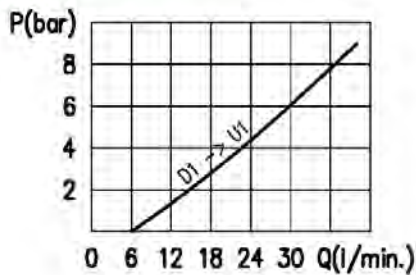

Oil viscosity 46 cSt

• **CODE NUMBER**

VABAL / SC / F/A 12/OMR/□□ . S . □□ . PG . □□ / □□

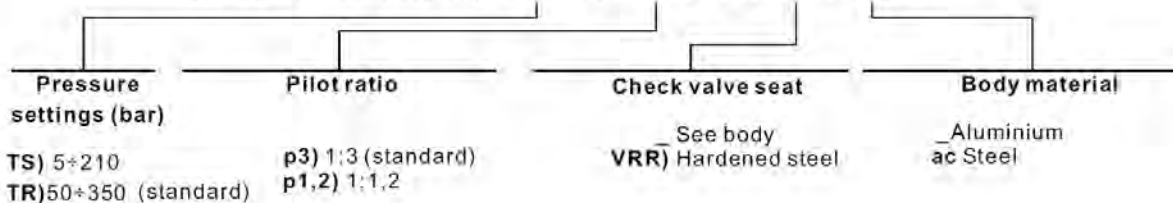

• DIMENSIONS (mm)

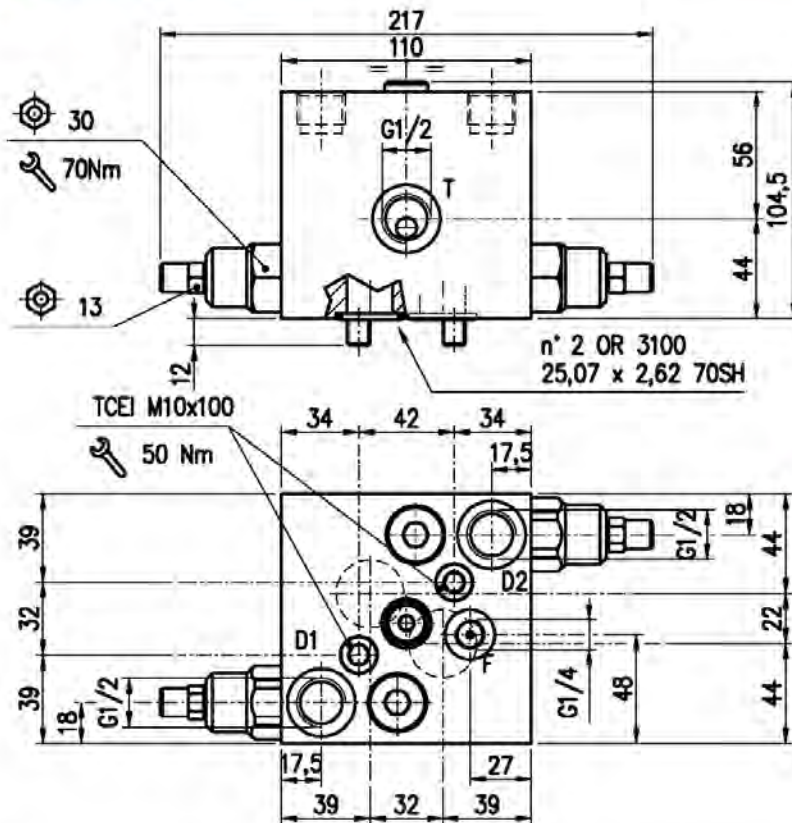

• HYDRAULIC DIAGRAM

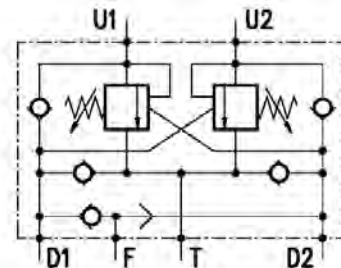

• ASSEMBLY DIAGRAM

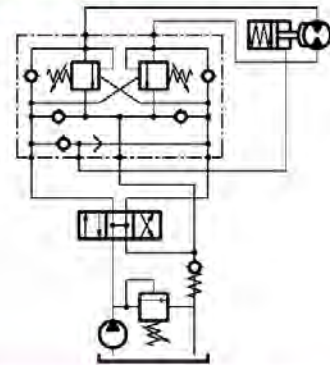

• DESCRIPTION

Cross-line, relief valves for motion control, anti-shock and anti-cavitation with connection for hydraulic brakes release., face mounting for Sauer-Danfoss motor OMS Series including OR and Screws.

• OPERATION

The oil flow is allowed from D1 (D2) to U1 (U2) and is stopped in the opposite way from U1 (U2) to D1 (D2) up to the spring setting value. Free oil flow from U1 (U2) to D1 (D2) is strictly possible when the pilot pressure in D2 and U2 (D1 and U1) is strong enough to pilot the valve poppet.

Use the following formula to assert the applicable pilot pressure:

$$(\text{valve setting} - \text{load pressure}) \div \text{pilot ratio} = \text{pilot pressure}$$

For example:

If your pilot ratio is 1:7, your setting pressure is 250 bar and your load pressure is 130 bar then you will need 30 bar pilot pressure in order to displace the load. $[(250 \text{ bar} - 130 \text{ bar}) \div 7 = 17 \text{ bar}]$.

Counterpressure in D1 (D2) increase the setting value (1:1 ratio) of the poppet spring and negatively affect the pilot pressure (1:1 ratio).

Use of two check-valves between D1 (D2) and T avoids cavitation on the pressure line during relief operation. The special shuttle valve allows releasing of the hydraulic parking brakes.

• PERFORMANCE

Maximum flow: 70 l/min

Maximum Pressure:

- Aluminium body 210 bar

- Steel body 350 bar

Application range with standard springs:

- 5 - 210 bar, pressure increase= 47 bar/turn (test setting: 170 bar at 5 l/min)

- 50 - 350 bar, pressure increase= 99 bar/turn (test setting: 280 bar at 5 l/min)

Oil leaks from U1 (U2) to D1 (D2): 0,25 cc/minute (5 drops) at 210 bar and 80% of the spring

• CROSS SECTION

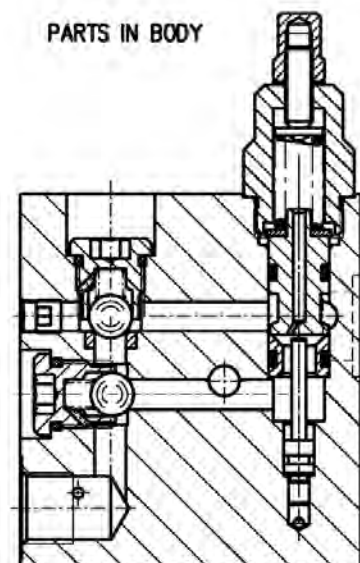

**MOTION CONTROL VALVES (SAUER-DANFOSS MOTOR)
VABAL/SC/F/A/12/OMS**

HANSA · TMP s.r.l.

setting value with oil viscosity of 46 cSt.

Pilot ratio:

- 1:7 (standard)
- 1:3

Working temperature:

- Minimum -25°C max 90°C with standard BUNA N gaskets
- Minimum -20°C max 120°C with optional VITON gaskets

Spare parts KIT:

Screws and Seals (Ordering code: 5KTM00MS04)

• **RECOMMANDATIONS**

Fluid: best use mineral oil with viscosity ranging between 10 and 200 cSt

Filter: see General Informations.

Weight:

- aluminium body: 3,5 kg
- steel body: 6,9 kg

Material: internal components made out of high-grade steel duly treated and fabricated.

For more information please ask our Technical Department.

Variations and modifications of technical features and dimensions are reserved. HANSA-TMP s.r.l. also reserves the right to stop production of each and any model listed in the catalogue with no notice.

Copyrights on the text contained herein belong to HANSA-TMP s.r.l.. Partial and full reproductions or copies of this catalogue are forbidden.

• **RATING DIAGRAMS**

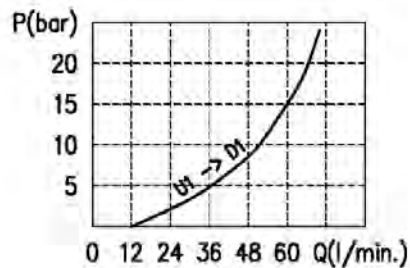
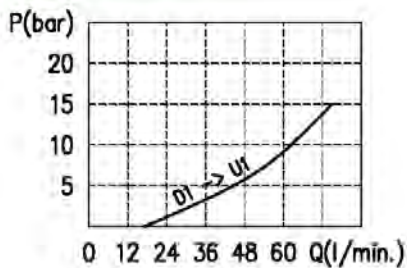

Oil viscosity 46 cSt

• **CODE NUMBER**

VABAL / SC / F / A 12 / OMS / □□ . S . □□ . PG . □□ / □□

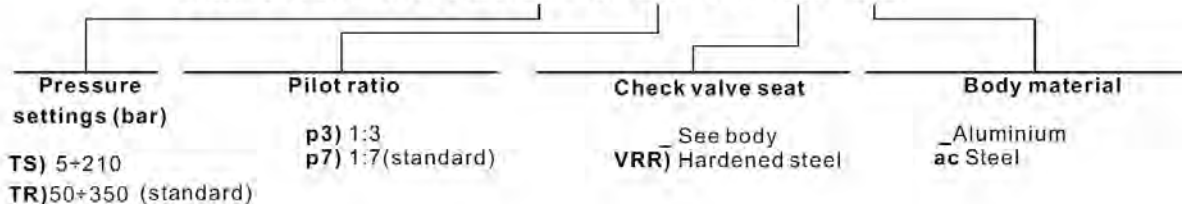

• DIMENSIONS (mm)

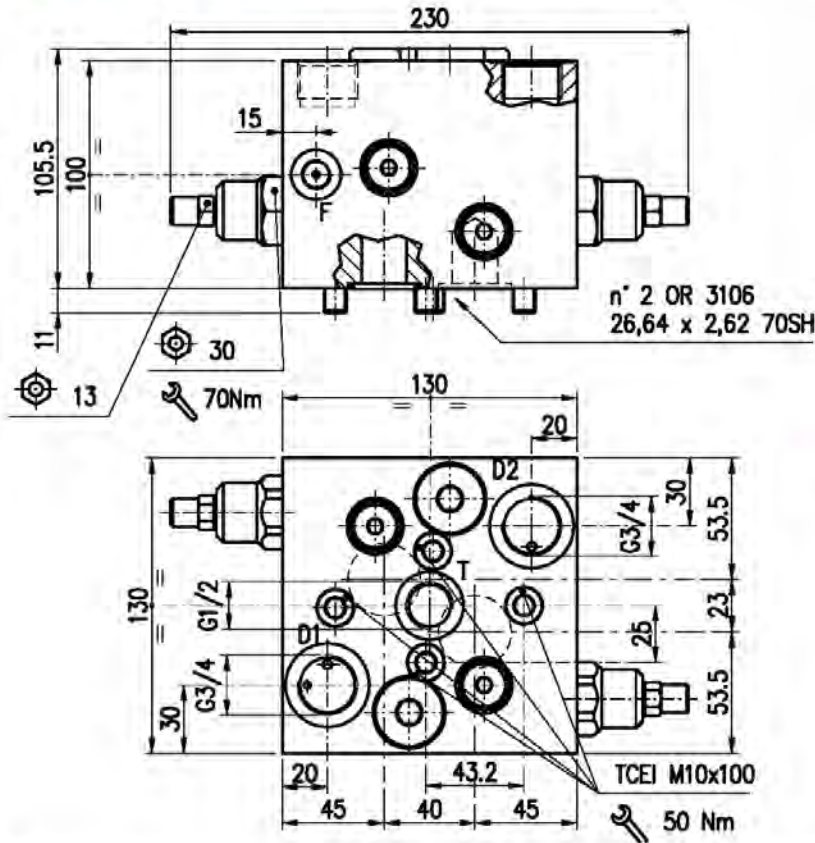

• HYDRAULIC DIAGRAM

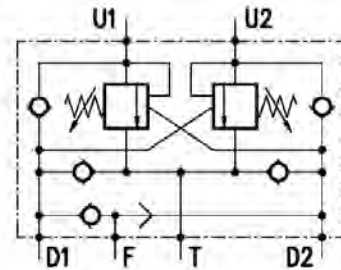

• ASSEMBLY DIAGRAM

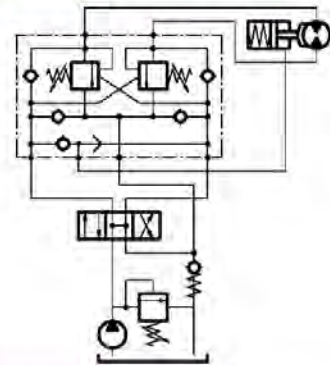

• DESCRIPTION

Cross-line, relief valves for motion control, anti-shock and anti-cavitation, face mounting for Sauer-Danfoss motor OMT Series including OR and Screws.

• OPERATION

The oil flow is allowed from D1 (D2) to U1 (U2) and is stopped in the opposite way from U1 (U2) to D1 (D2) up to the spring setting value. Free oil flow from U1 (U2) to D1 (D2) is strictly possible when the pilot pressure in D2 and U2 (D1 and U1) is strong enough to pilot the valve poppet.

Use the following formula to assert the applicable pilot pressure:

$$(\text{valve setting} - \text{load pressure}) \div \text{pilot ratio} = \text{pilot pressure}$$

For example:

If your pilot ratio is 1:3, your setting pressure is 250 bar and your load pressure is 130 bar then you will need 30 bar pilot pressure in order to displace the load. $[(250 \text{ bar} - 130 \text{ bar}) \div 3 = 40 \text{ bar}]$.

Counterpressure in D1 (D2) increase the setting value (1:1 ratio) of the poppet spring and negatively affect the pilot pressure (1:1 ratio).

Use of two check-valves between D1 (D2) and T avoids cavitation on the pressure line during relief operation. The special shuttle valve allows releasing of the hydraulic parking brakes.

• PERFORMANCE

Maximum flow: 100 l/min

Maximum Pressure:

- Aluminium body 210 bar
- Steel body 350 bar

Application range with standard springs:

- 5 - 210 bar, pressure increase= 37 bar/turn (test setting: 170 bar at 5 l/min)
- 50 - 350 bar, pressure increase= 63 bar/turn (test setting: 280 bar at 5 l/min) STANDARD

Oil leaks from U1 (U2) to D1 (D2): 0,25 cc/minute (5 drops) at 210 bar and 80% of the spring

• CROSS SECTION

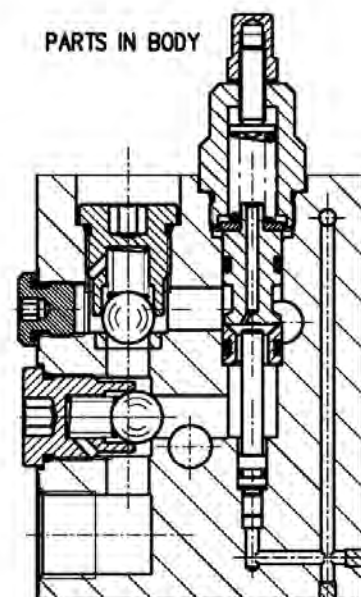

**MOTION CONTROL VALVES (SAUER-DANFOSS MOTOR)
VABAL/SC/F/A 34/OMT**

HANSA · TMP s.r.l

setting value with oil viscosity of 46 cSt.

Pilot ratio:

1:3

Working temperature:

- Minimum -25°C max 90°C with standard BUNA N gaskets
- Minimum -20°C max 120°C with optional VITON gaskets

Spare parts KIT:

Screws and Seals (Ordering code: 5KTM00MT04)

• RECOMMANDATIONS

Fluid: best use mineral oil with viscosity ranging between 10 and 200 cSt

Filter: see General Informations.

Weight:

- aluminium body: 4,8 kg
- steel body: 9,5 kg

Material: internal components made out of high-grade steel duly treated and fabricated.

For more information please ask our Technical Department.

Variations and modifications of technical features and dimensions are reserved. HANSA-TMP s.r.l. also reserves the right to stop production of each and any model listed in the catalogue with no notice.

Copyrights on the text contained herein belong to HANSA-TMP s.r.l.. Partial and full reproductions or copies of this catalogue are forbidden.

• RATING DIAGRAMS

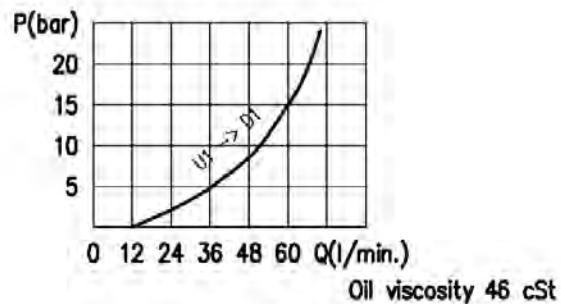
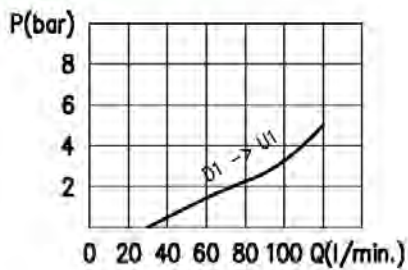

• CODE NUMBER

VABAL /SC /F/A 34/OMT/□□ . S . □□ . PG . □□ / □□

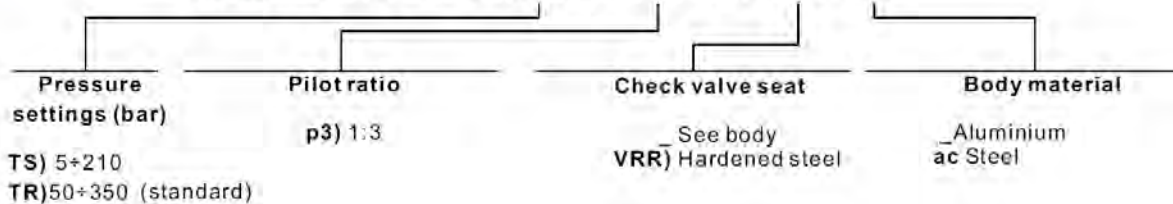

FLOW CONTROL VALVES INDEX

Description	type	code	page
Needle adjustable valve	VSRB / F / 12 / OMR	A.1810.200	120
2 way pressure compensated regulator	VPR / 2 / SLS / 12 OMR / SIX	A.1850.200	122
2 way pressure compensated regulator	VPR / 2 / SLS / 12 OMR / DEX	A.1850.201	124
3 way pressure compensated regulator	VPR / 3 / ET / 12 / OMR	A.18A0.200	126
3 way press. comp. reg. with relief valve	VPR / 3 / ET / VMP 12 / OMR	A.18B0.200	128
3 way press. comp. proportional regulator	VPR / 3 / EP 38 / C / CEP / OMM	A.18F0.100	130
3 way pressure compensated regulator	VPR / 3 / EP 12 / OMR	A.18F0.200	132
3 way press. comp. proportional regulator	VPR / 3 / EP 12 / OMR / CEP	A.18F0.205	134
3 way pressure compensated regulator	VPR / 3 / EP 12 / OMR / VG	A.18F0.210	136
3 way pressure compensated regulator	VPR / 3 / EP 12 / OMS	A.18F0.300	138

• DIMENSIONS (mm)

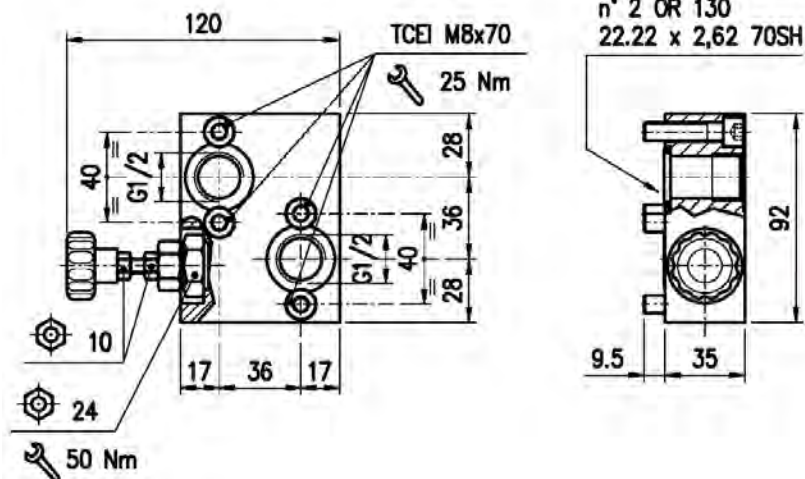

• HYDRAULIC DIAGRAM

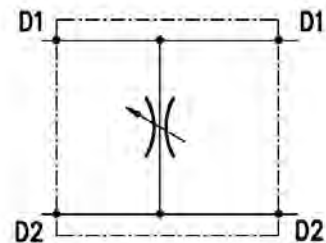

• ASSEMBLY DIAGRAM

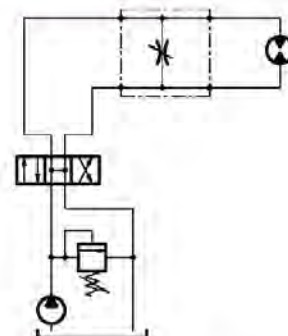

• DESCRIPTION

Needle adjustable valves, double acting, face mounting for Sauer-Danfoss motor OMR Series including OR and Screws.

• OPERATION

The valve capacity can be adjusted by variation of the oil flow section.

• PERFORMANCE

Maximum flow: 25 l/min.

Maximum Pressure: 350 bar

Working temperature: minimum -25°C max 90°C with standard BUNAN gaskets

Spare parts KIT: screws and Seals (Ordering code: 5KT0OMR00)

• RECOMMANDATIONS

Fluid: best use mineral oil with viscosity ranging between 10 and 200 cSt

Filter: see General Informations.

Weight:

- Alluminium body: 0,6kg;

- Steel body: 1kg

Material: internal components made out of high-grade steel duly treated and fabricated.

For more information please ask our Technical Department.

Variations and modifications of technical features and dimensions are reserved. HANSA-TMP s.r.l. also reserves the right to stop production of each and any model listed in the catalogue with no notice.

• CROSS SECTION

PARTS IN BODY

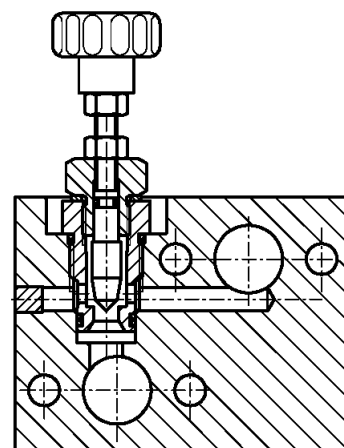

• ADJUSTMENTS



• CODE NUMBER

VSRB/F/12/OMR/□

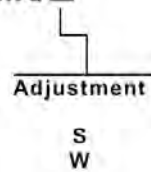

• DIMENSIONS (mm)

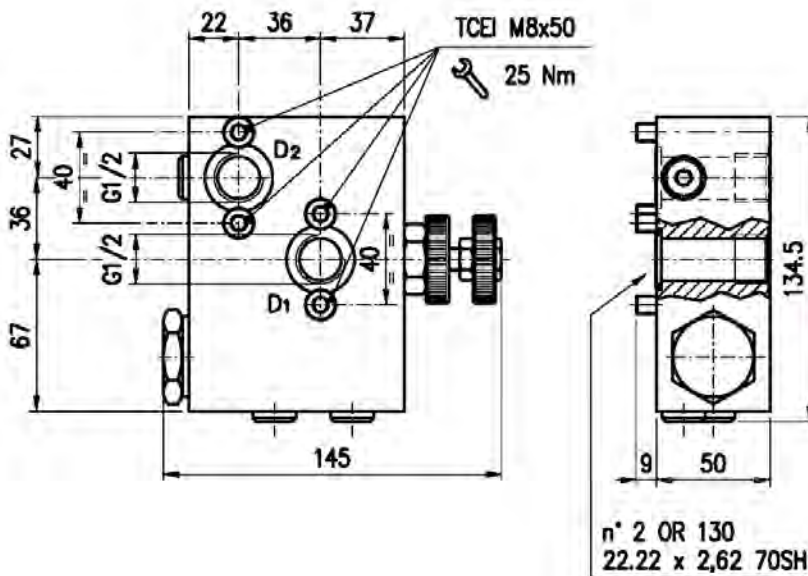

• HYDRAULIC DIAGRAM

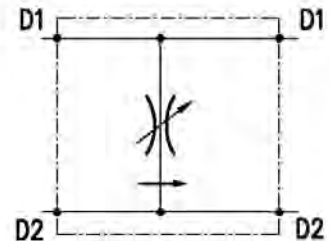

• ASSEMBLY DIAGRAM

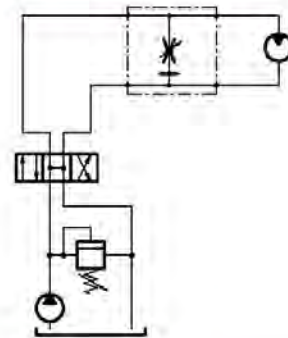

• DESCRIPTION

2-ways flow regulator, pressure compensated, face mounting for Sauer-Danfoss motor OMR Series, including OR and Screws.

• OPERATION

The valve is designed to provide flow adjustment from D1-U1 to D2-U2 by a variation of the oil flow section. Best performance of the valve is assured when the flow in E is at least 10% bigger than in C. Pressure variations in C do not alter the checked oil flow.

• PERFORMANCE

Maximum flow: 50 l/min.

Maximum Pressure:

Aluminium body 210 bar

Steel body 350 bar

Maximum pressure compensation error: see performance graphs.

Working temperature:

- Minimum -25°C max 90°C with standard BUNAN gaskets

- Minimum -20°C max 120°C with VITON gaskets on request

Spare parts KIT:

Screws and Seals (Ordering code: 5KTM00MR03)

• RECOMMANDATIONS

Fluid: best use mineral oil with viscosity ranging between 10 and 200 cSt

Filter: see page Z.9000.000.

Weight:

aluminium body 1,7 kg - steel body 3,4 kg

Material: internal components made out of high-grade steel duly treated and fabricated.

• CROSS SECTION

PARTS IN BODY

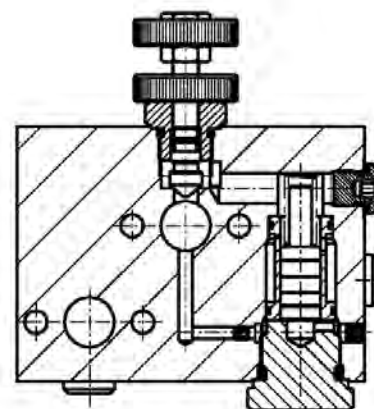

For more information please ask our Technical Department.

Variations and modifications of technical features and dimensions are reserved. **HANSA-TMP s.r.l.** also reserves the right to stop production of each and any model listed in the catalogue with no notice.

Copyrights on the text contained herein belong to **HANSA-TMP s.r.l.**. Partial and full reproductions or copies of this catalogue are forbidden.

• RATING DIAGRAMS

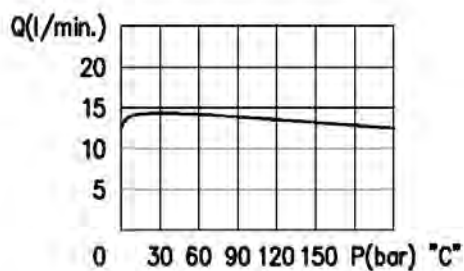

Oil viscosity 46 cSt

• CODE NUMBER

VPR /2/ SLS/12 OMR/SIX / □□.V

Body material

_ Aluminium
 ac Steel

• DIMENSIONS (mm)

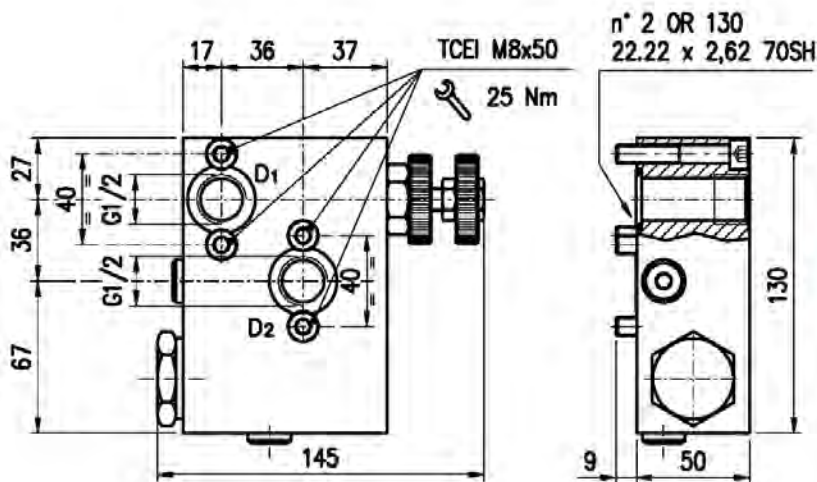

• HYDRAULIC DIAGRAM

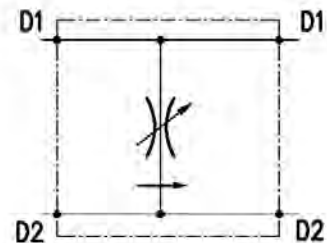

• ASSEMBLY DIAGRAM

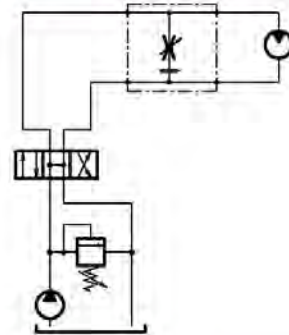

• DESCRIPTION

2-ways flow regulator, pressure compensated, face mounting for Sauer-Danfoss motor OMR Series, including OR and Screws.

• OPERATION

The valve is designed to provide flow adjustment from D1-U1 to D2-U2 by a variation of the oil flow section. Best performance of the valve is assured when the flow in D1-U1 is at least 10% bigger than in D2-U2. Pressure variations in D2-U2 do not alter the checked oil flow.

• PERFORMANCE

Maximum flow: 50 l/min.

Maximum Pressure:

- Aluminium body 210 bar
- Steel body 350 bar

Maximum pressure compensation error: see performance graphs.

Working temperature:

- Minimum -25°C max 90°C with standard BUNAN gaskets
- Minimum -20°C max 120°C with VITON gaskets on request

Spare parts KIT:

Screws and Seals (Ordering code: 5KTM00MR03)

• RECOMMENDATIONS

Fluid: best use mineral oil with viscosity ranging between 10 and 200 cSt

Filter: see page Z.9000.000.

Weight:

aluminium body 1,7 kg - steel body 3,4 kg

• CROSS SECTION

PARTS IN BODY

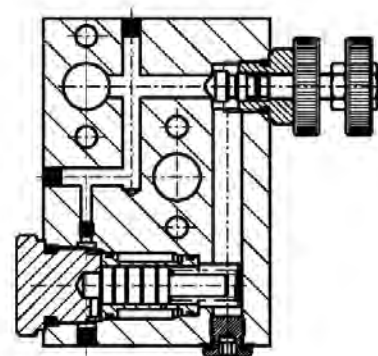

Material: internal components made out of high-grade steel duly treated and fabricated.

For more information please ask our Technical Department.

Variations and modifications of technical features and dimensions are reserved. **HANSA-TMP s.r.l.** also reserves the right to stop production of each and any model listed in the catalogue with no notice.

Copyrights on the text contained herein belong to **HANSA-TMP s.r.l.**. Partial and full reproductions or copies of this catalogue are forbidden.

• RATING DIAGRAMS

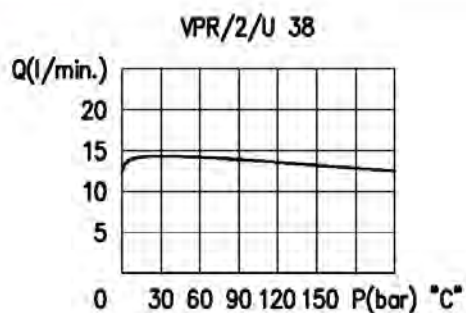

Oil viscosity 46 cSt

• CODE NUMBER

VPR /2/ SLS/12 OMR/DEX / □□.V

Body material

_ Aluminium
ac Steel

• DIMENSIONS (mm)

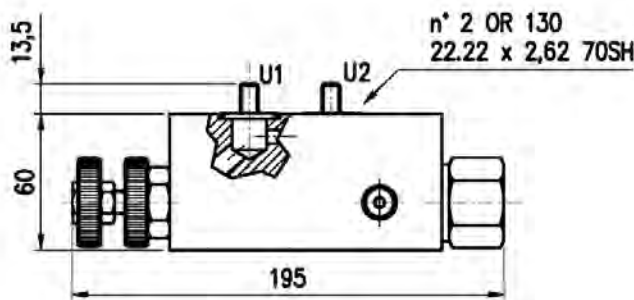
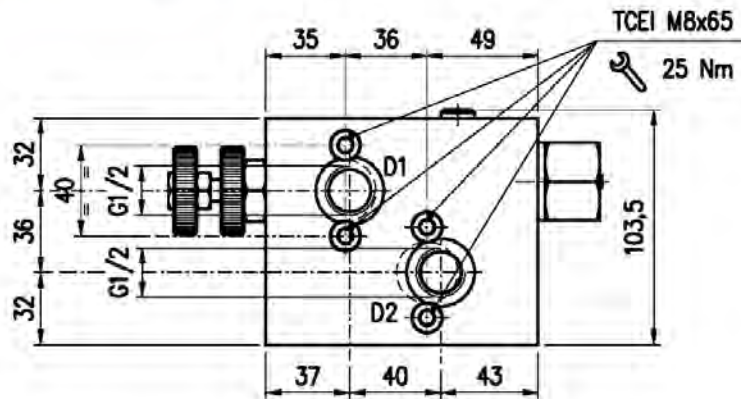

• HYDRAULIC DIAGRAM

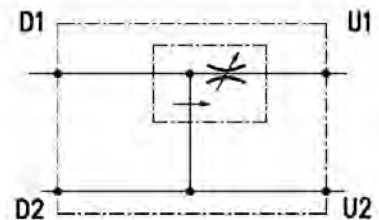

• ASSEMBLY DIAGRAM

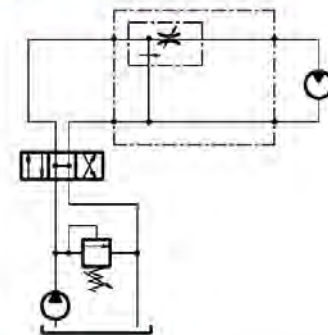

• DESCRIPTION

3-ways flow regulator, pressure compensated, face mounting for Sauer-Danfoss motor OMR Series, including OR and Screws.

• OPERATION

The valve is designed to provide flow adjustment from D1 to U1 by a variation of the oil flow section. Exceeding flow is concurrently discharged in D2-U2 while a pressure built-in relief valve provides operative pressure control on U1. Best performance of the valve is assured when the flow in D1 is at least 10% bigger than in U1. Pressure variations in U1 do not alter the checked oil flow. On the contrary, eventual back pressure in D2-U2 may cause inconstant capacity in U1.

• PERFORMANCE

Maximum flow: 50 l/min.

Maximum Pressure:

- aluminium body 210 bar
- steel body 350 bar

Maximum pressure compensation error: see performance graphs.

Working temperature:

- minimum -25°C max 90°C with standard BUNAN gaskets
- minimum -20°C max 120°C with VITON gaskets on request

Spare parts KIT: screws and seals (Ordering code: 5KTM0OMR02)

• RECOMMENDATIONS

Fluid: best use mineral oil with viscosity ranging between 10 and 200 cSt

Filter: see page Z.9000.000.

Weight: aluminium body 1.5 kg - steel body 3 kg

Material: internal components made out of high-grade steel duly treated and fabricated.

• CROSS SECTION

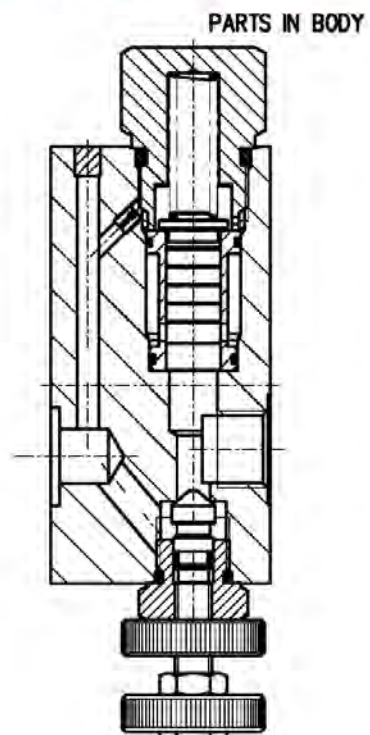

For more information please ask our Technical Department.

Variations and modifications of technical features and dimensions are reserved. HANSA-TMP s.r.l. also reserves the right to stop production of each and any model listed in the catalogue with no notice.

Copyrights on the text contained herein belong to HANSA-TMP s.r.l.. Partial and full reproductions or copies of this catalogue are forbidden.

• **RATING DIAGRAMS**

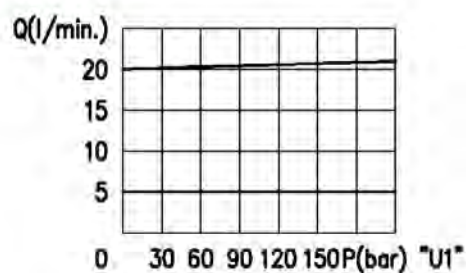

Oil viscosity 46 cSt

• **CODE NUMBER**

VPR/3/ET/OMR/ □□

Body material

Aluminium
ac Steel

• DIMENSIONS (mm)

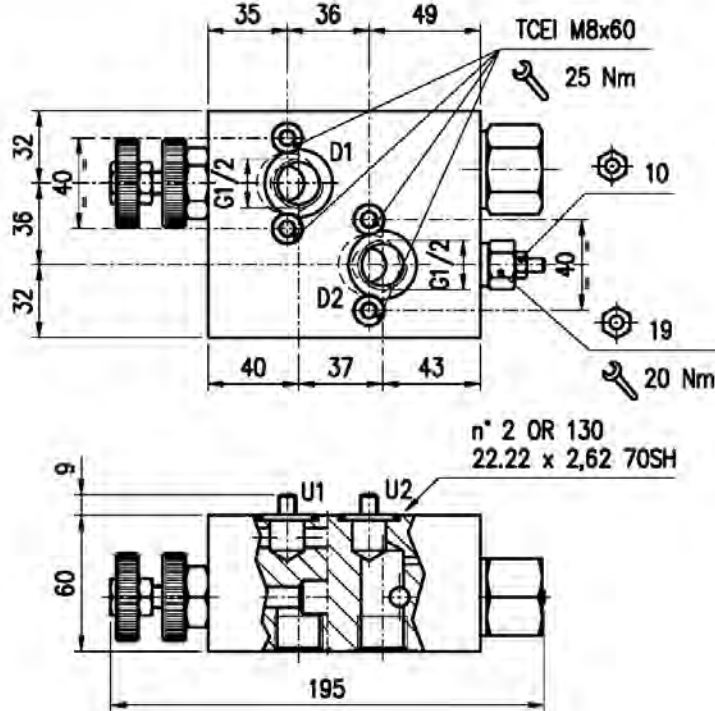

• HYDRAULIC DIAGRAM

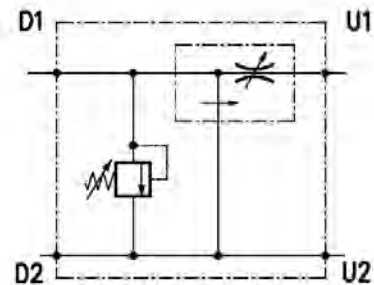

• ASSEMBLY DIAGRAM

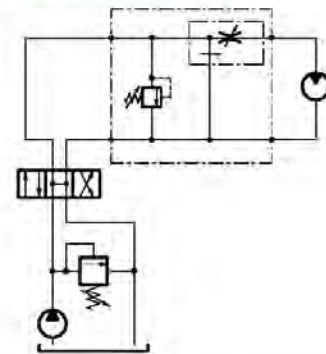

• DESCRIPTION

3-ways flow regulator, pressure compensated, with built-in relief valve on the checked way and exceeding flow to tank, face mounting for Sauer-Danfoss motor OMR Series, including OR and Screws.

• OPERATION

The valve is designed to provide flow adjustment from D1 to U1 by a variation of the oil flow section. Exceeding flow is concurrently discharged in D2-U2 while a pressure built-in relief valve provides operative pressure control on U1. Best performance of the valve is assured when the flow in D1 is at least 10% bigger than in U1. Pressure variations in U1 do not alter the checked oil flow. On the contrary, eventual back pressure in D2-U2 may cause inconstant capacity in U1.

• PERFORMANCE

Maximum flow: 50 l/min.

Maximum Pressure:

- Aluminium body 210 bar
- Steel body 350 bar

Maximum pressure compensation error: see performance graphs.

Working temperature:

- Minimum -25°C max 90°C with standard BUNAN gaskets
- Minimum -20°C max 120°C with VITON gaskets on request.

Spare parts KIT:

Screws and Seals (Ordering code: 5KTM00MR02)

• CROSS SECTION

PARTS IN BODY

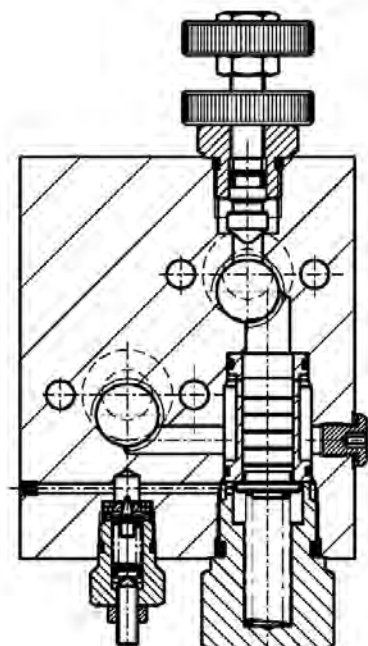

• RECOMMANDATIONS

Fluid: best use mineral oil with viscosity ranging between 10 and 200 cSt

Filter: see General Informations.

Weight:

- aluminium body 1,5 kg

- steel body 3 kg

Relief cartridge valve : consult our Technical Department.

Material: internal components made out of high-grade steel duly treated and fabricated.

For more information please ask our Technical Department.

Variations and modifications of technical features and dimensions are reserved. HANSA-TMP s.r.l. also reserves the right to stop production of each and any model listed in the catalogue with no notice.

Copyrights on the text contained herein belong to HANSA-TMP s.r.l.. Partial and full reproductions or copies of this catalogue are forbidden.

• RATING DIAGRAMS

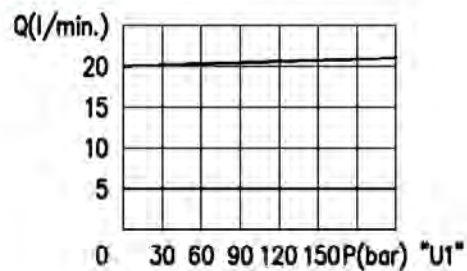

Oil viscosity 46 cSt

• CODE NUMBER

VPR/3/ET/VMP12/OMR/ □□

Body material

Aluminium
 ac Steel

• DIMENSIONS (mm)

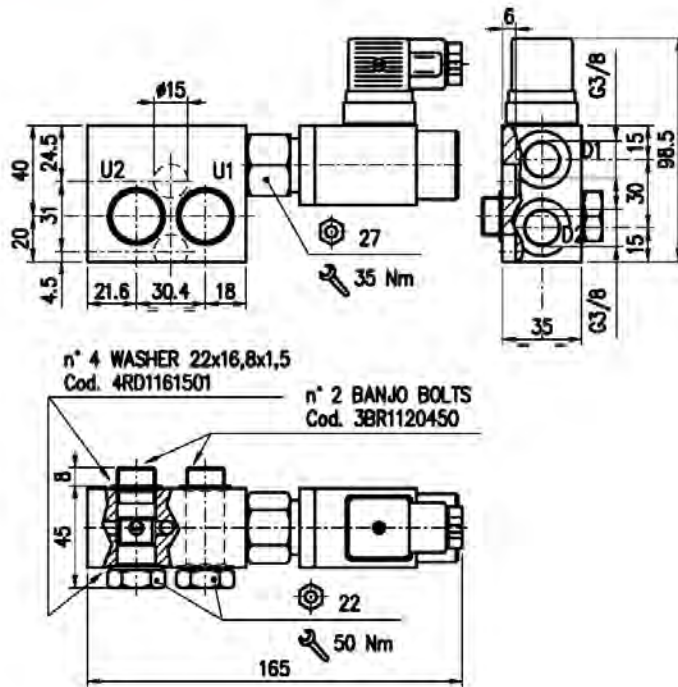

• HYDRAULIC DIAGRAM

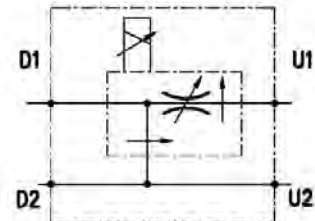

• ASSEMBLY DIAGRAM

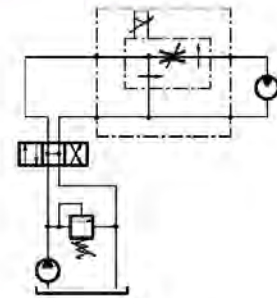

• DESCRIPTION

3-ways proportional flow regulator, pressure compensated and exceeding flow to pressure, face mounting for Sauer-Danfoss motor OMM Series, including OR and Screws.

• OPERATION

The valve is designed to keep constant flow in U1 and concurrently discharge in D2-U2 exceeding flow for other applications. Best performance of the valve is assured when the flow in D1 is at least 10% bigger than in U1. Pressure variations in U1 and D2-U2 do not alter the constant flow in U1. Make sure that a pressure relief valve is always used between the pump and the valve.

• PERFORMANCE

Maximum flow: 30 l/min.

Maximum Pressure:

- aluminium body 210 bar
- steel body 350 bar

Maximum pressure compensation error: see performance graphs.

Working temperature:

- Minimum -25°C max 90°C with standard BUNAN gaskets
- Minimum -20°C max 120°C with VITON gaskets on request

Spare parts KIT:

- banjo bolt (ordering code: 3BR1120450)
- external seals PP10W (ordering code: 5KT0103000)

• RECOMMENDATIONS

Fluid: best use mineral oil with viscosity ranging between 10 and 200 cSt

• CROSS SECTION

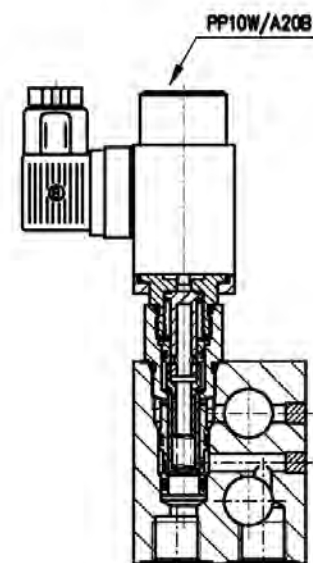

Filter: see General Informations.

Weight:

- aluminium body 0.8kg
- steel body 1,4 kg

Material: internal components made out of high-grade steel duly treated and fabricated.

For more information please ask our Technical Department.

Variations and modifications of technical features and dimensions are reserved. **HANSA-TMP s.r.l.** also reserves the right to stop production of each and any model listed in the catalogue with no notice.

Copyrights on the text contained herein belong to **HANSA-TMP s.r.l.**. Partial and full reproductions or copies of this catalogue are forbidden.

• RATING DIAGRAMS

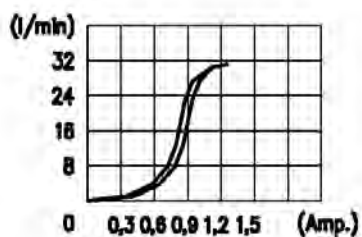

Oil viscosity 46 cSt

• CODE NUMBER

VPR/3/EP38/C/CEP 38/OMM/



• DIMENSIONS (mm)

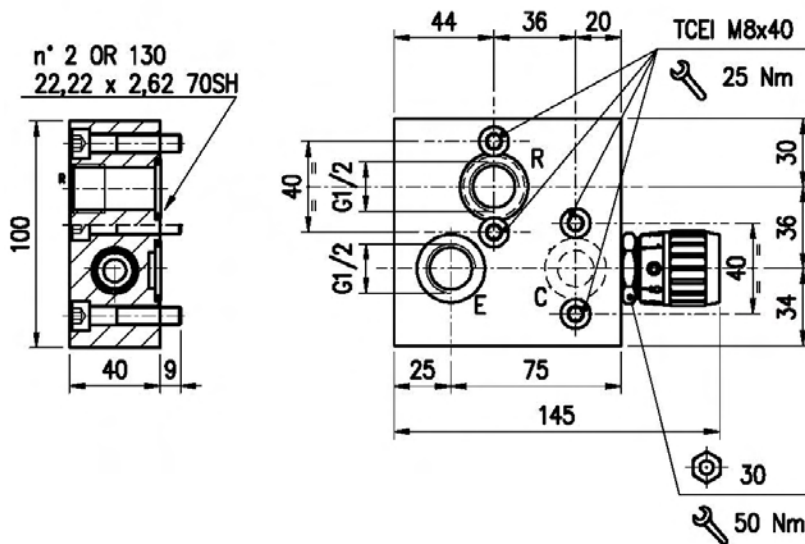

• HYDRAULIC DIAGRAM

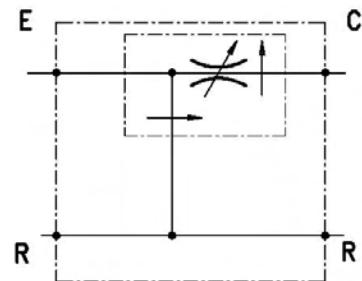

• ASSEMBLY DIAGRAM

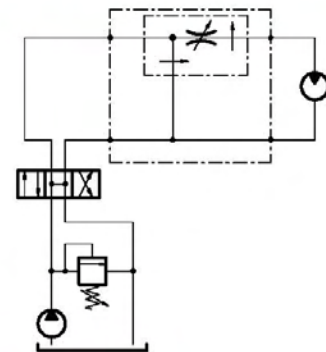

• DESCRIPTION

3-way flow regulators, pressure compensated, with exceeding flow to pressure, face mounting for Sauer-Danfoss motor OMR Series, including OR and Screws.

• OPERATION

These valves are designed for oil flow adjustment in C and exceeding flow in R to pressure for other different applications. To assure top performance, 10% higher flow should be available in E more than in C. The oil flow in C doesn't change when pressure in C and R increases/decreases. Make sure that a pressure relief valve is always mounted between the pump and the flow regulator.

• PERFORMANCE

Maximum flow: 50 l/min in E and 30 l/min in C

Maximum Pressure:

– Aluminium body: 210 bar

– Steel body: 350 bar

Maximum pressure compensation error: see performance graph.

Working temperature:

– Minimum -25°C max 90°C with standard BUNAN gaskets

– Minimum -20°C max 120°C with optional VITON gaskets

Spare parts KIT:

– screws and seals (ordering code: 5KTM00MR01)

– external seals (ordering code: 5KT0103000)

• RECOMMENDATIONS

Fluid: best use mineral oil with viscosity ranging between 10 and 200 cSt

Filter: see page Z.9000.000.

Installation: make sure to provide suitable gasket lubrication with clean oil before screwing the

• CROSS SECTION

Cartridge Type: PP10A/AM0B
see page: K.5000.200

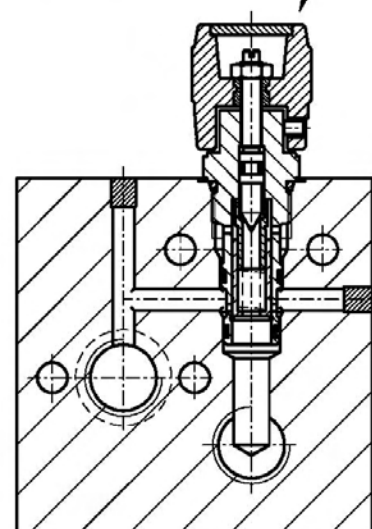

cartridge on the valve body. Also make sure to screw the cartridge manually in to reach against the gaskets in the valve body.

Weight:

- Alluminium body: 1,1kg
- Steel body: 2,2 kg

Cartridge used: consult our Technical Department.

Material: high-grade steel duly treated and fabricated.

For more information please ask our Technical Department.

Variations and modifications of technical features and dimensions are reserved. **HANSA-TMP s.r.l.** also reserves the right to stop production of each and any model listed in the catalogue with no notice.

Copyrights on the text contained herein belong to **HANSA-TMP s.r.l.**. Partial and full reproductions or copies of this catalogue are forbidden.

• RATING DIAGRAMS

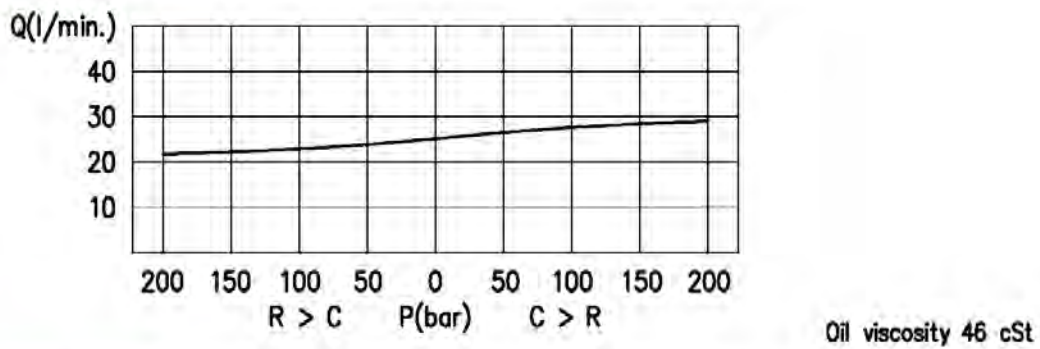

• ADJUSTMENTS

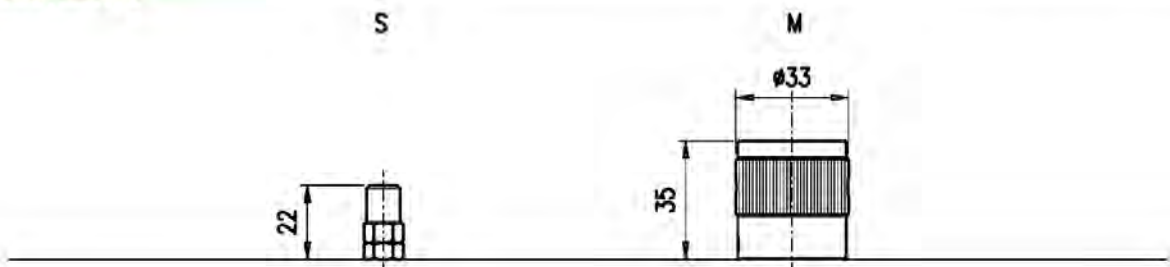

• CODE NUMBER

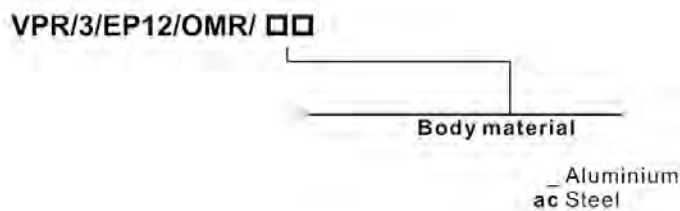

• DIMENSIONS (mm)

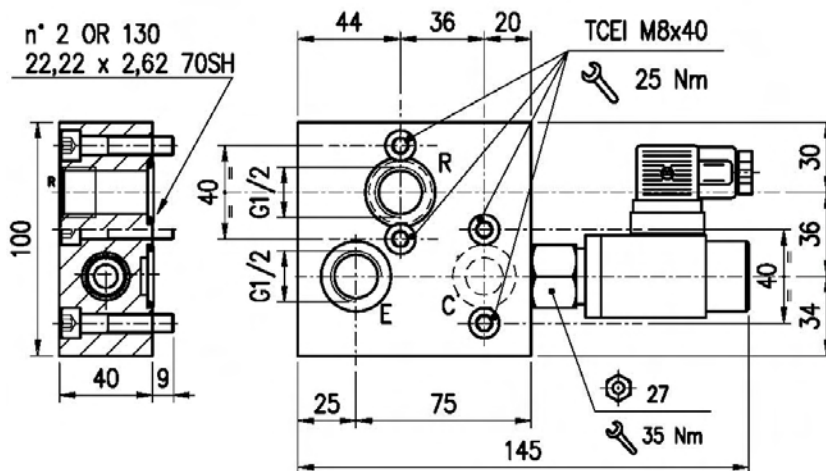

• HYDRAULIC DIAGRAM

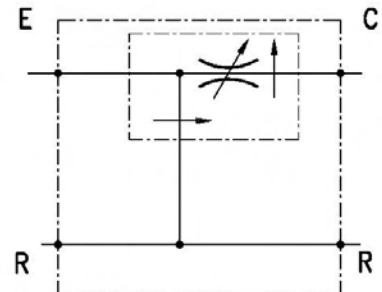

• ASSEMBLY DIAGRAM

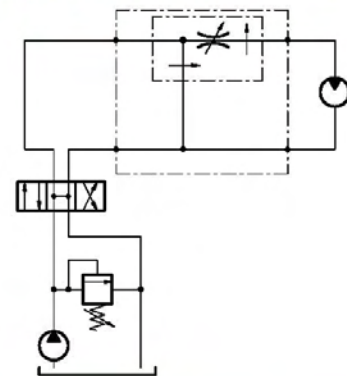

• DESCRIPTION

3-ways proportional flow regulator, pressure compensated and exceeding flow to pressure, face mounting for Sauer-Danfoss motor OMR Series, including OR and Screws.

• OPERATION

The valve is designed to keep constant flow in C and concurrently discharge in R exceeding flow for other applications. Best performance of the valve is assured when the flow in E is at least 10% bigger than in C. Pressure variations in C and R do not alter the constant flow in C. Make sure that a pressure relief valve is always used between the pump and the valve.

• PERFORMANCE

Maximum flow: 30 l/min.

Maximum Pressure:

- aluminium body 210 bar
- steel body 350 bar

Maximum pressure compensation error: see performance graphs.

Working temperature:

- Minimum -25°C max 90°C with standard BUNAN gaskets
- Minimum -20°C max 120°C with VITON gaskets on request

Spare parts KIT:

- screws and seals (Ordering code: 5KTM00MR01)
- external seals PP10W (ordering code: 5KT0103000)

• RECOMMANDATIONS

Fluid: best use mineral oil with viscosity ranging between 10 and 200 cSt

• CROSS SECTION

Cartridge Type: PP10W/A20B

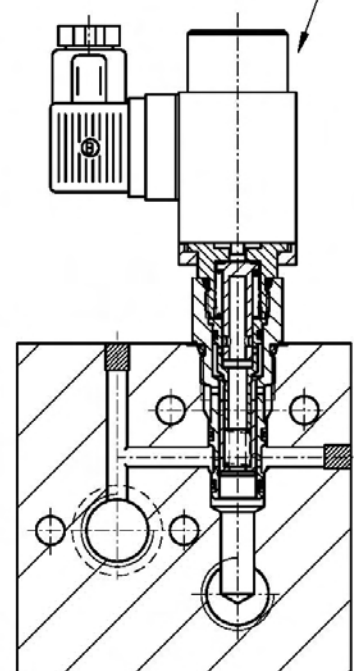

Filter: see General Informations.

Weight:

- aluminium body 1,3 kg
- steel body 2,6 kg

Material: internal components made out of high-grade steel duly treated and fabricated.

For more information please ask our Technical Department.

Variations and modifications of technical features and dimensions are reserved. **HANSA-TMP s.r.l.** also reserves the right to stop production of each and any model listed in the catalogue with no notice.

Copyrights on the text contained herein belong to **HANSA-TMP s.r.l.**. Partial and full reproductions or copies of this catalogue are forbidden.

• RATING DIAGRAMS

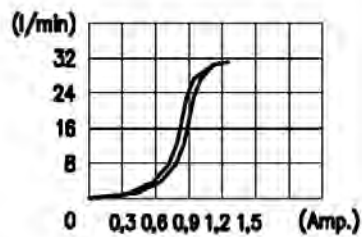

Oil viscosity 46 cSt

• CODE NUMBER

VPR/3/EP12/OMR/CEP □□ / □□

Voltage (Volt)

- 12 Vcc
- 24 Vcc

Body material

- Aluminium
- ac Steel

• DIMENSIONS (mm)

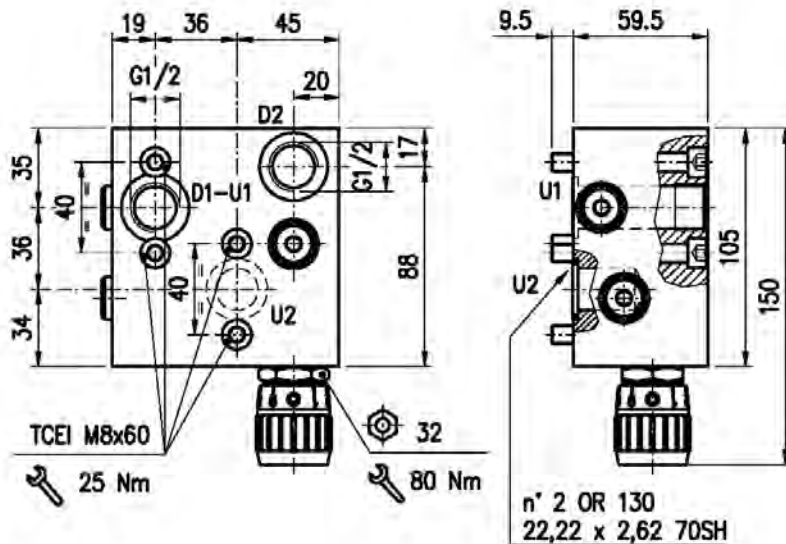

• HYDRAULIC DIAGRAM

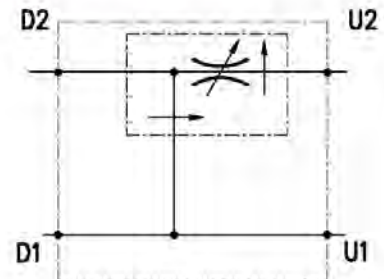

• ASSEMBLY DIAGRAM

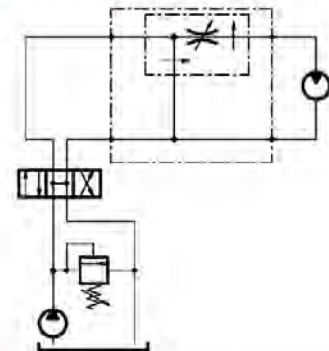

• DESCRIPTION

3-way flow regulators, pressure compensated, with exceeding flow to pressure, face mounting for Sauer-Danfoss motor OMR Series, including OR and Screws.

• OPERATION

These valves are designed for oil flow adjustment in U2 and exceeding flow in D1-U1 to pressure for other different applications. To assure top performance, 10% higher flow should be available in D2 more than in U2. The oil flow in U2 doesn't change when pressure in U2 and D1-U1 increases/decreases. Make sure that a pressure relief valve is always mounted between the pump and the flow regulator.

• PERFORMANCE

Maximum flow: 90 l/min in D2 and 50 l/min in U2

Maximum Pressure:

- Aluminium body: 210 bar
- Steel body: 350 bar

Maximum pressure compensation error: see performance graph.

Working temperature:

- Minimum -25°C max 90°C with standard BUNAN gaskets
- Minimum -20°C max 120°C with optional VITON gaskets

Spare parts KIT:

- screws and seals (ordering code: 5KTM00MR02)
- external seals PP12A (ordering code: 5KT0123000)

• CROSS SECTION

Cartridge Type: PP12A/AM0B
see page: K.5000.300

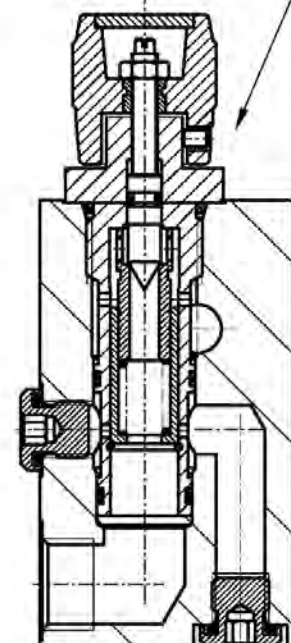

• RECOMMENDATIONS

Fluid: best use mineral oil with viscosity ranging between 10 and 200 cSt

Filter: see General Informations.

Installation: make sure to provide suitable gasket lubrication with clean oil before screwing the cartridge on the valve body. Also make sure to screw the cartridge manually in to reach against the gaskets in the valve body.

Weight:

- Alluminium body: 1,2kg

- Steel body: 2,4 kg

Cartridge used: consult our Technical Department.

Material: high-grade steel duly treated and fabricated.

For more information please ask our Technical Department.

Variations and modifications of technical features and dimensions are reserved. HANSA-TMP s.r.l. also reserves the right to stop production of each and any model listed in the catalogue with no notice.

Copyrights on the text contained herein belong to HANSA-TMP s.r.l.. Partial and full reproductions or copies of this catalogue are forbidden.

• RATING DIAGRAMS

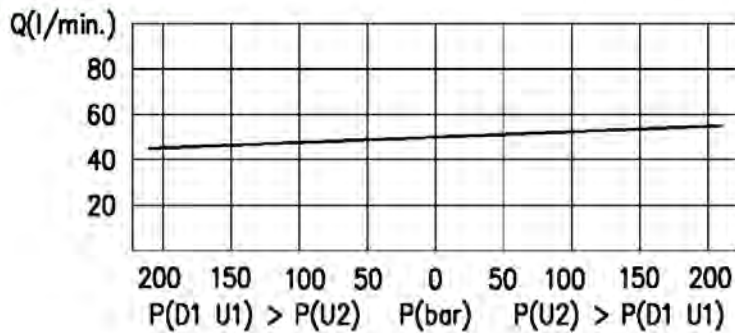

Oil viscosity 46 cSt

• CODE NUMBER

VPR/3/EP/12/OMR/VG/ □□

Body material

Aluminium
 ac Steel

• DIMENSIONS (mm)

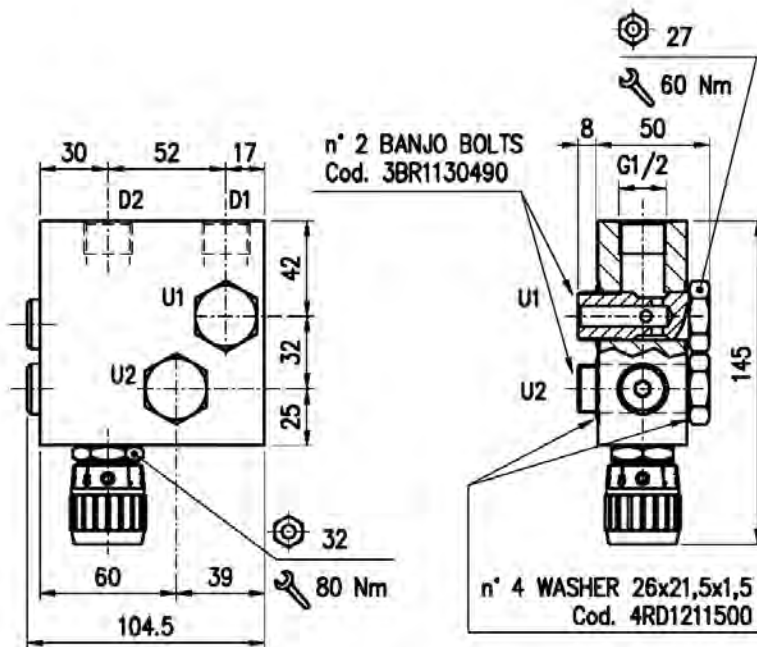

• HYDRAULIC DIAGRAM

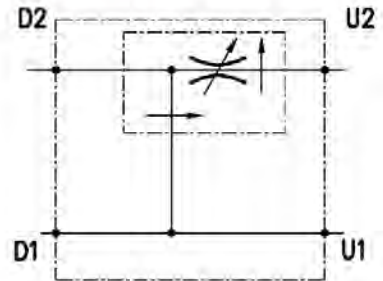

• ASSEMBLY DIAGRAM

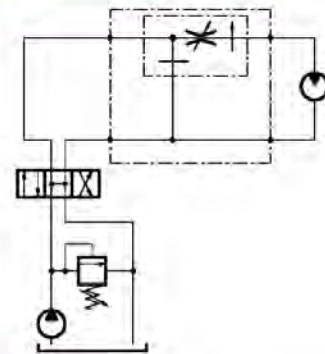

• DESCRIPTION

3-way flow regulators, pressure compensated, with exceeding flow to pressure, face mounting for Sauer-Danfoss motor OMS Series, including OR and Screws.

• OPERATION

These valves are designed for oil flow adjustment in U2 and exceeding flow in D1-U1 to pressure for other different applications. To assure top performance, 10% higher flow should be available in D2 more than in U2. The oil flow in U2 doesn't change when pressure in U2 and D1-U1 increases/decreases. Make sure that a pressure relief valve is always mounted between the pump and the flow regulator.

• PERFORMANCE

Maximum flow: 90 l/min in D2 and 50 l/min in U2

Maximum Pressure:

- Aluminium body: 210 bar
- Steel body: 350 bar

Maximum pressure compensation error: see performance graph.

Working temperature:

- Minimum -25°C max 90°C with standard BUNAN gaskets
- Minimum -20°C max 120°C with optional VITON gaskets

Spare parts KIT:

- banjo bolt (Ordering code: 3BR1130490)
- external seals PP12A (ordering code: 5KT0123000)

• RECOMMENDATIONS

Fluid: best use mineral oil with viscosity ranging between 10 and 200 cSt

Filter: see page Z.9000.000.

• CROSS SECTION

Cartridge Type: PP12A/AMOB
see page: K.5000.300

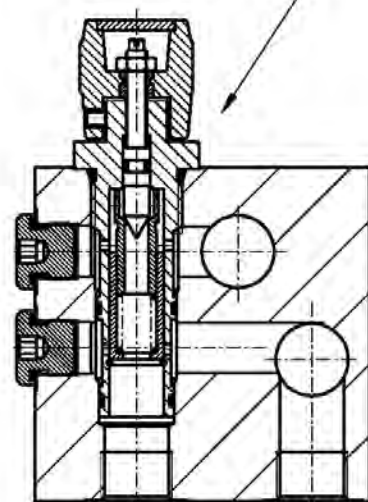

Installation: make sure to provide suitable gasket lubrication with clean oil before screwing the cartridge on the valve body. Also make sure to screw

the cartridge manually in to reach against the gaskets in the valve body.

Weight:

- Aluminium body: 1,1 kg
- Steel body: 2,2 kg

Cartridge used: consult our Technical Department.

Material: high-grade steel duly treated and fabricated.

For more information please ask our Technical Department.

Variations and modifications of technical features and dimensions are reserved. HANSA-TMP s.r.l. also reserves the right to stop production of each and any model listed in the catalogue with no notice.

• RATING DIAGRAMS

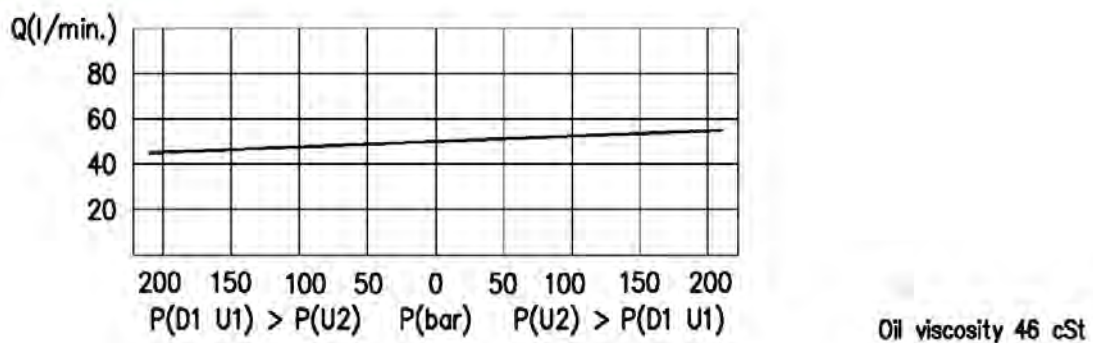

• CODE NUMBER

VPR /3/ EP 12/OMS / □□

Body material

- _ Aluminium
- ac Steel

As HANSA-TMP has a very extensive range of products and some products have a variety of applications, the information supplied may often only apply to specific situations.

If the catalogue does not supply all the information required, please contact HANSA-TMP.

In order to provide a comprehensive reply to queries we may require specific data regarding the proposed application.

Whilst every reasonable endeavour has been made to ensure accuracy, this publication cannot be considered to represent part of any contract, whether expressed or implied.

HANSA-TMP reserves the right to amend specifications at their discretion.



HYDRAULIC COMPONENTS
HYDROSTATIC TRANSMISSIONS
GEARBOXES - ACCESSORIES

Via M. L. King, 6 - **41122 MODENA (ITALY)**
Tel: +39 059 415 711
Fax: +39 059 415 729 / 059 415 730
INTERNET: <http://www.hansatmp.it>
E-MAIL: hansatmp@hansatmp.it