

HT 130 / A / 109 / 0108 / E

Variable Displacement Open Loop Circuit Axial Piston Pumps

AR Series



Contents

Installation - General Information	4
Features & Technical Characteristics	5
Order Code	6
Control Type	7 - 8
Technical Specifications	9
Installation Drawing	10 - 12

Installation - General Information

1 - Fluid recommendations

Premium quality hydraulic mineral oil fluids are recommended, like H-LP oils to DIN 51542 part 2. The oil viscosity range should be from 25 mm²/s to 50 mm²/s. Operating temperature from -10° C to 70° C are recommended. For other fluids such as phosphoric acid esters or for other operating conditions please consult our Tech.Dpt.

2 - Seals

NB (Nitrile) seals are used for operation with hydraulic fluids based on mineral oil. For synthetic, as perhaps phosphoric acid ester, Fluorocarbon seals are required. For any assistance please consult our Tech.Dpt.

3 - Filtration

Contamination of the hydraulic oil may cause trouble with the pump and shorten its life. For maximum pump and system component functionality and life, the system should be protected from contamination by effective filtration. Fluid cleanliness should be in accordance with classification ISO 4406. The quality of filter elements should be in accordance with ISO standards.

Minimum requirement for filtration rate:

General hydraulic system for satisfactory operation: Class 19/17/14 to ISO 4406 (Class 9 NAS 1638)

Hydraulic system with maximized component life and reliability: Class 17/15/12 to ISO 4406 (Class 7 NAS 1638)

It is recommended to use return or pressure line filter, a wide range of filters for all common application are available.

The use of suction filter should be avoided, especially with fast response pump.

Off-line filtration is a good choice for the best filtering efficiency.

4 - Installation and mounting

Horizontal mounting: Outlet port, side or top; Inlet port, side or bottom; Drain port always uppermost.

Vertical mounting: Drive shaft vertically upward.

Install pump and suction line in such a way that the maximum inlet vacuum never exceeds 0,8 bar absolute.

The inlet line should be as short and straight as possible.

A short suction line cut to 45° is recommended when the pump is mounted inside the reservoir, to improve the inlet conditions.

All connections to be leadfree, as air in the suction line will cause cavitation, noise and damage the pump.

5 - Allignment and installation

Pump and motor shaft must be aligned within 0,25 mm. T.I.R max. A floating coupling must be used.

Please follow the coupling manufacturer's installation instruction. Consult our Tech.Dpt. in event of radial load drives.

6 - Start-up

Prior to start-up, the pump case must be filled with clean system hydraulic fluid (use case drain port).

Do not operate the pump at full speed right away. Instead, turn the motor input switch on - off several times so as to extract air from the piping, then operate it continuously.

Initial start-up should be at zero pressure with an unloaded circuit to enable the pump to prime.

Pressure should only be increased once the pump has been fully primed.

Attention: Check the motor rotation direction.

Operating noise of pumps

The normal operating noise of a pump and consequently the operating noise of the entire hydraulic system is largely determined by where and how the pump is mounted and connected to the hydraulic system.

Also size, style and installation of the hydraulic tubing have a major influence on the overall noise emitted by a hydraulic system.

Noise reducing measures

Flexible element help to prevent pump body vibration being transmitted to other construction elements, where possible amplification may occur. Such element can be:

- 1 - Floating and flexible coupling.
- 2 - Damping rails.
- 3 - Or silent block for mounting the electric motor or the foot mounting flange.
- 4 - Flexible tube connections (compensator) or hoses for inlet, outlet and drain port.
- 5 - Exclusive use of gas tight tube fittings for inlet connection to avoid air entry causing cavitation and excessive noise.

7 - Drain line

The case pressure must not exceed 0,04 MPa (0,36 bar).

The drain line must be connected directly to the reservoir without restriction and must not be connected to any other return line. The end of the drain line must be below the lowest fluid level in the reservoir and as far-away as possible from the pump input line to ensure that the pump does not empty itself when not in operation and that the hot oil will not recirculated.

For the same reason, when the pump is mounted inside the reservoir, the drain line should be arranged in such a way that a siphon is created. For drain line size and length refer to the table below.

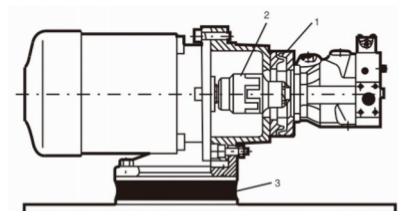

Pump model	AR 16 - AR 22
Pipe joint size	3/8"
Pipes internal diam.	> 12 mm.
Pipes lenght	< 1 m.

AR Series AXIAL PISTON PUMP

FEATURES

For the control section, a unique cartridge structure is incorporated.

The internal sliding surfaces, made of a wear resistant, seizure proof material, have been surfaced treated.

As the main internal parts, such as the cylinder blocks and piston assemblies are used, are similar to V Series pumps, the reliability is well-know and outstanding.

A special designed semi-cylindrical swash plate bearing structure, effectively reduces vibrations and noise, whilst being more compact.

The housing is a compact and light mass design => 9,4 kg.

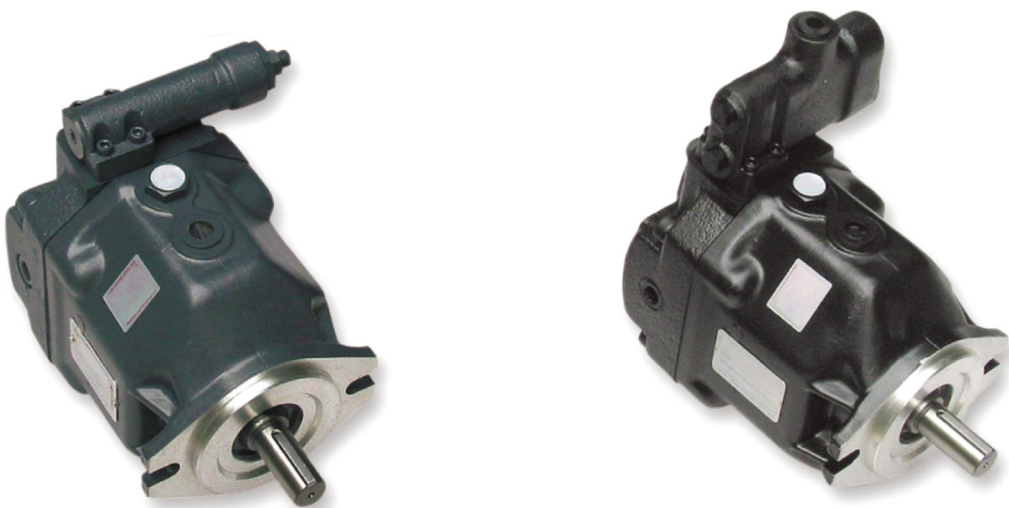

Technical Characteristics

Pump model	Displacement cm ³ /n	Rated pressure bar	Peak pressure bar	Delivery under unloading conditions lt/min.		Input Speed range n/min.		Weight kg
				1.500 n/min.	1.800 n/min.	min.	max.	
AR 16	15,8	165	210	23,10	28,44	50	1.800	9,4
AR 22	22,2			33,30	39,96			

AR Series AXIAL PISTON PUMP ORDER CODE

AR 16 F R 01 C S K 10 Y

Pump Series AR

Max. Displacement:

16 = 15,8 cm³/n
22 = 22,2 cm³/n

Pump Mounting:

F - Flange mounting

Shaft Rotation (view from shaft end):

R - Clockwise rotation (Right) (Standard)
L - Counter Clockwise rotation (Left)

Pump Control Type (see pages 14-17):

- 01 - Pressure Compensator Control (See type A)
- G - Remote Pressure Compensator Control
- GJ - Layer Proportional Pressure Compensator
- GR - Electrical Unloading (See type D)
- GB - Dual Pressure Control (See type E)
- GC - Dual Pressure Control + Electrical Unloading
- GM - Remote Press. Comp. Control Allows a Pilot Valve
- HL - Load-sensing Compensator

Design Number:

X
Y (Standard)

Threads Code:

10 = PT (Pipe type)
40 = BSPP (G)
50 = NPT

Mounting Shaft and Type:

K = Keyed
G = Splined SAE J 498 b - Z 13 -16/32 DP
T = Splined SAE J 498 b - Z 9 -16/32 DP

Direction of Pipe Connection:

none - Axial port (Standard)
S - Side port



Compensator Pressure setting:

B - 12 - 70 1,2 - 7 MPa (12-70 bar)
C - 12 - 210 1,2 - 21 MPa (12-210 bar)

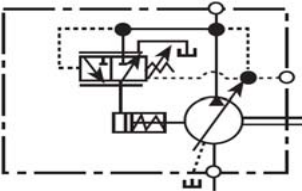
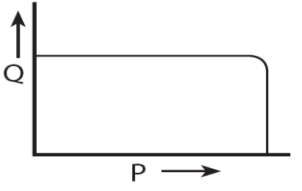
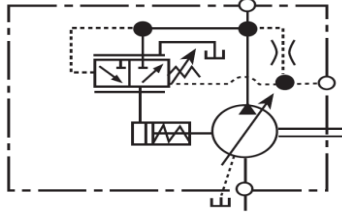
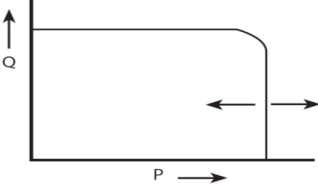
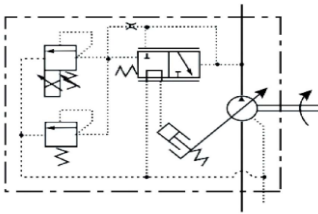
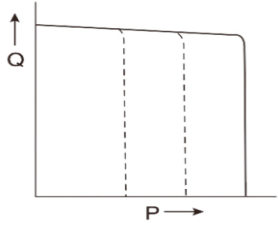
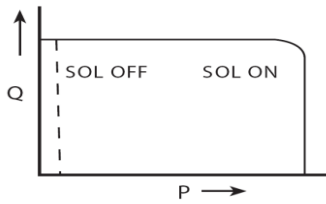
FUNCTIONAL DESCRIPTION OF REGULATOR

Control Type	Hydraulic Symbol	Control Curve
<p>01 - Pressure compensator control 1 - When system pressure increase and reach preset pressure the flow decrease automatically and pressure maintain without changing. 2 - Flow and pressure can be adjusted manually.</p>		
<p>G - Remote pressure compensator control 1 - The same function of "A" control type. 2 - The pressure range can be adjusted remotely by the integrated remote pressure control valve.</p>		
<p>GJ - Proportional pressure with interface 1 - The same function of "GM" control type and proportional valve added. 2 - The proportional valve is installed on the NG 6 interface to reach proportional electro-hydraulic control to save energy.</p>		
<p>GR - Electric unloading device 1 - Same as Type "A" and unloading function added. 2 - It is applied to systems requiring long time unloading operation. 3 - When solenoid is turned off, the pump operates under unloading conditions. This results in less noise and heat generation.</p>		

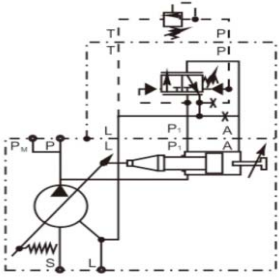
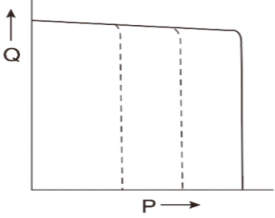
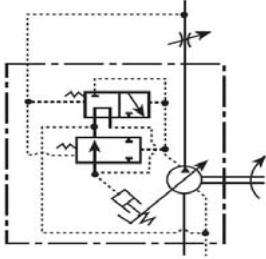
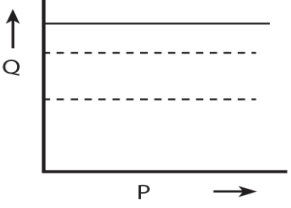
FUNCTIONAL DESCRIPTION OF REGULATOR

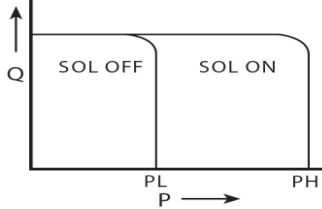
Control Type	Hydraulic Symbol	Control Curve
<p>GM - Remote interface (valve not included)</p> <p>1 - GM control with a NG6 interface, supply an installation for pilot valve to prove the operating pressure. The pressure setting can be set directly from the control panel of the machine.</p> <p>2 - The remote pressure compensator responds faster and offer more stable pressure.</p> <p>3 - The adjustment can also be manual or proportional pressure control.</p>		
<p>HL - Load sensing compensator control</p> <p>1 - The pump outlet can be controlled by the setting pressure value of control valve. An ideal energy conservation system can be configured by combining the proportional directional control.</p> <p>2 - When setting pressure value, flow is changed depending on the throttle valve. The sensing flow feedback function can reach to low oil heat generation and saving energy.</p>		
<p>GB - Dual pressure control</p> <p>1 - High and low pressure can be controlled by switching directions of solenoid control valve.</p> <p>2 - This type is applied to actuators requiring 2-stage pressures with single speed.</p> <p>3 - One of "PL" and "PH" relief valves can optionally be high pressure.</p>		

AR Series Axial Piston Pump - Technical Specifications

Typical performance characteristics

- Input speed: 1800 n/min.
- Oil ISO: VG 32
- Oil temperature: 50°C

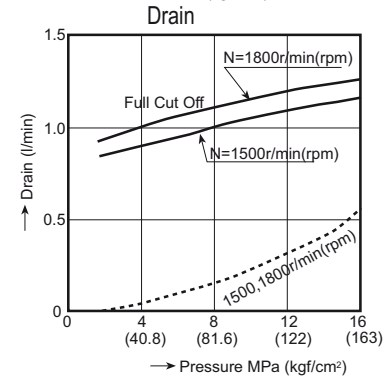
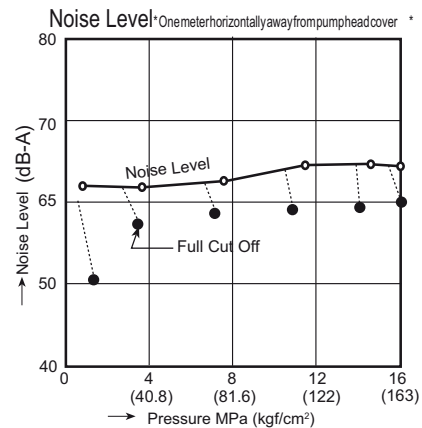
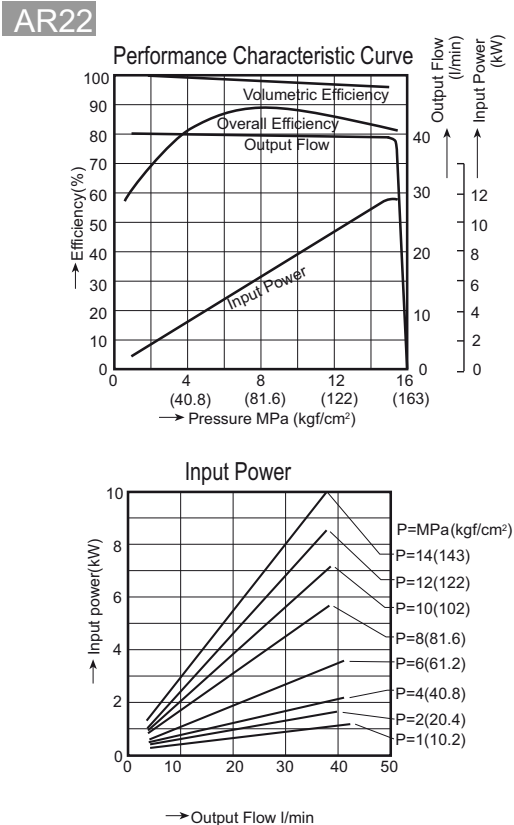
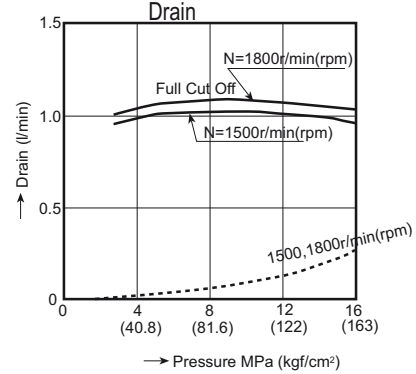
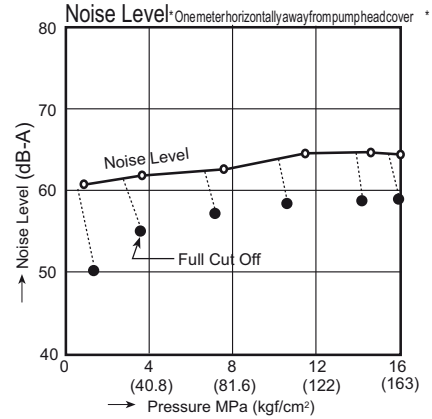
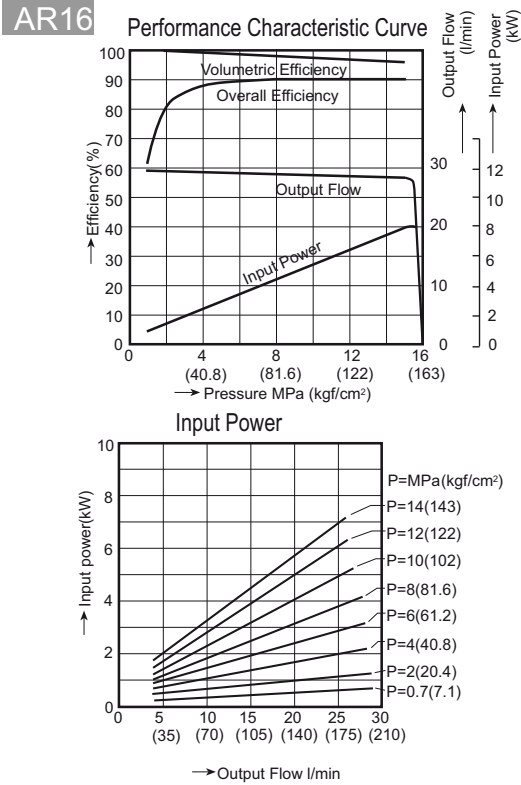

AR Series Axial Piston Pump Installation Drawing (SAE "A" 2 bolt)

AR 16 01 - AR 22 01

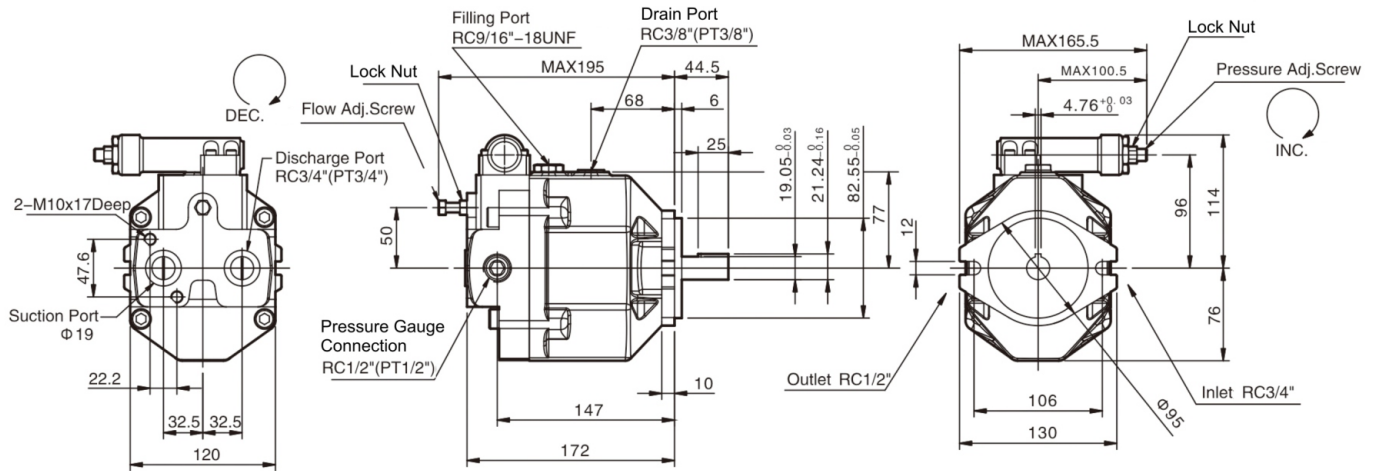

AR 16 G - AR 22 G

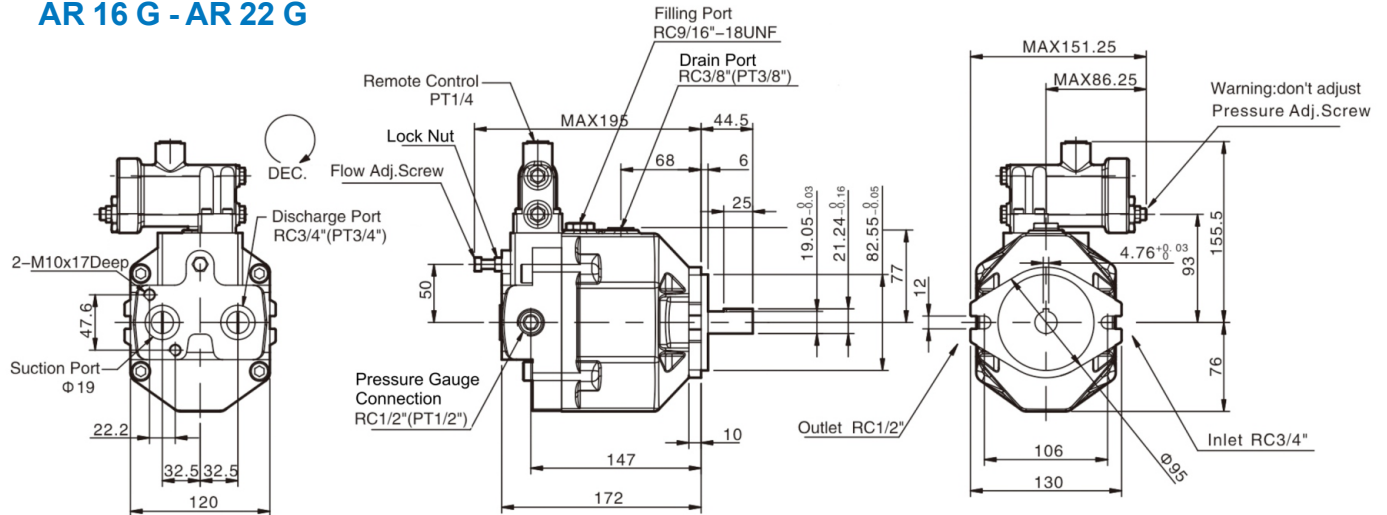

AR 16 HL - AR 22 HL

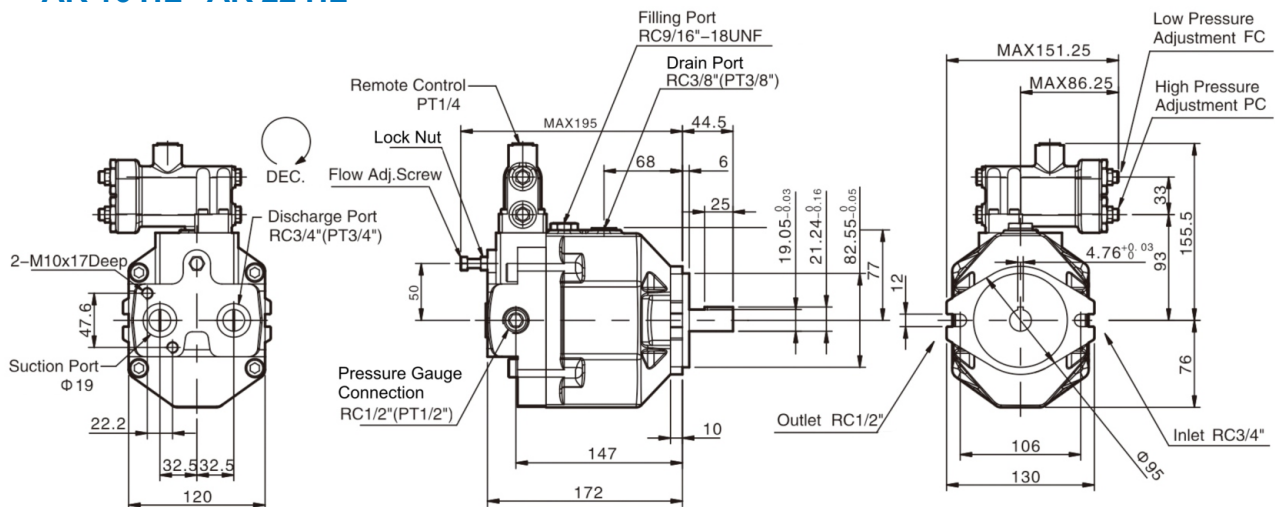

Note: - Inlet - Outlet port are for standard rotation (clockwise)



AR Series Axial Piston Pump Installation Drawing (SAE "A" 2 bolt)

AR 16 GJ - AR 22 GJ

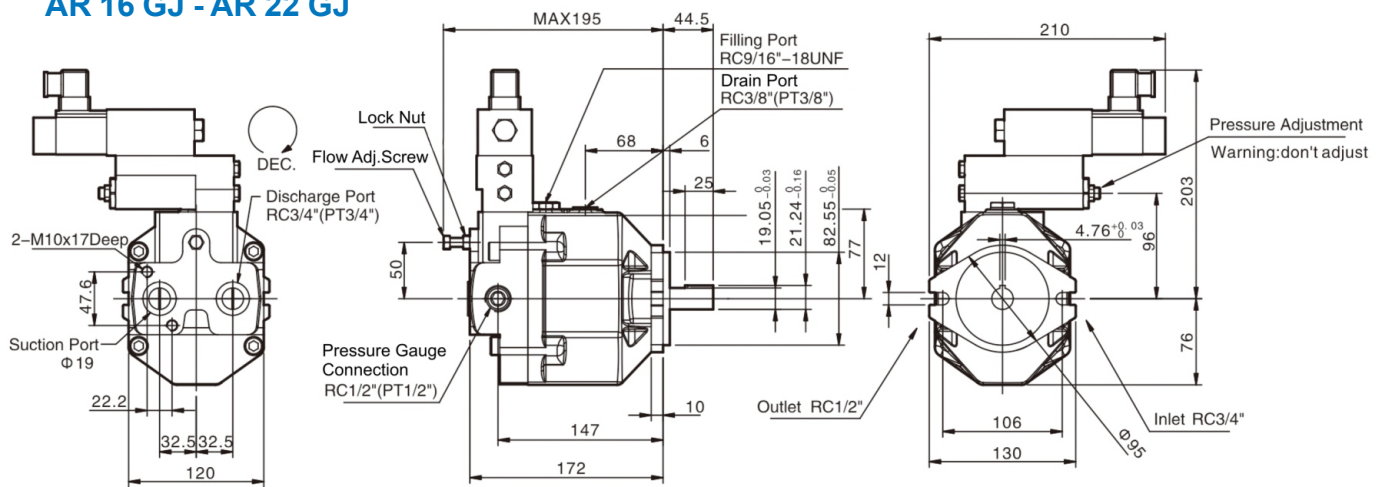

AR 16 GR - AR 22 GR

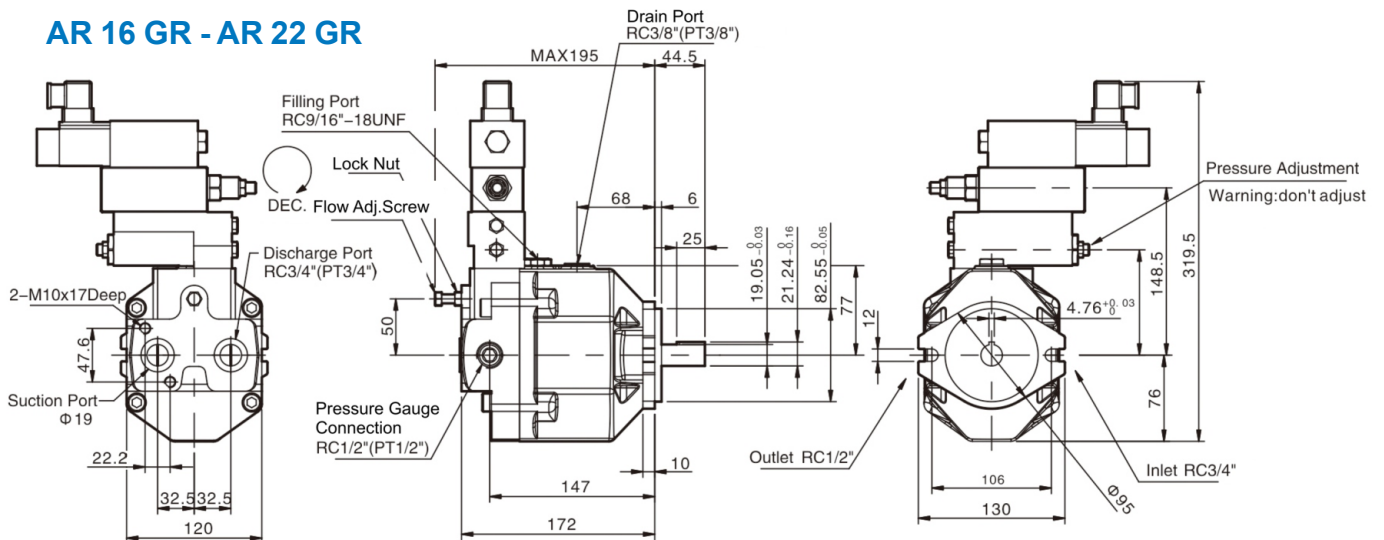

AR 16 GB - AR 22 GB

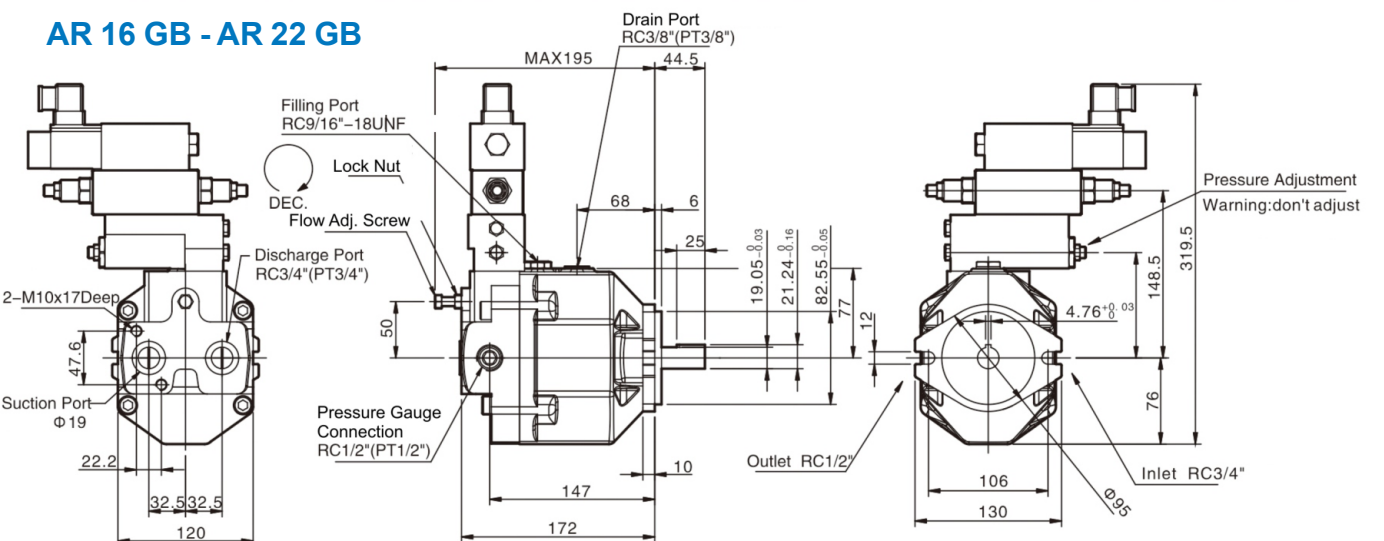

Note: - Inlet - Outlet port are for standard rotation (clockwise)

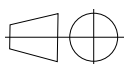

AR Series Axial Piston Pump Installation Drawing (SAE "A" 2 bolt)

AR 16 GC - AR 22 GC

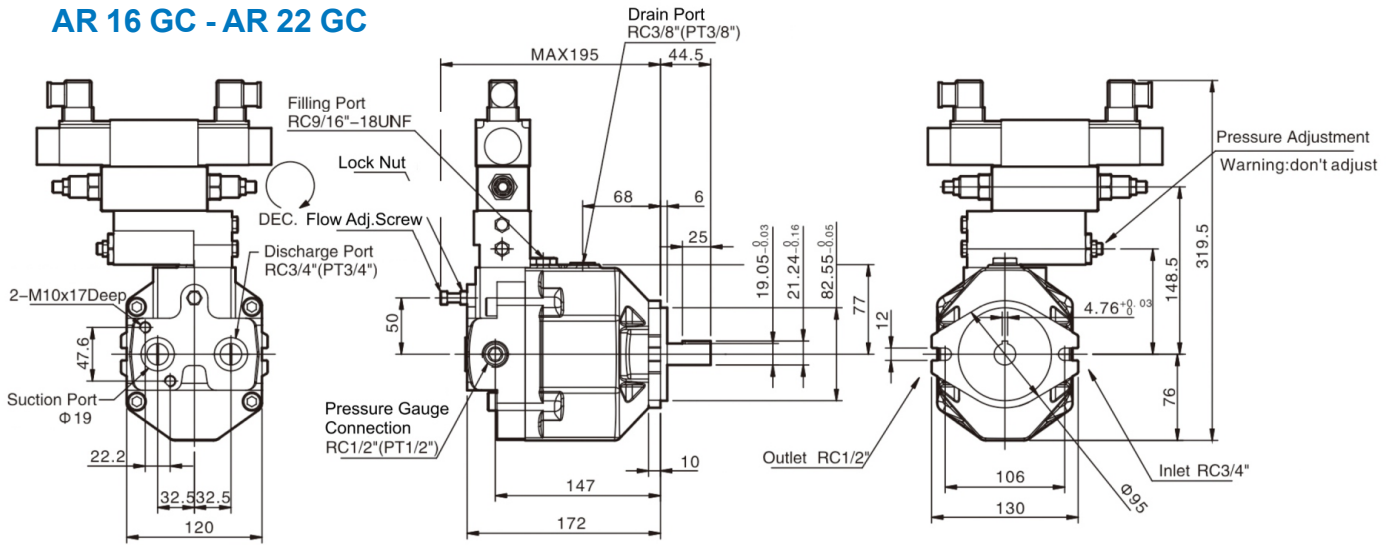

AR 16 GM - AR 22 GM

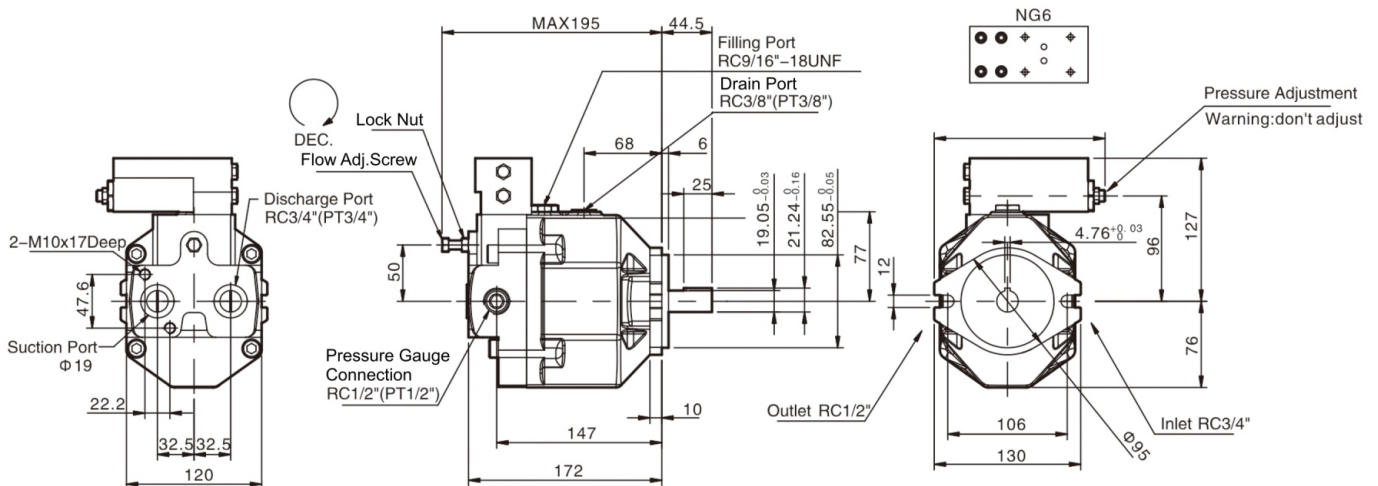

AR 16 - AR 22 Splined Shaft

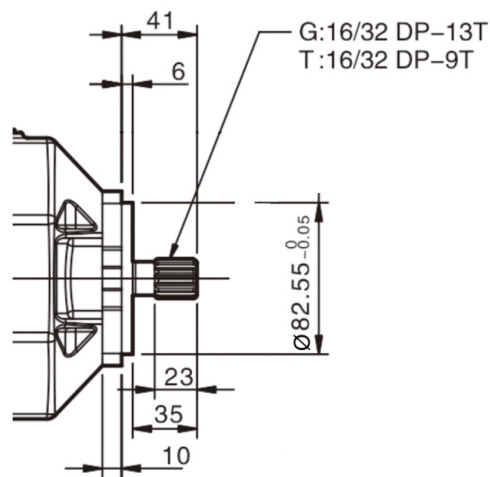

Note: - Inlet - Outlet port are for standard rotation (clockwise)



As HANSA-TMP has a very extensive range of products and some products have a variety of applications, the information supplied may often only apply to specific situations. If the catalogue does not supply all the information required, please contact HANSA-TMP.

In order to provide a comprehensive reply to queries we may require specific data regarding the proposed application.

Whilst every reasonable endeavour has been made to ensure accuracy this publication cannot be considered to represent part of any contract, whether expressed or implied.

HANSA-TMP reserves the right to amend specifications at their discretion.



HYDRAULIC COMPONENTS
HYDROSTATIC TRANSMISSIONS
GEARBOXES - ACCESSORIES

Via M.L. King, 6 - **41100 MODENA (ITALY)**
Tel: +39 059 415 711
Fax: +39 059 415 729 / 059 415 730
INTERNET: <http://www.hansatmp.it>
E-MAIL: hansatmp@hansatmp.it