

## Fixed Displacement Axial Piston Motor for Open and Closed Loop System

# TMF 300





## CONTENTS

General Information.....	4
Technical Specifications.....	5
Installation Drawings.....	6 - 7
Shaft Details.....	8
Optional.....	9 - 11
Order Code.....	12

## GENERAL INFORMATION

The fixed-displacement axial piston motors TMF 300 with swash plate system may operate in either closed or open circuit.

Proper selection of materials and the use of steel cylinder blocks with inserted bushings guarantee the high performance of the TMF 300 motors, in terms of max. speed and working pressure.

The main features of TMF 300 motors include:

- Exceptionally high power/weight ratio
- Excellent volumetric and mechanical efficiency
- Long life
- Compact design
- Purge valve fitted as optional. (All dimensions remain unchanged).

The very small dimensions allow to fit the motor in restricted room or positions which are difficult with traditional mechanical transmission.

### Installation Instructions

- During the assembly check that the motor is in line and concentric with the drive shaft sleeve to prevent overloading of the shaft bearings.
- Clean carefully all tanks and pipes internally before assembly.
- The pipe internal diameter must be suitable for the max. oil speed through the pipes.
- Fit the motor lower than oil level in tank.
- Heat exchanger must be provided in the machine design, to keep temperature level within the limit of 80°C.

### First Starting

- Before starting fill all the system components with new and filtered oil.
- Verify that the charge pressure is correct.
- Restore the tank oil level.

### Maintenance

To guarantee long life, the motor must work with oil cleaned according ISO 4406 class 18/16/13 (NAS 8) or better.

- First oil change must be made after approximately 500 hours of operations, and then every 2000 hours.
- The filter cartridge must be replaced the first time after 50 hours and then every 500 hours; such time should be reduced when the filter clogging indicator shows that the cartridge is clogged or when the system works in a heavily polluted environment.

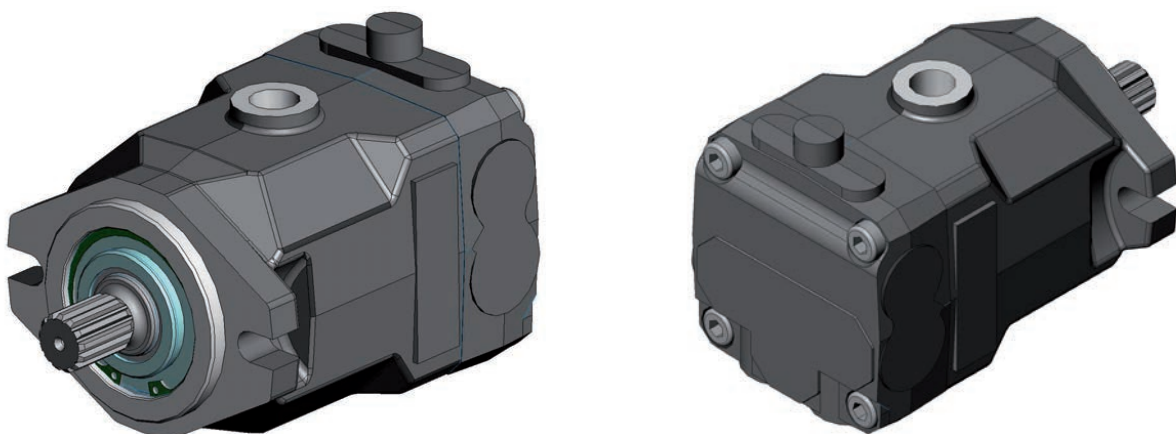

**TECHNICAL SPECIFICATIONS**

<b>Motor Model</b>			<b>TMF 21</b>	<b>TMF 28</b>
Displacement	V	cm <sup>3</sup> /min.	21	28
Theoric specific torque	M	Nm/bar	0,33	0,44
Flow rating <sup>(1)</sup>	Q	l/min.	75,6	100,8
Power rating <sup>(2)</sup>	W	kW	31,8	42
Continuous pressure	P <sub>nom.</sub>	bar		250
Peak pressure	P <sub>max.</sub>	bar		350
Max. case pressure	P <sub>case</sub>	bar		2
Polar moment of inertia	J	Nm/sec <sup>2</sup>	15x10 <sup>-1</sup>	19x10 <sup>-1</sup>
Minimum speed	n <sub>min.</sub>	n/min.		700
Max. cont. speed with load	n <sub>max-cont.</sub>	n/min.		3.600
Max. speed without load	n <sub>max-int.</sub>	n/min.		4.000
Max oil temperature	T	°C		80
Oil viscosity	v	mm <sup>2</sup> /sec.		15 - 60
Fluid contamination			18/16/13 according ISO 4406 (NAS 8)	
Mass	m	kg	7,5	7,8
Mounting flange				SAE A

**Notes:**

(1) [V x n<sub>max.</sub>]

(2) 3.600 n/min. at 250 bar

(3) The motor 21 and 28 use the same external housing

Peak operations must not exceed 1% of every minute.

A simultaneous max. pressure and speed are not recommended.

**INSTALLATION DRAWING**  
**Side Combined A - B Connection**

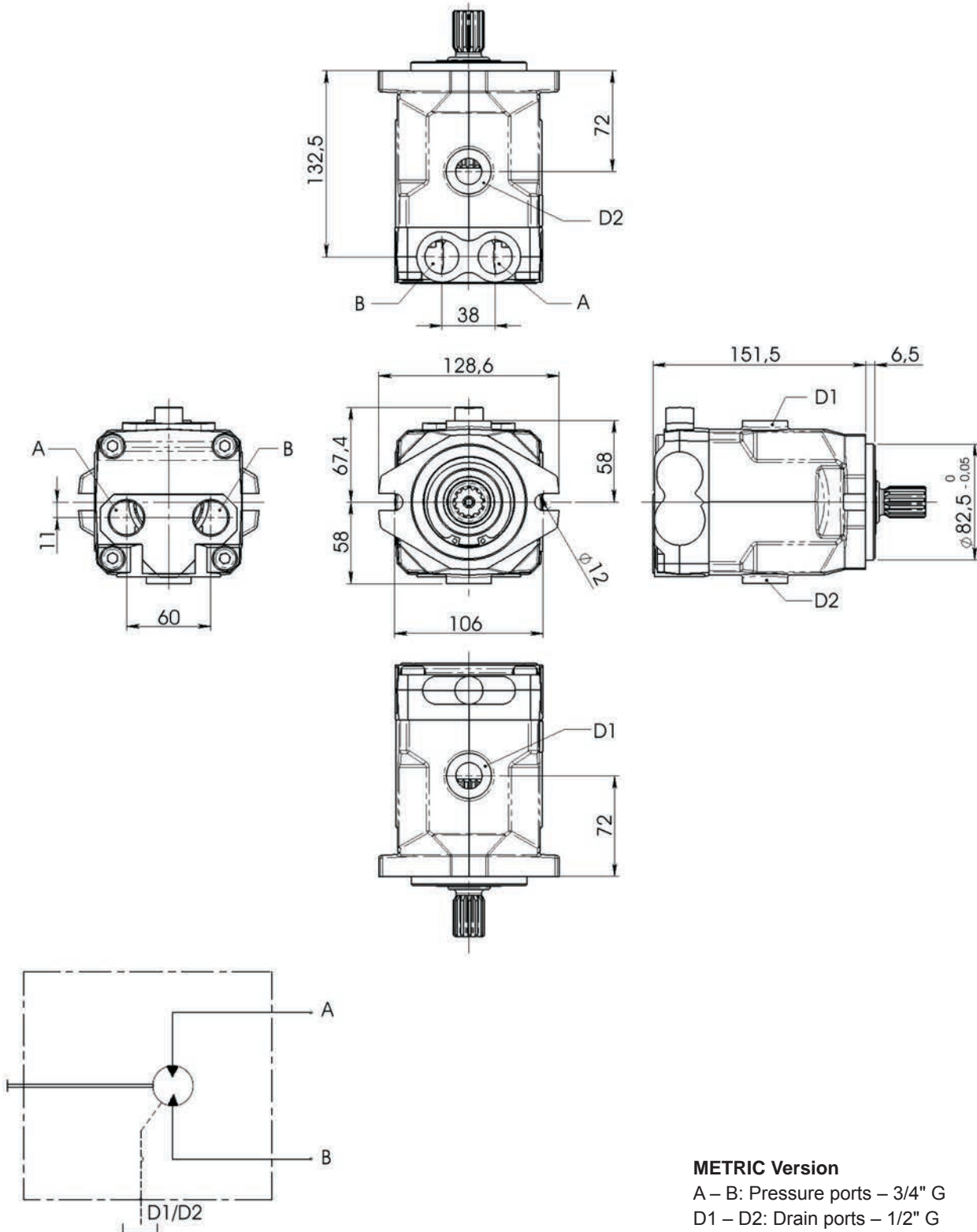

**INSTALLATION DRAWING**  
**Opposite Lateral A - B Connection**

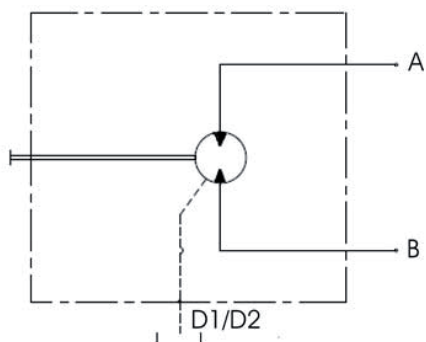
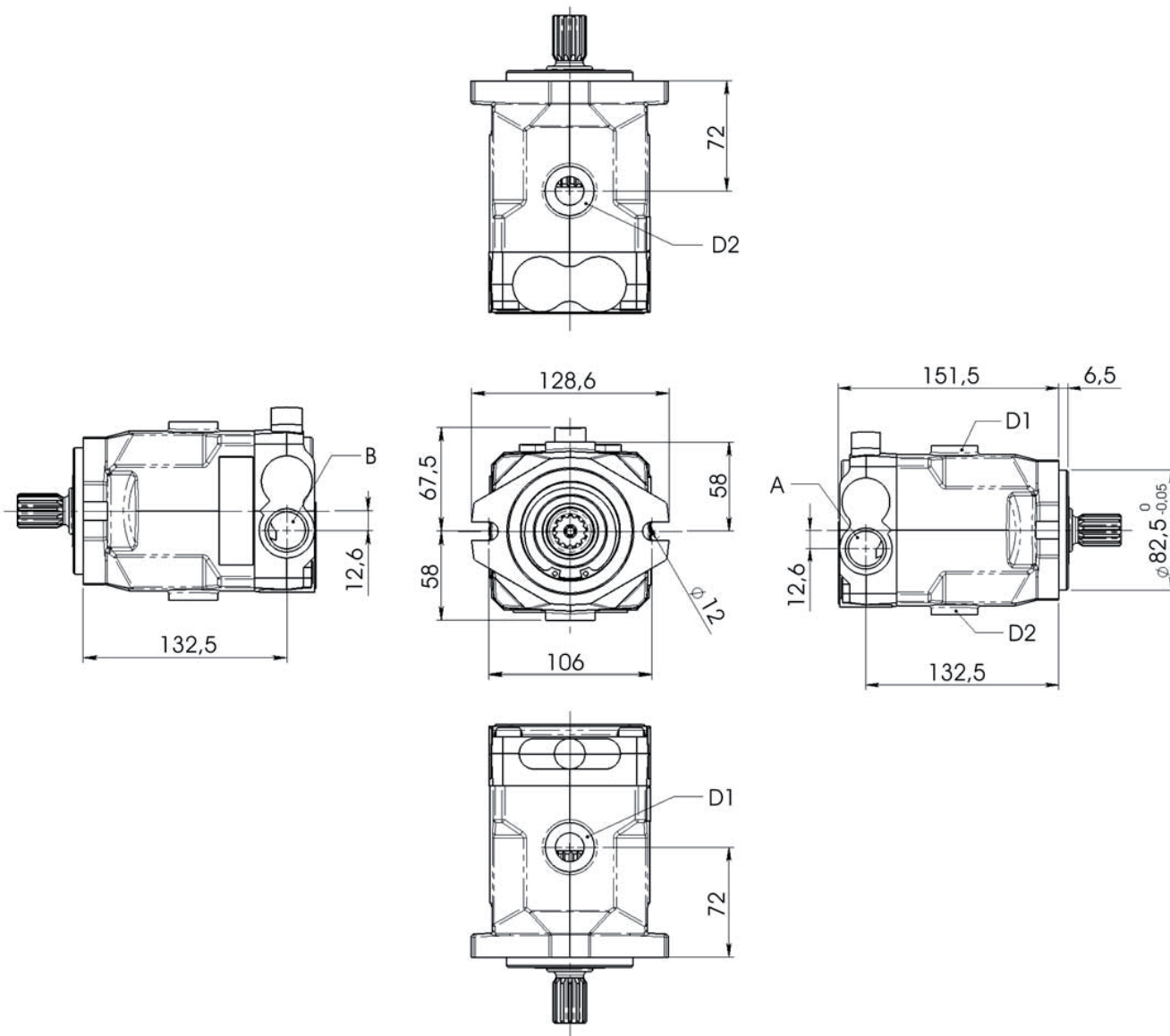

**METRIC Version**

A – B: Pressure ports – 3/4" G  
D1 – D2: Drain ports – 1/2" G

**SHAFTS**

**Type 1 - Parallel diam. 22,22**

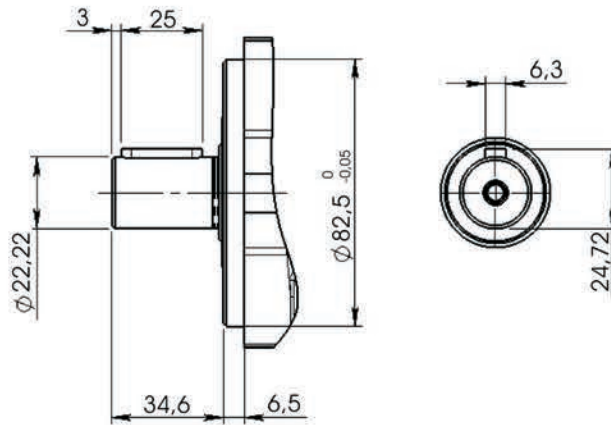

**Type 2 - Parallel diam. 25,4**

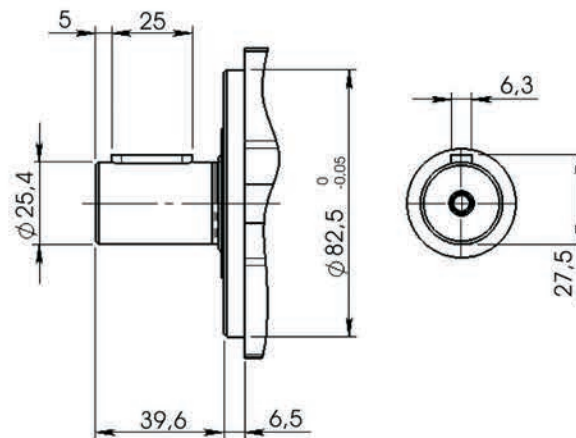

**Type 5 - Splined Male 13T DP 16/32**

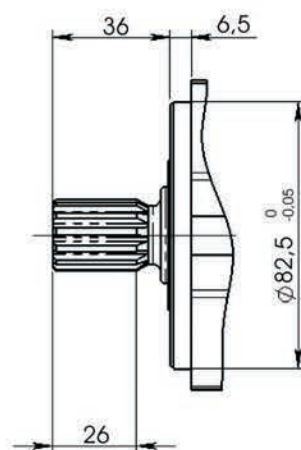



ACCESSORIES  
Rear Drain

P

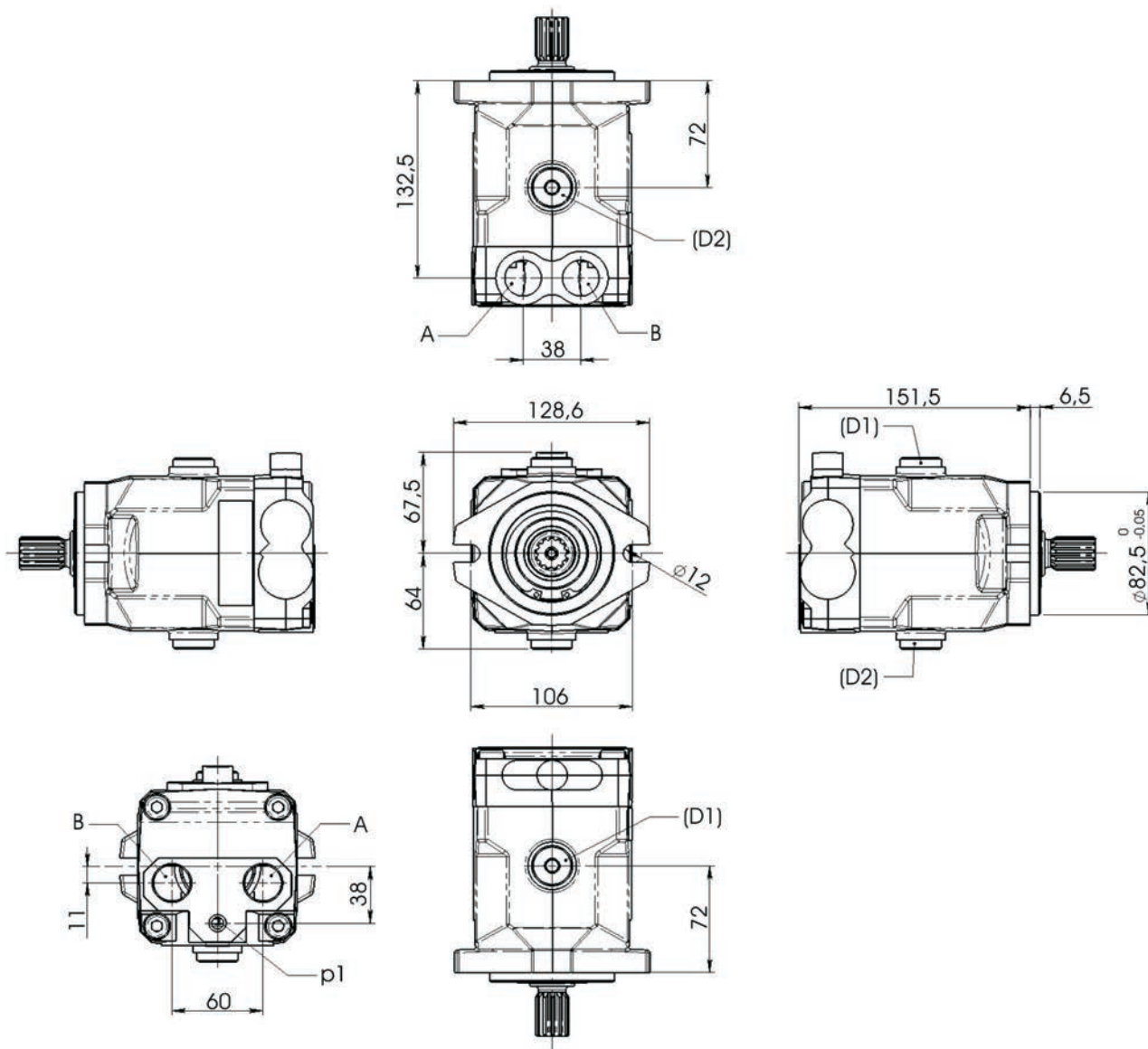

**METRIC Version**

A – B: Pressure ports – 3/4" G

D1 – D2: Drain ports – 1/2" G

p1: Rear drain – 1/4" G

**ACCESSORIES** (continued)  
**Purge Valve**

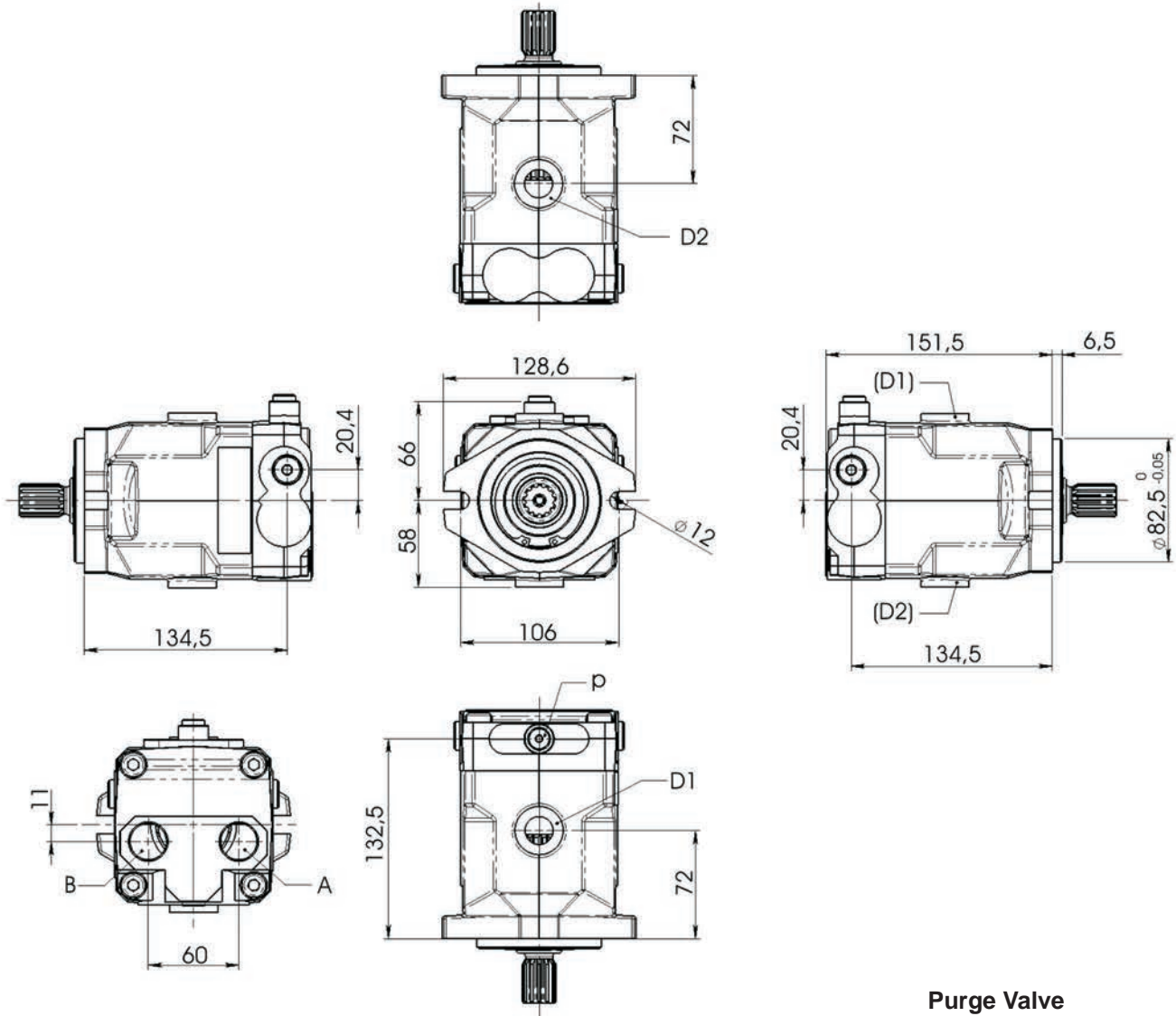

**Purge Valve**  
Flow: 5 - 7 lt./min.

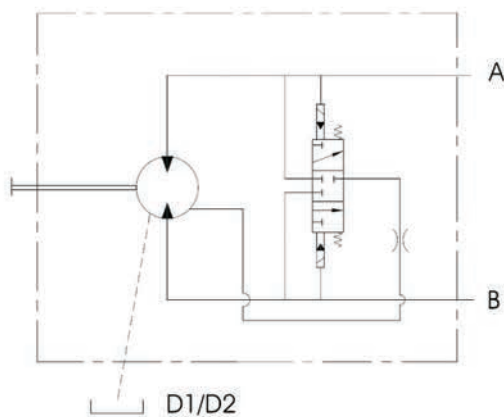

**METRIC Version**  
A – B: Pressure ports – 3/4" G  
D1 – D2: Drain ports – 1/2" G

**ACCESSORIES** (continued)  
**Pressure Relief Valve**

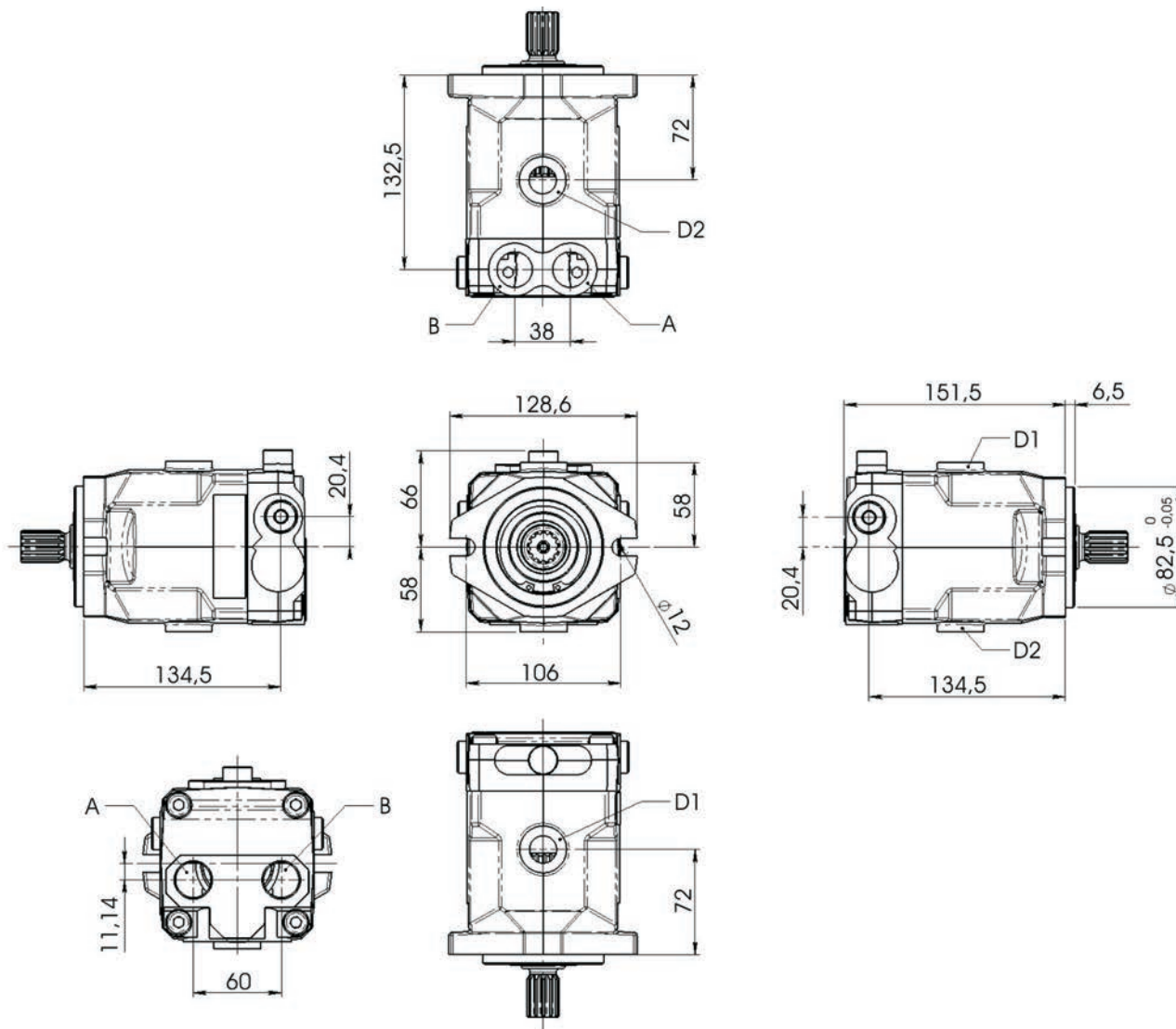

**METRIC Version**

A – B: Pressure ports – 3/4" G  
D1 – D2: Drain ports – 1/2" G

**ORDER CODE**

<b>TMF 300</b>	<b>21</b>	<b>1</b>	<b>B</b>	<b>1</b>	<b>T</b>	<b>P</b>	<b>-</b>
<b>1</b>	<b>2</b>	<b>3</b>	<b>4</b>	<b>2</b>	<b>6</b>	<b>7</b>	<b>8</b>

Pag.

**1 - Motor Series**

**TMF 300** = Fixed displacement motor TMF 300 Series

**2 - Motor Displacement**

**21** = 21 cm<sup>3</sup>/n

**28** = 28 cm<sup>3</sup>/n

**3 - Main Ports**

**1** = Rear A and B connection

**2** = Side combined A and B connection

**3** = Opposite side A and B connection

**4 - Rotation Direction**

**B** = Bidirectional (standard)

**5 - Shafts**

**1** = Parallel diam. 22,2 with key

**2** = Parallel diam. 25,4 with key

**5** = Splined male 13 teeth 16/32 DP

**6 - Port Version**

**T** = A and B ports thread - 3/4" BSPP

**7 - Optional** (omit if not requested)

**-** = Without optional

**P** = Rear drain

**V** = Purge valve

**8 - Special versions** (omit if not requested)

5

8

9

10







As HANSA-TMP has a very extensive range of products and some products have a variety of applications, the information supplied may often only apply to specific situations.

If the catalogue does not supply all the information required, please contact HANSA-TMP.

In order to provide a comprehensive reply to queries we may require specific data regarding the proposed application.

Whilst every reasonable endeavour has been made to ensure accuracy, this publication cannot be considered to represent part of any contract, whether expressed or implied.

HANSA-TMP reserves the right to amend specifications at their discretion.



**HYDRAULIC COMPONENTS**  
**HYDROSTATIC TRANSMISSIONS**  
**GEARBOXES - ACCESSORIES**

Via M. L. King, 6 - **41122 MODENA (ITALY)**  
Tel: +39 059 415 711  
Fax: +39 059 415 729 / 059 415 730  
INTERNET: <http://www.hansatmp.it>  
E-MAIL: [hansatmp@hansatmp.it](mailto:hansatmp@hansatmp.it)